

KNOT FLOER HOMOLOGY AND CATEGORIFICATION

Allison Leigh Gilmore

Submitted in partial fulfillment of the
requirements for the degree of
Doctor of Philosophy
in the Graduate School of Arts and Sciences

COLUMBIA UNIVERSITY

2011

©2011
Allison Leigh Gilmore
All rights reserved

ABSTRACT

Knot Floer Homology and Categorification

Allison Leigh Gilmore

With the goal of better understanding the connections between knot homology theories arising from categorification and from Heegaard Floer homology, we present a self-contained construction of knot Floer homology in the language of HOMFLY-PT homology. Using the cube of resolutions for knot Floer homology defined by Ozsváth and Szabó [45], we first give a purely algebraic proof of invariance that does not depend on Heegaard diagrams, holomorphic disks, or grid diagrams. Then, taking Khovanov’s HOMFLY-PT homology as our model, we define a category of twisted Soergel bimodules and construct a braid group action on the homotopy category of complexes of twisted Soergel bimodules. We prove that the category of twisted Soergel bimodules categorifies $H(b, q) \oplus \mathbb{Z}[\ell, \ell^{-1}]$, where $H(b, q)$ is the Hecke algebra. The braid group action, which is defined via twisted Rouquier complexes, is simultaneously a natural extension of the knot Floer cube of resolutions and a mild modification of the action by Rouquier complexes used by Khovanov in defining HOMFLY-PT homology [21]. Finally, we introduce an operation Qu to play the role that Hochschild homology plays in HOMFLY-PT homology. We conjecture that applying Qu to the twisted Rouquier complex associated to a braid produces the knot Floer cube of resolutions chain complex associated to its braid closure. We prove a partial result in this direction.

Contents

1	Introduction	1
2	The Knot Floer Cube of Resolutions	10
2.1	Definitions: Cube of resolutions for knot Floer homology	10
2.1.1	Algebra associated to a resolution	12
2.1.2	Differential	14
2.1.3	Gradings	14
2.1.4	Invariance	15
2.2	Non-local relations	15
2.3	Removing bivalent vertices	21
2.4	Braid-like Reidemeister move II	25
2.5	Conjugation: Moving the basepoint	28
2.6	Braid-like Reidemeister move III	31
2.7	Stabilization / Reidemeister move I	42
2.8	Identification with knot Floer homology	45
3	Braids, Soergel Bimodules, and Knot Floer Homology	50
3.1	Knot Floer cube of resolutions for braids	50
3.2	Soergel bimodules and HOMFLY-PT homology	55
3.3	Twisted Soergel bimodules	60
3.3.1	Overview	60
3.3.2	Definition and basic properties	61
3.3.3	The category \mathbf{SB}^τ	66
3.4	Twisted Rouquier complexes and a braid group action	69

4 Braid Closures and Ideal Quotients	74
4.1 The operation Qu	74
4.2 Background: Gröbner bases and Buchberger’s algorithm	78
4.2.1 Monomial orderings	78
4.2.2 Gröbner bases and the division algorithm	79
4.2.3 Buchberger’s algorithm and ideal quotients	80
4.2.4 Simplifying Gröbner basis computations	82
4.3 Buchberger’s algorithm: Preliminaries	84
4.4 Buchberger’s algorithm: Round 1	86
4.4.1 S-polynomials with $\nu z_\tau - z_\tau$	88
4.4.2 S-polynomials among subset relations	92
4.5 Buchberger’s algorithm: Round 2	95
4.5.1 Properties of $\nu z_\beta - z_\tau$ and their applications	95
4.5.2 More S-polynomials among subset relations	98
4.5.3 S-polynomials involving tilde relations	104
4.6 Buchberger’s algorithm: Round 3	111
4.6.1 S-polynomials with \bar{n}_Γ	114
Bibliography	119

ACKNOWLEDGMENTS

I am grateful to have had Peter Ozsváth as my thesis advisor. Besides having a never-ending supply of interesting problems to suggest, he has always been encouraging, supportive, and kind. Many thanks also to Robert Lipshitz for his patient guidance and excellent advice, especially during this last academic year. Mikhail Khovanov has also been very generous with his time and his ideas. I benefited enormously from the courses he taught at Columbia and from thought-provoking conversations in which he asked enough difficult questions to keep me busy for many years. Thank you also to my other committee members, Eli Grigsby and Josh Greene, for taking an interest in my work and for helpful conversations.

Daniel Krasner and Ben Elias were both excellent resources for my questions about Soergel bi-modules, HOMFLY-PT homology, and categorification generally. Ciprian Manolescu first mentioned the term ideal quotient to me and suggested its relevance to my project. John Baldwin made key suggestions when I was struggling with the proofs of Proposition 2.3.1 and the lemmas in Section 2.5. My thanks go to all of them.

I am grateful to the Mathematical Sciences Research Institute for hosting the special program on Homology Theories of Knots and Links that I attended in spring 2010, and to the participants of the program for many excellent conversations. The Simons Center for Geometry and Physics kindly hosted me as a visiting student in spring 2011. I appreciate their hospitality, their interesting seminars, and their delicious tea. Of course, the Columbia Mathematics Department has been my home for most of graduate school. Thank you to the staff, especially Terrance Cope, who can navigate any bureaucracy and solve any problem. Thank you also to my fellow students, especially the long list of people who have come through the Informal² HF Seminar while I have been at Columbia.

Thank you to Mike Lawler, who gave me a book on algebraic topology long before I could understand it and has been ready with great advice ever since.

I appreciate, as always, the love of my family and friends, especially my parents. They advocated for me, taught me to advocate for myself, found me every opportunity I could desire, and yet always helped me keep it all in perspective.

Finally, and most importantly, I cannot sufficiently thank Joe Ross. He has been my all-purpose math sounding board, my moral support, and my best friend. From my first week of graduate school to my last, from the late nights of problem sets in the library to the day of my defense, he has been there to reassure and to celebrate and always to love. May we have many more years together.

To my family

Chapter 1

Introduction

In the last decade, a powerful new type of knot invariant has emerged independently from two quite distinct areas of mathematics. To a knot K in S^3 , a knot homology theory associates a bigraded (or sometimes triply-graded) chain complex $C(K) = \bigoplus_{i,j} C_{ij}$ whose graded Euler characteristic is a classical knot polynomial

$$\chi_{\text{gr}}(C(K)) := \sum_{i,j} (-1)^i q^j \text{rk}(C_{ij}(K)) = p_K(q).$$

Knot Floer homology, developed by Ozsváth and Szabó [38] and Rasmussen [47], bears this relationship to the Alexander polynomial and has its heritage in gauge theory. Knot homologies for the Jones polynomial, the \mathfrak{sl}_n polynomials, and the HOMFLY-PT polynomial were inspired by work in representation theory and defined by Khovanov [18] and Khovanov and Rozansky [21, 22, 23].

Knot homologies have had a wide variety of applications in low-dimensional topology. Knot Floer homology has led to an improved understanding of the knot concordance group [37, 13], developments in Dehn surgery theory [41, 40, 43, 12], and new invariants of Legendrian and transverse knots [46, 32, 27]. It fits into a family of three- and four-manifold invariants called Heegaard Floer homology that have had even more far-reaching applications in low-dimensional topology, including invariants of contact structures on 3-manifolds [35] and of smooth 4-manifolds [44, 36], among many others. Applications of the Khovanov and Khovanov-Rozansky knot homologies include Rasmussen's definition of a concordance invariant [48], a bound on the Thurston-Bennequin number of a Legendrian knot [31], and a contact invariant [2].

Knot Floer homology was originally defined as a filtration on the chain complex of Heegaard Floer homology [39], a three-manifold invariant whose differentials count holomorphic disks in a symmetric product of a surface. Knots in this theory are represented by decorating a Heegaard diagram for a three-manifold, so invariance was proved by checking invariance under Heegaard moves. Knot

Floer homology also has a combinatorial construction, which represents knots using grid diagrams and interprets these grid diagrams as an especially convenient type of decorated Heegaard diagram in which holomorphic disks can be enumerated combinatorially [51, 33]. This construction was independently proved to be a knot invariant under an appropriate set of moves for grid diagrams [29].

The Khovanov and Khovanov-Rozansky knot homologies were originally defined using a fully algebraic “cube of resolutions” construction. Given a projection of a knot with m crossings, one considers two ways of resolving each crossing and arranges all possible resolutions into an m -dimensional cube. To each vertex of the cube, one associates a graded algebraic object (perhaps a graded vector space, or a graded module over some commutative ring), and to each edge of the cube a map. With the correct choices of objects and maps, the result is a chain complex whose graded Euler characteristic is the desired knot polynomial. Khovanov’s original link homology [18], whose graded Euler characteristic is the Jones polynomial, follows this model. It employs a cube in which the resolutions are the two possible smoothings of a crossing. A complete resolution is then a collection of circles, to which one associates certain graded vector spaces. Khovanov and Rozansky’s homology theories for the \mathfrak{sl}_n polynomials [22] and the HOMFLY-PT polynomial [23] (see also Khovanov [21] and Rasmussen [49]) instead use a cube of resolutions built from singularizations of crossings and oriented smoothings. The complete resolutions in this case are a particular type of oriented planar graph. The associated algebraic objects are graded modules over the ring $\mathbb{Q}[x_0, \dots, x_n]$, which has one indeterminate for each edge of the graph. In each of these theories, the chain complex was proved to be a knot invariant by directly checking invariance under Reidemeister moves. That is, one compares the prescribed chain complex before and after a Reidemeister move is performed on the diagram, and constructs a chain homotopy between the two complexes.

These algebraic knot homologies were motivated by the concept of categorification, which originally arose in representation theory. In the context of topology, categorification is a process of lifting algebraic invariants of topological objects to algebraic categories with richer structure, thereby enhancing the topological information they are able to encode. In this framework, knot polynomials should lift to complexes of modules; cobordisms should lift to maps of modules; and braid or tangle invariants should lift to complexes of bimodules. When one knot polynomial specializes to another, the corresponding homologies should be related by a spectral sequence. Such spectral sequences have been described among the knot homologies arising from representation theory: from HOMFLY-PT homology to each \mathfrak{sl}_n homology, including Khovanov’s original link homology [49].

The broad aim of this work is to understand better how knot Floer homology relates to the categorification knot homologies. Despite their disparate origins, all known knot homologies behave

similarly on certain classes of knots, give rise to similar (though ultimately distinct [15]) concordance invariants, and generalize classical knot polynomials in similar ways. The fact that the HOMFLY-PT polynomial specializes to the Alexander polynomial also strongly suggests that there should be a spectral sequence from HOMFLY-PT homology to knot Floer homology in analogy with the spectral sequences from HOMFLY-PT homology to the knot homologies of the Jones and \mathfrak{sl}_n polynomials [6, 49].

However, precise relationships between knot Floer homology and the Khovanov or Khovanov-Rozansky homologies have so far proved elusive. Ozsváth and Szabó [42] found a spectral sequence from a version of the Khovanov homology of a link to the Heegaard Floer homology of its branched double cover (see also [26]). This spectral sequence has since been generalized to a spectral sequence from a sutured variant of the Khovanov homology of a tangle in $D^2 \times I$ to the sutured Floer homology of its lift in the branched double cover $\Sigma(D^2 \times I)$ [14]. In certain cases, this sutured Floer homology can be interpreted as the knot Floer homology of the link's lift, but none of these spectral sequences converge directly to the knot Floer homology of the link itself (in S^3). These spectral sequences also depend strongly on the topology of the link's branched double cover. Moreover, these spectral sequences all begin with variants of the original Khovanov link homology (which categorifies the Jones polynomial). They are not the expected lifting of the relationship between the HOMFLY-PT polynomial and the Alexander polynomial obtained by specializing a variable. The problem of finding a direct relationship between the categorification knot homologies (especially the HOMFLY-PT homology) and knot Floer homology is the primary motivation for the work described here.

Therefore, our project is to interpret knot Floer homology in the context of categorification as thoroughly as possible. Ozsváth and Szabó took the first step in this direction by describing a cube of resolutions construction for knot Floer homology [45]. As in the constructions of \mathfrak{sl}_n and HOMFLY-PT homology, they use singularizations and oriented smoothings of crossings as the two possible resolutions, so that the complete resolutions are planar graphs with orientation and valency restrictions. In 2007, Ozsváth, Szabó and Stipsicz [34] described a version of knot Floer homology for singular knots that is related to the theory for classical knots by a skein exact sequence. In general, knot Floer homology for singular knots involves holomorphic disk counts, but it can be made combinatorial with a suitable choice of twisted coefficients and a particular Heegaard diagram. Using this version of the theory for singular knots and iterating the skein exact sequence allowed Ozsváth and Szabó [45] to construct a cube of resolutions chain complex that computes knot Floer homology.

Chapter 2 gives a direct proof of the invariance of knot Floer homology within the algebraic setting of the cube of resolutions chain complex, without relying on Heegaard diagrams, holomorphic

disks, or any of the usual geometric input. We use a small modification of the cube of resolutions construction described by Ozsváth and Szabó [45]. The construction begins with a projection of a knot as a closed braid, which we decorate with a basepoint and a number of extra bivalent vertices to create a *layered braid diagram* D . Each layer of the diagram contains a single crossing and a bivalent vertex on each strand not involved in the crossing. This amounts to choosing a braid word that represents the knot and subdividing some edges. We form a cube of resolutions by singularizing or smoothing each crossing of the projection. We then assign a graded algebra $\mathcal{A}_I(D)$ to each resolution and arrange these into a chain complex $C(D)$. These objects are defined precisely in (2.1) and (2.2) of Section 2.1. The resolutions to which $\mathcal{A}_I(D)$ is assigned are planar graphs with particular orientation conventions. The algebra $\mathcal{A}_I(D)$ is a quotient of a polynomial ring $\mathcal{E}(D)$ with one indeterminate for each edge in D by two ideals: an ideal $\mathcal{L}_I(D)$ generated by local relations depending only on edge data near each vertex in the I -resolution of D and an ideal $\mathcal{N}_I(D)$ generated by non-local relations depending on edge data from subsets of vertices. The main result of Chapter 2 is an algebraic proof of

Theorem (Theorem 2.1.1). *Let D be a layered braid diagram for a knot K . The chain complex $C(D)$, up to chain homotopy equivalence and base change, is invariant under the Markov moves and the addition or removal of layers with only bivalent vertices. Therefore, $H_*(C(D))$ depends only on the knot K .*

Theorem 2.1.1 holds with coefficients in \mathbb{Z} . It is stated in full detail in Section 2.1.4. Changing to \mathbb{F}_2 coefficients, we identify $H_*(C(D))$ with HFK^- and a reduced version of $C(D)$ with \widehat{HFK} in Section 2.8. We expect that $H_*(C(D))$ in fact computes knot Floer homology with integer coefficients, but do not pursue this point here.

The proof of invariance under braid-like Reidemeister moves II and III is very closely modeled on Khovanov and Rozansky's proof for HOMFLY-PT homology in [23]. Specifically, we prove categorified versions of the braid-like Murakami-Ohtsuki-Yamada (MOY) relations [30], specialized as appropriate for the Alexander polynomial. These relations arise in Murakami, Ohtsuki, and Yamada's [30] definition of a two-variable polynomial invariant of weighted singular tangles. Its weighted sum over the possible singularizations and smoothings of a knot gives the HOMFLY-PT polynomial. Khovanov and Rozansky's HOMFLY-PT homology [23] categorifies the MOY model for the HOMFLY-PT polynomial; the knot Floer cube of resolutions appears to categorify the same model, specialized for the Alexander polynomial. This observation, along with the expectation that HOMFLY-PT homology should be directly related to knot Floer homology via a spectral sequence, suggests that HOMFLY-PT homology would be the appropriate model for our interpretation of knot Floer homology in the context of categorification.

Chapters 3 and 4 undertake the project of building the knot Floer cube of resolutions from HOMFLY-PT homology’s algebraic materials. Khovanov’s construction of HOMFLY-PT homology via Soergel bimodules and Hochschild homology [21] turns out to be a more natural choice than the Khovanov-Rozansky construction via matrix factorizations [23], but the two approaches are equivalent in any case. HOMFLY-PT homology’s structure as a categorification differs somewhat from the usual blueprint described above, so we outline it briefly here, first introducing several relevant categories.

Let \mathbf{BrCob}_b denote the category whose objects are braid diagrams on b strands and whose morphisms are braid cobordisms up to isotopy. A braid cobordism between braids σ and σ' is a compact surface S smoothly embedded in $\mathbb{R}^2 \times [0, 1] \times [0, 1]$ with boundary conditions

$$\begin{aligned} S \cap (\mathbb{R}^2 \times [0, 1] \times \{0\}) &= \sigma, \\ S \cap (\mathbb{R}^2 \times [0, 1] \times \{1\}) &= \sigma', \\ S \cap (\mathbb{R}^2 \times \{0\} \times [0, 1]) &= \{1, 2, \dots, b\} \times \{0\} \times [0, 1] \text{ and} \\ S \cap (\mathbb{R}^2 \times \{1\} \times [0, 1]) &= \{1, 2, \dots, b\} \times \{1\} \times [0, 1]. \end{aligned}$$

Note that isotopic braids are isomorphic, but not equal, as objects of \mathbf{BrCob}_b .

Let \mathbf{SBrCob}_b denote the category of singular braids and their cobordisms. For our purposes, a singular braid will be any diagram that is obtained from a braid diagram by replacing each crossing with either its oriented resolution or with a double point. However, it is more convenient to use “webs” for the sake of defining cobordisms (although we draw 4-valent vertices throughout). A web is a planar weighted trivalent graph with certain incidence and orientation restrictions (see [20] or [28] for details). We restrict to those webs that arise from braids by replacing crossings with oriented resolutions or with wide edges as in Figure 1.1. The morphisms in \mathbf{SBrCob}_b will be “foams,” which are decorated 2-dimensional CW complexes embedded in \mathbb{R}^3 with appropriate boundary conditions to make them a singular analogue of tangle cobordisms [20, 28, 3].

Finally, for a unital, associative algebra R over a fixed field k (which will be \mathbb{Q} when not otherwise specified), let $R\text{-grbimod}$ denote the category whose objects are \mathbb{Z} -graded bimodules over R that are finitely generated as both left and right modules. A morphism of \mathbb{Z} -graded bimodules is a map that is simultaneously a left-module homomorphism and a right-module homomorphism and that preserves the grading. Let $\text{Com}(\mathcal{C})$ denote the homotopy category of bounded complexes of objects in the additive category \mathcal{C} . That is, the morphisms $\text{Hom}(M, N)$ are morphisms of complexes (chain maps) between M and N modulo homotopy equivalence.

Khovanov [21] first defined HOMFLY-PT homology via a braid group action on a certain subcategory of $\text{Com}(\mathbb{Q}[x_1, \dots, x_b]\text{-grbimod})$. The braid group action was later extended [25, 9] to



Figure 1.1: Braid-like diagrams using trivalent vertices and weighted edges (left) are the objects in the category \mathbf{SBrCob} . We draw them with 4-valent vertices (right) instead.

functors

$$\mathcal{F}_{\text{HOMFLY-PT}}^b : \mathbf{BrCob}_b \rightarrow \text{Com}(\mathbb{Q}[x_1, \dots, x_b]\text{-grbimod})$$

for each positive integer b . These are built from functors

$$\widehat{\mathcal{F}}_{\text{HOMFLY-PT}}^b : \mathbf{SBrCob}_b \rightarrow \mathbb{Q}[x_1, \dots, x_b]\text{-grbimod}$$

that assign to each singular braid a bimodule in a special class identified by Soergel [52, 53]. Soergel bimodules categorify the Hecke algebra

$$\begin{aligned} H(b, q) &= \langle g_1, \dots, g_{b-1} \mid g_i^2 = (q + q^{-1})g_i, \\ &\quad g_i g_{i+1} g_i + g_{i+1} = g_{i+1} g_i g_{i+1} + g_i, \\ &\quad g_i g_j = g_j g_i \text{ if } |i - j| > 1 \rangle. \end{aligned}$$

That is, there is an isomorphism of rings

$$\Phi : H(b, q) \longrightarrow K_0(\text{Kar}(\mathbf{SB}))$$

from the Hecke algebra to the split Grothendieck group of the Karoubi envelope of the category of Soergel bimodules. Section 3.2 describes this isomorphism and other properties of the Soergel bimodules category in more detail. The appearance of the Hecke algebra is no surprise: there is a trace on the Hecke algebra, defined by Ocneanu, that can be normalized to give the HOMFLY-PT polynomial [10, 16]. Functoriality of the assignment of Soergel bimodules to singular braids is still work in progress by Blanchet [3], but similar results are known to hold in \mathfrak{sl}_n homologies [28]. Finally, the braid invariants $\mathcal{F}_{\text{HOMFLY-PT}}^b$ become invariants of closed braids after the application of Hochschild homology.

We propose that knot Floer homology should also be related to Soergel bimodules and that it should have an interpretation as functors

$$\begin{aligned} \mathcal{F}_{\text{HFK}}^b : \mathbf{BrCob}_b &\rightarrow \text{Com}(S\text{-grbimod}) \text{ and} \\ \widehat{\mathcal{F}}_{\text{HFK}}^b : \mathbf{SBrCob}_b &\rightarrow S\text{-grbimod} \end{aligned}$$

for an appropriate choice of S and some collection of distinguished bimodules related to Soergel bimodules. There should also be an operation on complexes of bimodules that recovers knot Floer homology of a braid's closure from the value of $\mathcal{F}_{\text{HFk}}^b$ on the braid.

We achieve substantial parts of this proposed structure for knot Floer homology in Chapters 3 and 4. Chapter 3 concerns braids and Soergel bimodules while Chapter 4 considers a replacement for Hochschild homology that allows us to pass to closed braids. We begin the consideration of braid invariants in Section 3.1 with a naïve generalization of the knot Floer cube of resolutions to braids. Given a layered diagram D_σ for a braid $\sigma \in \text{Br}_b$, we form a cube of resolutions by singularizing or smoothing each crossing. We assign an algebra $\mathcal{A}_I(D_\sigma)$ to each resolution by the same method as for closed braids in Chapter 2. The algebra is a quotient of a polynomial ring $\mathcal{E}(D_\sigma)$ with one indeterminate for each edge of the diagram by an ideal of local relations $\mathcal{L}_I(D_\sigma)$ and an ideal of non-local relations $\mathcal{N}_I(D_\sigma)$. However, starting with a braid rather than its closure means that we distinguish between edges incident to the top boundary of the braid and edges incident to the bottom boundary. The polynomial ring $\mathcal{E}(D_\sigma)$ contains b additional variables compared to the corresponding polynomial ring for $D_{\hat{\sigma}}$, the braid closure of the diagram D_σ , and some relations in $\mathcal{L}_I(D_\sigma)$ and $\mathcal{N}_I(D_\sigma)$ differ from their counterparts in the algebra $\mathcal{A}_I(D_{\hat{\sigma}})$. These subtle differences make the ideal of non-local relations redundant. We prove in Proposition 3.1.1 that $\mathcal{N}_I(D_\sigma) \subset \mathcal{L}_I(D_\sigma)$ as ideals in $\mathcal{E}(D_\sigma)$. This is certainly not the case for $\mathcal{N}_I(D_{\hat{\sigma}})$ and $\mathcal{L}_I(D_{\hat{\sigma}})$ in $\mathcal{E}_I(D_{\hat{\sigma}})$.

Section 3.2 introduces the language of Soergel bimodules as used in HOMFLY-PT homology and provides the necessary background to understand Khovanov's construction in [21]. In Section 3.3, we define Soergel bimodules over a polynomial ring with an extra parameter, then generalize to a larger category of bimodules we call twisted Soergel bimodules. The generalization to twisted Soergel bimodules is designed to recapture the behavior of the naïve knot Floer braid invariant from Section 3.1, which we prove it does in Proposition 3.3.1. We also prove that our new category is only a mild generalization of the original Soergel bimodules category. In particular, twisted Soergel bimodules categorify the Hecke algebra with an additional indeterminate and its inverse adjoined.

Proposition (Proposition 3.3.5). *Let \mathbf{SB}^τ denote the category of twisted Soergel bimodules and $\text{Kar}(\mathbf{SB}^\tau)$ its Karoubi envelope. Let \mathbf{K}_0 denote the split Grothendieck group and $H(b, q)$ the Hecke algebra with $b - 1$ generators over $\mathbb{Z}[q^{-1}, q]$. Then there is a ring isomorphism*

$$\Phi^\tau : H(b, q) \otimes_{\mathbb{Z}} \mathbb{Z}[\ell, \ell^{-1}] \longrightarrow \mathbf{K}_0(\text{Kar}(\mathbf{SB}^\tau)).$$

We assign twisted Soergel bimodules to layered singular braid diagrams, which are singular braids with extra markings. We expect that this assignment would be functorial with respect to a suitably decorated type of foam, but do not pursue the issue here. Instead, by the same procedure used to

pass from $\widehat{\mathcal{F}}_{\text{HOMFLY-PT}}^b$ to $\mathcal{F}_{\text{HOMFLY-PT}}^b$, Section 3.4 defines a braid group action on the category of twisted Soergel bimodules. We expect that this braid group action could be extended to be functorial with respect to braid cobordisms, but do not pursue the issue here.

In Chapter 4, we attempt to pass from braids to closed braids and recover knot Floer homology from the braid invariant of Chapter 3. The idea is to define an operation Qu that converts the twisted Soergel bimodule associated to a layered singular braid to the algebra \mathcal{A}_I associated to its braid closure in Chapter 2. The operation Qu takes the place of Hochschild homology, which is the operation used to pass from braids to their closures in HOMFLY-PT homology. It is defined as a quotient of the zeroth Hochschild homology. We do not yet have a full understanding of how the operation Qu relates to Hochschild homology, or whether it could instead be defined in relation to the full Hochschild complex, but it is clear that Hochschild homology itself is not the appropriate operation to recover knot Floer homology. One reason is that Hochschild homology would add an additional grading to the theory, which would be unexpected in the knot Floer case. Perhaps more importantly, small examples demonstrate that Hochschild homology of Soergel bimodules simply does not produce the knot Floer algebra for a closed singular braid.

Applying the operation Qu to each homological grading of the chain complex associated to a layered braid in Chapter 3 produces a bigraded chain complex that is an invariant of the layered braid's closure. We conjecture that this chain complex is the cube of resolutions chain complex from Chapter 2 under the edge-strand correspondence, which is an isomorphism described in Equation 3.2 that converts between twisted Soergel bimodules and the naïve knot Floer braid invariant.

Conjecture (Conjecture 4.1.1). *Let σ be a braid, D_σ a layered braid diagram, and $D_{\widehat{\sigma}}$ a layered braid diagram for its closure. Let $B_I^{\tau}(D_\sigma)$ be the twisted Soergel bimodule associated to the I -resolution of D_σ in Chapter 3. Let $\mathcal{A}_I(D_{\widehat{\sigma}})$ be the algebra associated to the I -resolution of $D_{\widehat{\sigma}}$ in the knot Floer cube of resolutions of Chapter 2, defined over $\widehat{\mathcal{R}} = \mathbb{Z}[t^{-1}, t]$. Then*

$$\text{Qu}(B_I^{\tau}(D_\sigma)) \cong \mathcal{A}_I(D_{\widehat{\sigma}}) \otimes_{\mathbb{Z}} \mathbb{Q}. \quad (1.1)$$

For now, we prove a weaker result, passing to a simpler ground ring and putting aside some of the local relations in the definitions of $\mathcal{A}_I(D_\sigma)$ and $\mathcal{A}_I(D_{\widehat{\sigma}})$. Let $\mathcal{E}'(D_\sigma)$ and $\mathcal{E}'(D_{\widehat{\sigma}})$ be polynomial rings over \mathbb{Q} with one indeterminate for each edge in D_σ or $D_{\widehat{\sigma}}$ respectively. These differ from $\mathcal{E}(D_\sigma)$ in Chapter 3 and $\mathcal{E}(D_{\widehat{\sigma}})$ in Chapter 2 only because they are defined over a different ground ring. Define $\mathcal{L}'_I(D_\sigma)$ and $\mathcal{L}'_I(D_{\widehat{\sigma}})$ to be the ideals of $\mathcal{E}'(D_\sigma)$ and $\mathcal{E}'(D_{\widehat{\sigma}})$ obtained by removing the extra parameter t in the definition of the generating sets of $\mathcal{L}_I(D_\sigma)$ and $\mathcal{L}_I(D_{\widehat{\sigma}})$. Similarly, define modified ideals of non-local relations $\mathcal{N}'_I(D_\sigma)$ and $\mathcal{N}'_I(D_{\widehat{\sigma}})$. Finally, let $\mathcal{Q}'_I(D_\sigma) \subset \mathcal{L}'_I(D_\sigma)$ and $\mathcal{Q}'_I(D_{\widehat{\sigma}}) \subset \mathcal{L}'_I(D_{\widehat{\sigma}})$ denote the ideals generated by the linear relations associated to bivalent vertices

and the quadratic relations associated to 4-valent vertices. Then we prove the following theorem in Chapter 4.

Theorem (Theorem 4.1.1). *Let σ be a braid, D_σ a layered braid diagram, and $D_{\hat{\sigma}}$ a layered braid diagram for its closure. Then*

$$\text{Qu} \left(\frac{\mathcal{E}'(D_\sigma)}{\mathcal{Q}'_I(D_\sigma) + \mathcal{N}'_I(D_\sigma)} \right) \cong \frac{\mathcal{E}'_I(D_{\hat{\sigma}})}{\mathcal{Q}'_I(D_{\hat{\sigma}}) + \mathcal{N}'_I(D_{\hat{\sigma}})}$$

The proof of Theorem 4.1.1 is algorithmic, making use of convenient generating sets for ideals called Gröbner bases that are widely used in computational commutative algebra and algebraic geometry.

In future work, we plan to study the operation Qu in more detail, especially in relation to Hochschild homology and related functors on bimodules. It would also be interesting to know how Qu decategorifies, and specifically whether there is a representation theoretic description of this operation that connects a categorification of the Hecke algebra to a categorification of the Alexander polynomial. Finally, we hope that our approach to understanding knot Floer homology in the language of HOMFLY-PT homology will provide insight into the problem of finding a spectral sequence from HOMFLY-PT homology to knot Floer homology.

Chapter 2

The Knot Floer Cube of Resolutions

This chapter introduces the cube of resolutions construction of knot Floer homology and uses it to give an algebraic proof that knot Floer homology is a knot invariant. Section 2.1 describes the modified construction of Ozsváth and Szabó's [45] cube of resolutions that we will use throughout our work. Section 2.2 examines in detail the non-local relations involved in the definition of the algebra associated to a resolution. These relations are a key difference between the cube of resolutions theories for knot Floer homology and HOMFLY-PT homology. Section 2.3 establishes a technical proposition allowing us to remove sets of bivalent vertices under certain conditions. The next sections address each of the Markov moves in turn. Section 2.8 verifies that the cube of resolutions defined here computes knot Floer homology.

2.1 Definitions: Cube of resolutions for knot Floer homology

We begin with an oriented braid-form projection D of an oriented knot K in S^3 . Let b refer to the number of strands in D (which is not necessarily the braid index of K). Subdivide one of the outermost edges of D by a basepoint $*$. Isotoping D as necessary, fix an ordering on its crossings so that D is the closure of a braid diagram that is a stack of $m + 1$ horizontal layers, each containing a single crossing and $b - 2$ vertical strands. Label the horizontal layers s_0, \dots, s_m . This amounts to choosing a braid word for D . In each horizontal layer, add a bivalent vertex to each strand that is not part of the crossing. Finally, label the edges of D by $0, \dots, n$ such that 0 is the edge coming out from the basepoint and n is the edge pointing into the basepoint. A braid diagram in this form will

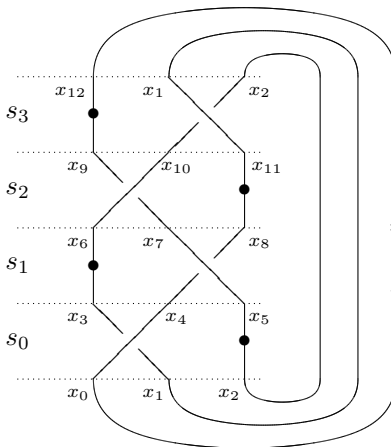

Figure 2.1: A layered braid diagram for the figure 8 knot.

be called a *layered braid diagram* for K . See Figure 2.1 for an example of a layered braid diagram of the figure 8 knot. Although Ozsváth and Szabó [45] use closed braid diagrams with basepoints in their definition of the knot Floer cube of resolutions, they do not require diagrams to be layered. This refinement appears to be critical to our proof of Proposition 2.3.1 and necessary for the proof of Reidemeister III invariance as well.

Each crossing in a knot projection can be singularized or smoothed. To singularize the crossing in layer s_i , replace it by a 4-valent vertex and retain all edge labels. To smooth the crossing in layer s_i , replace it with two vertical strands with one bivalent vertex on each, and retain all edge labels. Figure 2.2 illustrates these labeling conventions.

A resolution of a knot projection is a diagram in which each crossing has been singularized or smoothed. Alternatively, it is a planar graph in which each vertex is either (1) 4-valent with orientations as in Figure 2.2, or (2) bivalent with one incident edge oriented towards the vertex and the other oriented away from the vertex. For a positive crossing, declare the singularization to be the 0-resolution and the smoothing to be the 1-resolution. For a negative crossing, reverse these labels. A resolution of a knot projection can then be specified by a multi-index of 0s and 1s, generically denoted $\epsilon_0 \dots \epsilon_m$, or simply I , which we will think of as a vertex of a hypercube. Considering all possible singularizations and smoothings of all crossings, we obtain a cube of resolutions for the original knot projection. The homological grading on the cube will be given by collapsing diagonally; that is, by summing $\epsilon_0 + \dots + \epsilon_m$.

Let $\mathcal{R} = \mathbb{Z}[t^{-1}, t]$ and $\underline{x}(D)$ denote a set of formal variables x_0, \dots, x_n corresponding to the edges

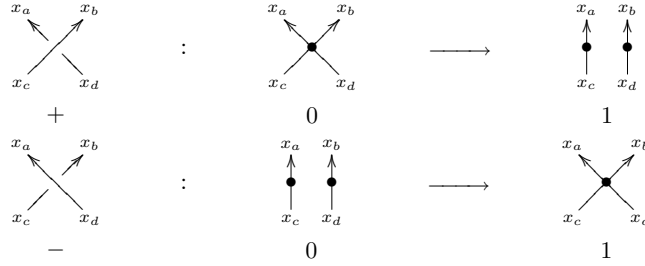

Figure 2.2: Notation for the singularization and smoothing of a positive (respectively negative) crossing.

of D . Define the *edge ring* of D to be $\mathcal{R}[\underline{x}(D)]$, which we will abbreviate to $\mathcal{R}[\underline{x}]$ if D is clear from context. To each vertex of the cube of resolutions, we will associate an \mathcal{R} -algebra $\mathcal{A}_I(D)$, which is a quotient of the edge ring by an ideal defined by combinatorial data in the I -resolution of D . To each edge of the cube, we will associate a map. Together with proper choices of gradings, these data define a chain complex of graded algebras over $\mathcal{R}[\underline{x}(D)]$. We will sometimes need to complete \mathcal{R} or $\mathcal{R}[\underline{x}(D)]$ with respect to t , meaning that we will allow Laurent series in t with coefficients in \mathbb{Z} or $\mathbb{Z}[\underline{x}(D)]$, respectively. Denote these completions $\widehat{\mathcal{R}}$ and $\widehat{\mathcal{R}[\underline{x}(D)]}$, respectively. More specifically, the proof of invariance under stabilization requires extending the base ring to $\widehat{\mathcal{R}[\underline{x}(D)]}$ and the identification of the homology of $C(D)$ with knot Floer homology requires extending to $\widehat{\mathcal{R}[\underline{x}(D)]}$ (as well as passing to \mathbb{F}_2 coefficients) to bring our construction in line with that of Ozvath and Szabo [45].

2.1.1 Algebra associated to a resolution

The algebra associated to the I -resolution of the knot projection D , which we will denote $\mathcal{A}_I(D)$, is the quotient of the edge ring by the ideal generated by the following three types of relations.

1. Linear relations associated to each vertex.

$$t(x_a + x_b) - (x_c + x_d) \quad \text{to} \quad \begin{array}{c} x_a \quad x_b \\ \diagdown \quad \diagup \\ \bullet \\ \diagup \quad \diagdown \\ x_c \quad x_d \end{array}$$

$$tx_{i+1} - x_i \quad \text{to} \quad \begin{array}{c} \uparrow x_{i+1} \\ \bullet \\ \downarrow x_i \end{array}$$

2. Quadratic relations associated to each 4-valent vertex.

$$t^2x_ax_b - x_cx_d \quad \text{to} \quad \begin{array}{c} x_a \quad x_b \\ \diagdown \quad \diagup \\ \bullet \\ \diagup \quad \diagdown \\ x_c \quad x_d \end{array}$$

Note that this relation can always be rewritten in four different ways by combining with the linear relation corresponding to the same vertex:

$$\begin{aligned} (tx_a - x_c)(x_d - tx_a) & \quad \text{or} \quad (tx_b - x_c)(x_d - tx_b) & \quad \text{or} \\ (tx_a - x_c)(tx_b - x_c) & \quad \text{or} \quad (tx_a - x_d)(tx_b - x_d). \end{aligned}$$

3. Non-local relations associated to sets of vertices in the resolved diagram. These have several equivalent definitions, which will be explored in detail in Section 2.2. Denote the ideal generated by non-local relations in I -resolution of D by $\mathcal{N}_I(D)$ or simply \mathcal{N}_I .

We refer to the linear and quadratic relations as the local relations. Let \mathcal{L} denote the ideal they generate together, and \mathcal{L}_i denote the ideal generated by the local relations in layer s_i . Then we have defined the algebras that belong at the corners of the cube of resolutions as

$$\mathcal{A}_I(D) = \frac{\mathcal{R}[x_0, \dots, x_n]}{\mathcal{L} + \mathcal{N}_I}. \quad (2.1)$$

Throughout this paper, we will use “ \equiv ” to indicate that two polynomials in the edge ring are equivalent up to multiplication by units in $\mathcal{R}[\underline{x}(D)]/\mathcal{L}$. Such polynomials are equivalent in the sense that they generate the same ideal in $\mathcal{R}[\underline{x}(D)]/\mathcal{L}$. We will represent generating sets for ideals as single-column matrices. The entries of the matrices are elements of the edge ring. The matrices can be manipulated using row operations without changing the ideal they generate because the ideal (a, b) is identical to the ideal $(a, b + sa)$ for any unit $s \in \mathcal{R}$ and $a, b \in \mathcal{R}[\underline{x}(D)]$. Also, when we see a row of the form $a - b$ in a matrix, we can replace b by a in all other rows and eliminate b from the edge ring. This will not change the quotient of the edge ring by the ideal of relations. Although the matrix manipulations in the following sections look very similar to those in [23] and [49], the matrices here do not formally represent matrix factorizations.

The algebra $\mathcal{A}_I(D)$ is a twisted version of the singular knot Floer homology of the I -resolution of D treated as a singular knot with bivalent vertices. Reverting to \mathbb{F}_2 coefficients and setting $x_a = x_b$ at each 4-valent vertex and x_0 to zero, then taking homology, gives the theory called HFS in [34]. Setting all of the edge variables to zero before taking homology gives the theory called \widetilde{HFS} in [34]. Both HFS and \widetilde{HFS} categorify the singular Alexander polynomial (or a multiple thereof). However, HFS is completely determined by the singular Alexander polynomial, while \widetilde{HFS} contains additional information.

2.1.2 Differential

An edge of the cube of resolutions goes between two resolutions that differ at exactly one crossing. To an edge that changes the i^{th} crossing, we associate a map $\mathcal{A}_{\epsilon_0 \dots 0 \dots \epsilon_m}(D) \rightarrow \mathcal{A}_{\epsilon_0 \dots 1 \dots \epsilon_m}(D)$. If s_i was positive in the original knot projection, then the edge goes from a diagram containing the singularization of s_i to a diagram containing its smoothing. The ideal of relations associated to the singularized crossing is contained in the ideal of relations associated to the resolved crossing, so $\mathcal{A}_{\epsilon_0 \dots 1 \dots \epsilon_m}(D)$ is a quotient of $\mathcal{A}_{\epsilon_0 \dots 0 \dots \epsilon_m}(D)$. The corresponding map in this case will be the quotient map. If s_i was negative in the original knot projection, then the edge goes from the smoothing to the singularization of s_i . The corresponding map in this case will be multiplication by $tx_a - x_d$, or equivalently by $tx_b - x_c$, where the crossing s_i is labeled as in Figure 2.2.

We have now assembled all of the pieces needed to define the chain complex $(C(D), d)$ that will compute knot Floer homology. Let

$$C(D) = \bigoplus_{I \in \{0,1\}^{m+1}} \mathcal{A}_I(D) \quad (2.2)$$

with total differential d the sum of all edge maps and homological grading given by $\epsilon_0 + \dots + \epsilon_m$. This is the chain complex that computes $HF\widehat{K}^-$ (see Proposition 2.8.1). There is also a reduced version of this chain complex obtained by setting x_0 to zero in each $\mathcal{A}_I(D)$. Its homology computes $\widehat{HF\widehat{K}}$.

2.1.3 Gradings

The chain complex $C(D)$ comes equipped with an additional grading called the Alexander grading. Let \mathcal{R} be in grading 0 and each edge variable x_i in grading -1. The relations used to form $\mathcal{A}_I(D)$ are homogeneous with respect to this grading, so it descends from the edge ring to a grading on $\mathcal{A}_I(D)$ (called A_0 in [45]). To symmetrize, adjust upwards by a factor of $\frac{1}{2}(\sigma - b + 1)$, where σ is the number of singular points in the I -resolution of D and b is the number of strands in D . Call this the internal grading, A_I , on $\mathcal{A}_I(D)$.

The Alexander grading on $\mathcal{A}_I(D)$ as a summand of the cube $C(D)$ is further adjusted from the internal grading by

$$A = A_I + \frac{1}{2} \left(-N + \sum_{i=0}^m \epsilon_i \right),$$

where $\epsilon_0, \dots, \epsilon_m$ are the components of the multi-index I and N is the number of negative crossings in D . This grading A is the final Alexander grading on the complex $C(D)$.

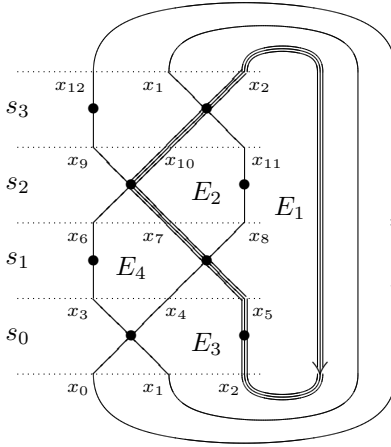

Figure 2.3: Singularization of the minimal braid presentation of the figure 8 knot with edges labeled x_0, \dots, x_{12} and orientations consistent with those in Figure 2.1. The bold line shows a cycle whose corresponding non-local relation is $t^8 x_1 x_9 - x_4 x_6$. Elementary regions are labeled E_1, \dots, E_4 . The coherent region $E_1 \cup E_2$ produces the same non-local relation as the cycle in bold, as does the subset consisting of the bivalent vertex in s_0 , the 4-valent vertex in s_1 , all vertices in s_2 , and the 4-valent vertex in s_3 .

2.1.4 Invariance

With these definitions in place, we may now state the invariance theorem precisely.

Theorem 2.1.1. *Let D be a layered braid diagram with initial edge x_0 representing a knot K in S^3 . As a complex of graded $\widehat{\mathcal{R}}[x_0]$ -modules up to chain homotopy equivalence and base change, $C(D) \otimes_{\mathcal{R}} \widehat{\mathcal{R}}$ is invariant under Markov moves on D and the addition or removal of layers containing only bivalent vertices. Therefore, $H_*(C(D)) \otimes_{\mathcal{R}} \widehat{\mathcal{R}}$ is an invariant of the knot K .*

Note that the last statement relies on the flatness of $\widehat{\mathcal{R}}$ as an \mathcal{R} -module.

2.2 Non-local relations

We collect here three equivalent definitions of the non-local relations used in the description of the algebra $\mathcal{A}_I(D)$, along with several straightforward observations that will nonetheless be very useful in later arguments. Figure 2.3 will serve as a source of examples throughout.

First, we may generate \mathcal{N}_I by associating a relation to each cycle (closed path) in the resolved diagram that does not pass through the basepoint and that is oriented consistently with D .

Definition 2.2.1 (Cycles). *Let Z be a closed path in the I -resolution of D that does not pass through the basepoint and is oriented consistently with D . Let R_Z be the region it bounds in the plane, containing the braid axis. The weight $\mathbf{w}(Z)$ of Z is twice the number of 4-valent vertices plus the number of bivalent vertices in the closure of R_Z . The non-local relation associated to Z is*

$$t^{\mathbf{w}(Z)} w_{out} - w_{in},$$

where w_{out} (respectively w_{in}) is the product of the edges incident to exactly one vertex of Z that lie outside of R_Z and that point out of (respectively into) the region.

Figure 2.3 shows a cycle in the singularized figure 8 knot with associated relation $t^8 x_1 x_9 - x_4 x_6$.

A slightly different definition derives a generating set for \mathcal{N}_I from certain regions in the complement of the I -resolution of D . First define the *elementary regions* in the I -resolution of D to be the connected components of its complement in the plane, except for the two components that are adjacent to the basepoint. For example, there are four elementary regions in the singularized figure 8 shown in Figure 2.3.

Since D is assumed to be in braid position, the elementary regions can be partially ordered based on which two strands of D they lie between. Label the strands of D from 1 (innermost, nearest the braid axis) to b (outermost, nearest the non-compact region). Then $E_i < E_j$ with respect to the partial order if E_i is closer to the braid axis than E_j ; that is, if E_i lies between lower-numbered strands than E_j does. Let E_1 denote the innermost elementary region, containing the braid axis. Label the other elementary regions E_2, \dots, E_m so that whenever $i < j$, E_i is less than or not comparable to E_j with respect to the partial order.

Definition 2.2.2 (Coherent Regions). *A coherent region in the I -resolution of D is the union of a set of non-comparable elementary regions, along with all elementary regions less than these under the partial order described above. The weight $\mathbf{w}(R)$ of a coherent region R is twice the number of 4-valent vertices plus the number of bivalent vertices in the closure of R . The non-local relation associated to R is*

$$t^{\mathbf{w}(R)} w_{out} - w_{in},$$

where w_{out} (respectively w_{in}) is the product of the edges outside R , but incident to exactly one vertex of ∂R and pointing out from (respectively into) R .

There are five coherent regions in the singularized figure 8 example of Figure 2.3, with associated relations as follows. Notice that, for example, $E_1 \cup E_2 \cup E_4$ is not a coherent region because $E_3 < E_4$.

coherent region	non-local relation
E_1	$t^6 x_1 x_7 - x_4 x_{10}$
$E_1 \cup E_2$	$t^8 x_1 x_9 - x_4 x_6$
$E_1 \cup E_3$	$t^8 x_3 x_7 - x_0 x_{10}$
$E_1 \cup E_2 \cup E_3$	$t^{10} x_3 x_9 - x_0 x_6$
$E_1 \cup E_2 \cup E_3 \cup E_4$	$t^{11} x_9 - x_0$

Finally, we may think of non-local relations as arising from subsets of vertices in the I -resolution of D .

Definition 2.2.3 (Subsets). *Let V be a subset of the vertices in the I -resolution of D . The weight $\mathbf{w}(V)$ of V is twice the number of 4-valent vertices plus the number of bivalent vertices in V . The non-local relation associated to V is*

$$t^{\mathbf{w}(V)} w_{out} - w_{in},$$

where w_{out} is the product of edges from V to its complement and w_{in} is the product of edges into V from its complement.

Any of these three definitions gives a generating set for $\mathcal{N}_I(D)$. We will prove that the three definitions are equivalent in Proposition 2.2.1. First, we record some observations about the efficiency of the generating sets prescribed by the different definitions.

A priori, the generating set obtained from subsets is much larger than those obtained from cycles or coherent regions. However, it actually suffices to consider a smaller collection of subsets whose associated relations still generate the same ideal in $\mathcal{R}[x_0, \dots, x_n]/\mathcal{L}$. First, we may restrict to connected subsets of vertices, meaning those whose union with their incident edges is a connected graph. If a subset V is disconnected as $V = V' \amalg V''$, then the outgoing (respectively incoming) edges from V are exactly the union of the outgoing (respectively incoming) edges from V' and V'' . Therefore, the non-local relation associated to V has the form

$$t^{\mathbf{w}(V')+\mathbf{w}(V'')} w'_{out} w''_{out} - w'_{in} w''_{in}.$$

However, this is already contained in the ideal generated by

$$t^{\mathbf{w}(V')} w'_{out} - w'_{in} \quad \text{and} \quad t^{\mathbf{w}(V'')} w''_{out} - w''_{in},$$

which are the non-local relations associated to V' and V'' .

Second, we may ignore a subset V if the union of V with its incident edges is a graph with no oriented cycles. In Figure 2.3, the two vertices in layer s_0 along with the 4-valent vertex in layer s_1 form such a subset. The non-local relation associated to this subset is $t^5 x_3 x_7 x_8 - x_0 x_1 x_2$, but simple substitutions using the local relations associated to the three vertices in the subset show that this supposedly non-local relation is actually contained in \mathcal{L} .

Observation 2.2.1. *The ideal of non-local relations \mathcal{N}_I can be generated by the non-local relations associated to connected subsets that contain oriented cycles.*

We prove this statement inductively, noting as a base case that the non-local relation associated to a subset with a single vertex is identical to the local relation associated to that vertex. Suppose V is a connected subset with no oriented cycles, that v is a bivalent vertex, and that $V \cup \{v\}$ is a connected subset with no oriented cycles. Then the non-local relation associated to $V \cup \{v\}$ is already contained in the ideal sum of \mathcal{L} with the non-local relation associated to V . Suppose that x_{out} is the edge from V to v and x_v is the edge pointing out from v . If $t^{\mathbf{w}(V)} w_{\text{out}} x_{\text{out}} - w_{\text{in}}$ is the non-local relation associated to V , then the relation associated to $V \cup \{v\}$ is $t^{\mathbf{w}(V)+1} w_{\text{out}} x_v - w_{\text{in}}$. Using the local relation $t x_v - x_{\text{out}}$ to replace x_v recovers the non-local relation associated to V . A similar argument applies if the edge between V and $\{v\}$ is oriented in the opposite direction.

Suppose instead that v is a 4-valent vertex with edges x_a and x_b pointing out and edges x_c and x_{out} pointing in. Suppose that x_{out} connects to a vertex $v' \in V$ and that none of x_a, x_b, x_c are incident to any vertex in V . The local relation associated to v is then $t^2 x_a x_b - x_c x_{\text{out}}$, while the non-local relation associated to V is of the form $t^{\mathbf{w}(V)} w_{\text{out}} x_{\text{out}} - w_{\text{in}}$. The non-local relation associated to $V \cup \{v\}$ is

$$t^{\mathbf{w}(V)+2} w_{\text{out}} x_a x_b - w_{\text{in}} x_c \equiv t^{\mathbf{w}(V)} w_{\text{out}} x_c x_{\text{out}} - w_{\text{in}} x_c = x_c (t^{\mathbf{w}(V)} w_{\text{out}} x_{\text{out}} - w_{\text{in}}).$$

Therefore, extending a connected graph with no oriented cycles by an adjacent 4-valent vertex produces a non-local relation already contained in the ideal sum of \mathcal{L} with the non-local relation associated to V .

The second observation of this section concerns redundancy in the generating sets for \mathcal{N}_I defined by cycles and coherent regions arising from certain elementary regions that can be removed from a coherent region without producing an independent non-local relation. For instance, in Figure 2.3, the coherent region $E_1 \cup E_2 \cup E_3 \cup E_4$ specifies the non-local relation $t^{11} x_9 - x_0$ as a generator for \mathcal{N}_I . Then $x_6 (t^{11} x_9 - x_0)$ is also in \mathcal{N}_I . It can be modified to $t^{10} x_3 x_9 - x_0 x_6$ using the relation $t x_6 - x_3$, which is the linear relation associated to the bivalent vertex in layer s_1 . We have obtained the non-local relation associated to $E_1 \cup E_2 \cup E_3$, showing that it is redundant once the non-local

relation for $E_1 \cup E_2 \cup E_3 \cup E_4$ is included in the generating set of \mathcal{N}_I . More formally, we have the following observation.

Observation 2.2.2. *Suppose a coherent region R has an adjacent elementary region E and that $\partial E \setminus \partial R \cap \partial E$ is a path of edges through bivalent vertices only. Then the non-local relation associated to R is contained in the ideal sum of \mathcal{L} with the non-local relation associated to $R \cup E$.*

Label the edges in the path in $\partial E \setminus \partial R \cap \partial E$ by $x_{\text{out}}, x_1, \dots, x_p, x_{\text{in}}$ consistent with the orientation of the overall diagram. The linear relations associated to each vertex in this path are $tx_1 - x_{\text{out}}$, $tx_{\text{in}} - x_p$, and $tx_{i+1} - x_i$ for $1 \leq i \leq p-1$. The non-local relation associated to R has the form

$$t^{\mathbf{w}}(R)w_{\text{out}}x_{\text{out}} - w_{\text{in}}x_{\text{in}},$$

which can be rewritten using the linear relations above to give

$$t^{\mathbf{w}(R)+p+1}w_{\text{out}}x_{\text{in}} - w_{\text{in}}x_{\text{in}} = \left(t^{\mathbf{w}(R)+p+1}w_{\text{out}} - w_{\text{in}} \right) x_{\text{in}},$$

which is a multiple of the non-local relation associated to $R \cup E$. Therefore, to form a minimal generating set for \mathcal{N}_I , we need only consider $R \cup E$.

As these observations begin to indicate, the definitions of non-local relations via cycles, coherent regions, and subsets are equivalent. In the example of Figure 2.3, the cycle shown in bold produces the same non-local relation as the coherent region $E_1 \cup E_2$ or the subset of vertices contained in $E_1 \cup E_2$. These correspondences between cycles, coherent regions, and subsets hold in general.

Proposition 2.2.1. *Definitions 2.2.1, 2.2.2, and 2.2.3 produce the same ideal in $\mathcal{R}[x_0, \dots, x_n]/\mathcal{L}$, where \mathcal{L} is the ideal generated by local relations associated to each vertex in the I -resolution of D .*

Proof. The equivalence between definitions 2.2.1 (cycles) and 2.2.2 (coherent regions) is clear: the boundaries of coherent regions are exactly the cycles that avoid the basepoint and have orientations matching that of D . (Consider, for example, the boundary of $E_1 \cup E_2 \cup E_3$ compared to that of $E_1 \cup E_2 \cup E_4$ in Figure 2.3.) Weights and the edge products w_{out} and w_{in} are identical for a coherent region R and the cycle ∂R , so the associated non-local relations are the same.

Let \mathcal{N} denote the ideal generated by non-local relations associated to cycles or coherent regions in $\mathcal{R}[\underline{x}(D)]/\mathcal{L}$. Let \mathcal{N}_S denote the ideal generated by non-local relations associated to subsets. Suppose R is a coherent region and V_R the set of vertices in its closure. Then $\mathbf{w}(R) = \mathbf{w}(V_R) = \mathbf{w}(\partial R)$ and the words w_{out} and w_{in} defined with respect to R , ∂R , or V_R are the same. Therefore, we have the inclusion $\mathcal{N} \subset \mathcal{N}_S$.

For the opposite inclusion, consider a subset V . We appeal first to Observation 2.2.1, which allows us to assume that the union of V and its incident edges forms a connected graph containing

an oriented cycle Z . Assume that Z is the outermost cycle contained in V , and let R_Z be the coherent region it bounds. If V contains all of the vertices in the closure of R_Z , then the arguments about connectedness and subsets just after Observation 2.2.1 allow us to remove all vertices from V that are not contained in the closure of R_Z , thereby showing that the non-local relation associated to V can be constructed from the non-local relation associated to R_Z .

Suppose now that V does not contain all of the vertices in R_Z . Then the complement of V is disconnected, with one component inside Z and one component outside. Denote these components V' and V'' , respectively. Then $V \cup V'$ contains Z and all of the vertices in the closure of R_Z , so the argument above shows that its associated non-local relation is contained in \mathcal{N} . The subset V' may not contain any oriented cycles or it may contain an oriented cycle Z' and all vertices in the closure of $R_{Z'}$. Therefore, its associated non-local relation is contained in either \mathcal{L} or \mathcal{N} .

Finally, we show that the non-local relation associated to V is in the ideal generated by the non-local relations associated to V' and $V \cup V'$. The words w_{out} and w_{in} defined with respect to V are products $w_{\text{out}} = w'_{\text{in}} w''_{\text{in}}$ and $w_{\text{in}} = w'_{\text{out}} w''_{\text{out}}$ of edges into and out from V' and V'' .

$$\begin{aligned}
& t^{\mathbf{w}(V)} w'_{\text{in}} w''_{\text{in}} - w'_{\text{out}} w''_{\text{out}} && \text{non-local relation from } V \\
\equiv & t^{\mathbf{w}(V) + \mathbf{w}(V')} w'_{\text{out}} w''_{\text{in}} - w'_{\text{out}} w''_{\text{out}} && \text{by substituting non-local relation from } V' \\
= & (t^{\mathbf{w}(V) + \mathbf{w}(V')} w''_{\text{in}} - w''_{\text{out}}) w'_{\text{out}} && \text{a multiple of the non-local relation } V \cup V'
\end{aligned}$$

Since the non-local relation associated to V can be constructed from those associated to V' and $V \cup V'$, it is contained in \mathcal{N} . Therefore, any non-local relation associated to a subset can be generated from non-local relations associated to coherent regions, meaning that $\mathcal{N}_S \subset \mathcal{N}$. \square

Two further observations related to the non-local relations are worth recording for later use.

Observation 2.2.3. *The relation $t^{\mathbf{w}(D)} x_n - x_0$, where x_n is the edge entering the basepoint and x_0 is the edge leaving it, holds in $\mathcal{A}_I(D)$ for any I and any D . It is associated to the subset containing all vertices or the outermost cycle in the diagram that does not pass through the basepoint.*

Observation 2.2.4. *If I is a disconnected resolution of D , and we choose to work over a completed ground ring, then the algebra associated to the I -resolution of D will vanish. In a disconnected resolution, there are cycles that do not contain the basepoint and have no ingoing or outgoing edges. In this situation, we interpret the products w_{out} and w_{in} to be 1, which makes the associated relation $t^k - 1$ for some k . In $\widehat{\mathcal{R}}$ or $\widehat{\mathcal{R}}[\underline{x}]$, $t^k - 1$ is a unit. Therefore, including $t^k - 1$ in our ideal of relations makes $\mathcal{A}_I(D) \otimes_{\mathcal{R}} \widehat{\mathcal{R}}$ or $\mathcal{A}_I(D) \otimes_{\mathcal{R}[\underline{x}]} \widehat{\mathcal{R}}[\underline{x}]$ vanish.*

2.3 Removing bivalent vertices

This section is devoted to a technical result allowing us to remove a horizontal layer of a diagram with a bivalent vertex on each strand and no 4-valent vertices. Such a layer is obtained each time a crossing is resolved. Suppose the I -resolution of D is a diagram with $m + 1$ layers, and that layer k contains only bivalent vertices. Let \bar{D} denote the diagram obtained by removing layer k . The proposition below shows that removing layer k corresponds to tensoring $\mathcal{A}_I(D)$ with the ground ring via a non-trivial automorphism. Note that applying this base change to every summand of the chain complex $C(D)$ does not change the homology of the complex, since \mathcal{R} is flat when considered as an \mathcal{R} -module via an automorphism. We refer to the notation in Figure 2.4 throughout.

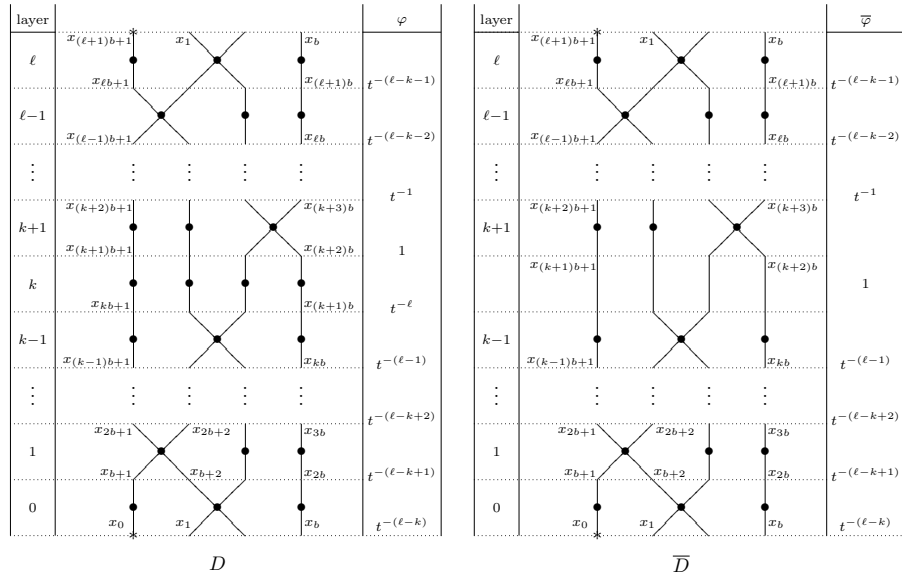

Figure 2.4: Diagrams for the proof of Proposition 2.3.1. The maps φ on $\mathcal{A}_I(D)$ and $\bar{\varphi}$ on $\mathcal{A}_{\bar{I}}(\bar{D})$ are defined to be multiplication by the factor shown in the right-most column of each diagram.

Proposition 2.3.1. *Let D and \bar{D} be defined as above. Let \bar{I} denote the index I with its k^{th} component deleted. Then there is an $\mathcal{R}[\underline{x}(\bar{D})]$ -module isomorphism $\mathcal{A}_{\bar{I}}(\bar{D}) \cong \mathcal{A}_I(D) \otimes_{(\mathcal{R}, \psi)} \mathcal{R}$, where ψ is the automorphism of \mathcal{R} taking 1 to 1 and t to $t^{m/(m+1)}$.*

Proof. We first define automorphisms φ of $\mathcal{A}_I(D)$ and $\bar{\varphi}$ of $\mathcal{A}_{\bar{I}}(\bar{D})$ that transform our original presentations of these algebras into presentations in which t appears very rarely. That ψ is the necessary automorphism of \mathcal{R} will then be apparent.

Define φ to be multiplication by $t^{-(j-1)}$ on edges $x_{(k+j)b+i}$ for $0 \leq j \leq m$ and $1 \leq i \leq b$ (treating the $k + j$ portion of the subscript modulo $m + 1$), and multiplication by $t^{-(m-k)}$ on edge

$x_{(m+1)b+1} = x_n$. That is, φ is the identity on the edges connecting layer k to layer $k+1$ (edges $x_{(k+1)b+1}, \dots, x_{(k+2)b}$), multiplication by t^{-1} on the edges connecting layer $k+1$ to layer $k+2$ (edges $x_{(k+2)b+1}, \dots, x_{(k+3)b}$), multiplication by t^{-2} on the edges connecting layer $k+2$ to layer $k+3$, and so on, until it is multiplication by t^{-m} on the edges connecting layer $k-1$ to layer k (edges $x_{kb+1}, \dots, x_{(k+1)b}$).

We may continue to use x_0, \dots, x_n as generators of $\varphi(\mathcal{A}_I(D))$, but must examine carefully the effect of φ on the generating sets of \mathcal{L} and $\mathcal{N}_I(D)$. Consider first the generators of \mathcal{L}_{k+j} for any $j \neq 0$. These have one of the following forms, where $1 \leq i \leq b$.

$$tx_{(k+j+1)b+i} + tx_{(k+j+1)b+i+1} - x_{(k+j)b+i} - x_{(k+j)b+i+1} \quad (2.3)$$

$$t^2x_{(k+j+1)b+i}x_{(k+j+1)b+i+1} - x_{(k+j)b+i}x_{(k+j)b+i+1} \quad (2.4)$$

$$tx_{(k+j+1)b+i} - x_{(k+j)b+i} \quad (2.5)$$

After applying φ , they become

$$\begin{aligned} & t^{-j+1}x_{(k+j+1)b+i} + t^{-j+1}x_{(k+j+1)b+i+1} - t^{-(j-1)}x_{(k+j)b+i} - t^{-(j-1)}x_{(k+j)b+i+1} \\ & \equiv x_{(k+j+1)b+i} + x_{(k+j+1)b+i+1} - x_{(k+j)b+i} - x_{(k+j)b+i+1} \end{aligned} \quad (2.6)$$

$$\begin{aligned} & t^{-2j+2}x_{(k+j+1)b+i}x_{(k+j+1)b+i+1} - t^{-2(j-1)}x_{(k+j)b+i}x_{(k+j)b+i+1} \\ & \equiv x_{(k+j+1)b+i}x_{(k+j+1)b+i+1} - x_{(k+j)b+i}x_{(k+j)b+i+1} \end{aligned} \quad (2.7)$$

$$\begin{aligned} & t^{-j+1}x_{(k+j+1)b+i} - t^{-(j-1)}x_{(k+j)b+i} \\ & \equiv x_{(k+j+1)b+i} - x_{(k+j)b+i}. \end{aligned} \quad (2.8)$$

The price of eliminating powers of t from most local relations is that t appears with higher powers in relations that do involve layer k . Since layer k has only bivalent vertices, its associated relations are all of the form $tx_{(k+1)b+i} - x_{kb+i}$. Applying φ , we obtain

$$tx_{(k+1)b+i} - t^{-m}x_{kb+i} \equiv t^{m+1}x_{(k+1)b+i} - x_{kb+i}.$$

Non-local relations are similarly affected. Consider the generating set for $\mathcal{N}_I(D)$ given by coherent regions. We will show that φ applied to any relation in this generating set produces a relation of the form $t^p w_{\text{out}} - w_{\text{in}}$ for some integer p . Begin with the innermost elementary region E_1 . Suppose it has v 4-valent vertices along its boundary in layers $k+j_1, \dots, k+j_v$. Then $\mathbf{w}(E_1) = m+1+v$. Each 4-valent vertex contributes one edge to the product w_{out} and an edge one layer lower to w_{in} .

If $j_i \neq 0$ for $1 \leq i \leq v$, then

$$\begin{aligned} \varphi(w_{\text{out}}) &= t^{-j_1 - \dots - j_v} w_{\text{out}} && \text{and} \\ \varphi(w_{\text{in}}) &= t^{-(j_1-1) - \dots - (j_v-1)} w_{\text{in}} = t^{-j_1 - \dots - j_v + v} w_{\text{in}}, && \text{so} \\ \varphi(t^{m+1+v} w_{\text{out}} - w_{\text{in}}) &\equiv t^{m+1} w_{\text{out}} - w_{\text{in}}. \end{aligned}$$

Suppose instead (without loss of generality) that $j_1 = 0$. Then φ is the identity when applied to the outgoing edge of the vertex in layer $k + j_1$, but multiplication by t^{-m} on the incoming edge. Therefore,

$$\begin{aligned} \varphi(w_{\text{out}}) &= t^{-j_2 - \dots - j_v} w_{\text{out}} && \text{and} \\ \varphi(w_{\text{in}}) &= t^{-m - (j_2-1) - \dots - (j_v-1)} w_{\text{in}} = t^{-m - j_2 - \dots - j_v + v - 1} w_{\text{in}}, && \text{so} \\ \varphi(t^{m+1+v} w_{\text{out}} - w_{\text{in}}) &\equiv t^{2(m+1)} w_{\text{out}} - w_{\text{in}}. \end{aligned}$$

So φ has the claimed effect on the non-local relation associated to the innermost coherent region.

Next consider an elementary region $E \neq E_1$ with bottom-most vertex in layer $k + j$ and top-most vertex in layer $k + j + s$. Suppose ∂E meets v' additional 4-valent vertices in layers $k + j_1, \dots, k + j_{v'}$. Assume for now that E does not meet layer k . Then $\mathbf{w}(E) = 2(s+1) + v'$. Let $t^{2(s+1)+v'} e_{\text{out}} - e_{\text{in}}$ denote the non-local relation associated to E . The top-most vertex of E contributes two outgoing edges to e_{out} and the bottom-most vertex contributes two incoming edges to e_{in} . The other v' 4-valent vertices contribute one edge each to e_{out} and e_{in} . Therefore,

$$\begin{aligned} \varphi(e_{\text{out}}) &= t^{-2(j+s) - j_1 - \dots - j_{v'}} e_{\text{out}} = t^{-2j - j_1 - \dots - j_{v'} - 2s} e_{\text{out}} && \text{and} \\ \varphi(e_{\text{in}}) &= t^{-2(j-1) - (j_1-1) - \dots - (j_{v'}-1)} e_{\text{in}} = t^{-2j - j_1 - \dots - j_{v'} + v' + 2} e_{\text{in}}, && \text{so} \\ \varphi\left(t^{2(s+1)+v'} e_{\text{out}} - e_{\text{in}}\right) &\equiv e_{\text{out}} - e_{\text{in}}. \end{aligned}$$

If E does meet layer k , a then modification of the calculation above (similar to that used for E_1) verifies the claim that $\varphi\left(t^{2(s+1)+v'} e_{\text{out}} - e_{\text{in}}\right)$ has the form $t^{p(m+1)} e_{\text{out}} - e_{\text{in}}$ for some integer p .

Finally, consider a coherent region R' that is not elementary. We can write R' as $R \cup E$, where R is a coherent region and E is an elementary region. Suppose the non-local relations associated to R and E are $t^{\mathbf{w}(R)} w_{\text{out}} - w_{\text{in}}$ and $t^{\mathbf{w}(E)} e_{\text{out}} - e_{\text{in}}$, respectively. Let y be the product of edges that connect vertices in R to vertices in E . The non-local relation associated to R' can be obtained by combining the non-local relations associated to R and E , then factoring out y as follows.

$$t^{\mathbf{w}(R)+\mathbf{w}(E)} w_{\text{out}} e_{\text{out}} - w_{\text{in}} e_{\text{in}} = y \left(t^{\mathbf{w}(R)+\mathbf{w}(E)} w'_{\text{out}} e'_{\text{out}} - w'_{\text{in}} e'_{\text{in}} \right)$$

The non-local relation associated to R' is $t^{\mathbf{w}(R)+\mathbf{w}(E)} w'_{\text{out}} e'_{\text{out}} - w'_{\text{in}} e'_{\text{in}}$. We will assume inductively that φ applied to the non-local relations for R and E produces $t^{p(m+1)} w_{\text{out}} - w_{\text{in}}$ and $t^{q(m+1)} e_{\text{out}} - e_{\text{in}}$,

respectively for some integers p and q . Then

$$\begin{aligned} & \varphi\left(t^{\mathbf{w}(R)+\mathbf{w}(E)}w_{\text{out}}e_{\text{out}} - w_{\text{in}}e_{\text{in}}\right) \\ & \equiv t^{(p+q)(m+1)}w_{\text{out}}e_{\text{out}} - w_{\text{in}}e_{\text{in}} \\ & = y\left(t^{(p+q)(m+1)}w'_{\text{out}}e'_{\text{out}} - w'_{\text{in}}e'_{\text{in}}\right) \end{aligned}$$

and on the other hand

$$\begin{aligned} & \varphi\left(t^{\mathbf{w}(R)+\mathbf{w}(E)}w_{\text{out}}e_{\text{out}} - w_{\text{in}}e_{\text{in}}\right) \\ & \equiv \varphi(y)\varphi\left(t^{\mathbf{w}(R)+\mathbf{w}(E)}w'_{\text{out}}e'_{\text{out}} - w'_{\text{in}}e'_{\text{in}}\right) \\ & \equiv y\varphi\left(t^{\mathbf{w}(R)+\mathbf{w}(E)}w'_{\text{out}}e'_{\text{out}} - w'_{\text{in}}e'_{\text{in}}\right). \end{aligned}$$

We have verified that applying φ to the non-local relation associated to R' produces a relation in which the power of t is an integer multiple of $m + 1$.

So far, we have relations of the following forms in our presentation of $\varphi(\mathcal{A}_I(D))$.

$$\begin{aligned} & x_{(k+j+1)b+i} + x_{(k+j+1)b+i+1} - x_{(k+j)b+i} - x_{(k+j)b+i+1} \\ & x_{(k+j+1)b+i}x_{(k+j+1)b+i+1} - x_{(k+j)b+i}x_{(k+j)b+i+1} \\ & x_{(k+j+1)b+i} - x_{(k+j)b+i} \\ & t^{m+1}x_{(k+1)b+i} - x_{kb+1} \\ & t^{p(m+1)}w_{\text{out}} - w_{\text{in}} \end{aligned} \tag{2.9}$$

It will be convenient to make one final modification: use the relations in (2.9) to eliminate the variables for edges connecting layer $k - 1$ to layer k . The result is a presentation in which t appears only in the following types of relations.

$$t^{m+1}x_{(k+1)b+i} + t^{m+1}x_{(k+1)b+i+1} - x_{(k-1)b+i} - x_{(k-1)b+i+1} \tag{2.10}$$

$$t^{2(m+1)}x_{(k+1)b+i}x_{(k+1)b+i+1} - x_{(k-1)b+i}x_{(k-1)b+i+1} \tag{2.11}$$

$$t^{m+1}x_{(k+1)b+i} - x_{(k-1)b+i} \tag{2.12}$$

$$t^{p(m+1)}w_{\text{out}} - w_{\text{in}} \tag{2.13}$$

The second map, $\bar{\varphi}$, allows us to present $\mathcal{A}_{\bar{I}}(\bar{D})$ in a similar way, with powers of t appearing only in certain relations, and only as t^{pm} for various integers p . Define $\bar{\varphi}$ in exactly the same way as φ on edges $x_{(k+j)b+i}$ for $1 \leq j \leq m$ and $0 \leq i \leq b$ and for edge $x_{(m+1)b+1}$. Diagram \bar{D} has no k^{th} layer, so $\bar{\varphi}$ is the identity on the edges connecting layer $k - 1$ to layer $k + 1$, multiplication by

t^{-1} on the edges connecting layer $k + 1$ to layer $k + 2$, multiplication by t^{-2} on the edges connecting layer $k + 2$ to $k + 3$, and so on, until it is multiplication by $t^{-(m-1)}$ on the edges connecting layer $k - 2$ to layer $k - 1$.

Again, for most relations, $\bar{\varphi}$ eliminates all powers of t . Similar calculations to those above show that $\bar{\varphi}$ removes t from the generating set for \mathcal{L}_{k+j} for $j \neq 0$, leaving relations identical to those in (2.6) to (2.8) above.

All powers of t end up in generators of \mathcal{L}_{k-1} and \mathcal{N}_I , but this time with multiples of m instead of $m + 1$. The relations that involve t have one of the following forms.

$$t^m x_{(k+1)b+i} + t^m x_{(k+1)b+i+1} - x_{(k-1)b+i} - x_{(k-1)b+i+1} \quad (2.14)$$

$$t^{2m} x_{(k+1)b+i} x_{(k+1)b+i+1} - x_{(k-1)b+i} x_{(k-1)b+i+1} \quad (2.15)$$

$$t^m x_{(k+1)b+i} - x_{(k-1)b+i} \quad (2.16)$$

$$t^{pm} w_{\text{out}} - w_{\text{in}} \quad (2.17)$$

We now have presentations of $\mathcal{A}_I(D)$ and $\mathcal{A}_{\bar{I}}(\bar{D})$, both over the smaller edge ring $\mathcal{R}[\underline{x}(\bar{D})]$, that differ only by whether t appears with a power of $m + 1$ or with m . The map needed to relate these two presentations is an automorphism of \mathcal{R} . Define $\psi : \mathcal{R} \rightarrow \mathcal{R}$ to take 1 to 1 and t to $t^{m/(m+1)}$. Applying ψ to the relations in (2.10)-(2.13) produces exactly the relations in (2.14)-(2.17). Since no other relations in our presentation of $\mathcal{A}_I(D)$ involve t , ψ has no effect on them. Therefore, $\varphi(\mathcal{A}_I(D)) \otimes_{(\mathcal{R}, \psi)} \mathcal{R}$ and $\bar{\varphi}(\mathcal{A}_{\bar{I}}(\bar{D}))$ have identical presentations as $\mathcal{R}[\underline{x}(\bar{D})]$ -modules. \square

2.4 Braid-like Reidemeister move II

Suppose D and \bar{D} are two knot projections that differ by a Reidemeister II move with labels as in Figure 2.5. The edge rings of D and \bar{D} are related by $\mathcal{R}[\underline{x}(D)] = \mathcal{R}[\underline{x}(\bar{D})][x_3, x_4, x_5, x_6]$. We will show that $C(D)$ and $C(\bar{D})$ are chain homotopy equivalent as complexes of $\mathcal{R}[\underline{x}(\bar{D})]$ -algebras, but will work over the larger edge ring $\mathcal{R}[\underline{x}(D)]$ for as long as possible. Throughout this section, we will abbreviate indices of resolutions to two entries, showing only the states of the crossings in layers s_i and s_{i+1} .

There are two oriented Reidemeister II moves, depending on which crossing in D is positive and which is negative, but the arguments are very similar in the two cases. The relevant portion of $C(D)$ is shown in Figure 2.6. The two variants of the Reidemeister II move exchange $\mathcal{A}_{00}(D)$ with $\mathcal{A}_{11}(D)$ and $\mathcal{A}_{01}(D)$ with $\mathcal{A}_{10}(D)$.

The key step in proving that the chain homotopy type of $C(D)$ is unchanged by a Reidemeister II move is to show the equivalence of the two complexes in Figure 2.6. It suffices to prove the statement

in Lemma 2.4.1, which asserts that (after a change of basis) $\mathcal{A}_{00}(D) \xrightarrow{f} \mathcal{A}_{10}(D) \xrightarrow{g} \mathcal{A}_{11}(D)$ is an acyclic subcomplex. Removing that subcomplex leaves the bottom complex of Figure 2.6. Removing the bivalent vertices in layers s_i and s_{i+1} (applying Proposition 2.3.1 and reverting to the edge ring $\mathcal{R}[\underline{x}(\overline{D})]$) leaves the corresponding portion of $C(\overline{D})$.

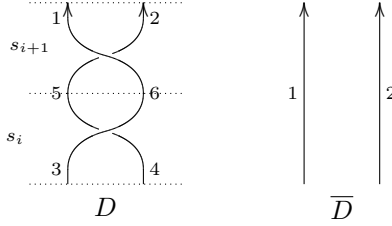

Figure 2.5: Projection D layers s_i and s_{i+1} and the corresponding portion of \overline{D} , which has no vertices. Technically, \overline{D} does not have layers corresponding to s_i and s_{i+1} ; it is identical to D in all other layers. Assume that the braid axis is to the right of each diagram.

Lemma 2.4.1. *As $\mathcal{R}[\underline{x}(\overline{D})][x_3, x_4]$ -modules, $\mathcal{A}_{10}(D) \cong \mathcal{A}_{00}(D) \oplus \mathcal{A}_{11}(D)$, f is an isomorphism onto the first summand, and g is an isomorphism when restricted to the second summand.*

Proof. The following matrix is a generating set for $\mathcal{L}_i + \mathcal{L}_{i+1}$ in the 10-resolution of D .

$$\begin{pmatrix} t(x_1 + x_2) - (x_5 + x_6) \\ (tx_1 - x_6)(tx_2 - x_6) \\ t(x_5 + x_6) - (x_3 + x_4) \\ (tx_6 - x_4)(x_3 - tx_6) \end{pmatrix}$$

Use row I to eliminate x_5 , then rewrite to limit the appearance of x_6 to a single row.

$$\begin{pmatrix} (tx_1 - x_6)(tx_2 - x_6) \\ t^2(x_1 + x_2) - (x_3 + x_4) \\ (tx_6 - x_4)(x_3 - tx_6) \end{pmatrix} \xrightarrow{\text{III} + t^2\text{I} + tx_6\text{II}} \begin{pmatrix} (tx_1 - x_6)(tx_2 - x_6) \\ t^2(x_1 + x_2) - (x_3 + x_4) \\ t^4x_1x_2 - x_3x_4 \end{pmatrix}$$

Let $\overline{\mathcal{L}}$ denote the ideal generated by the last two rows of the matrix above and \mathcal{L} denote the ideal generated by local relations in layers other than i and $i + 1$. Note that x_5 and x_6 do not appear in the generating set for \mathcal{L} . By Observation 2.2.2, they need not appear in a generating set for \mathcal{N}_{10} either. Therefore, these ideals survive the manipulations above unchanged. Define

$$\mathcal{S} = \frac{\mathcal{R}[x_0, \dots, x_4, x_7, \dots, x_n]}{\overline{\mathcal{L}} + \mathcal{L} + \mathcal{N}_{10}}.$$

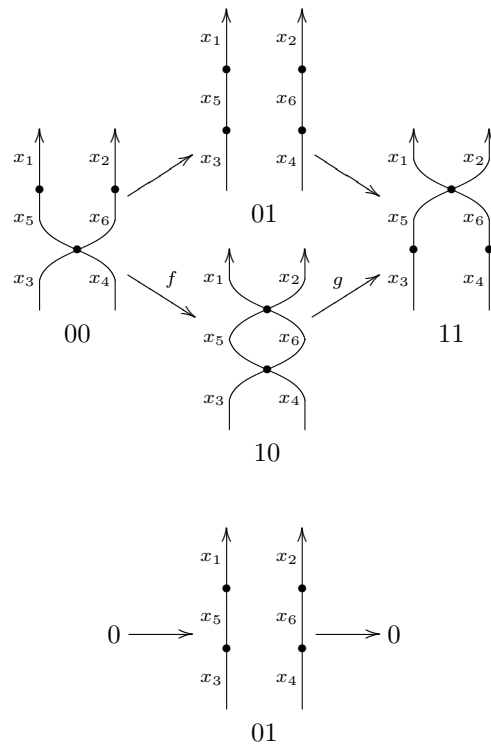

Figure 2.6: The top chain complex is a portion of $C(D)$. Lemma 2.4.1 shows that it is chain homotopy equivalent to the bottom chain complex. Assume that the braid axis is to the right of each diagram.

We have simplified the presentation of \mathcal{A}_{10} so that x_6 appears only in one relation, which is quadratic in x_6 . Using that relation, we may split \mathcal{A}_{10} as follows.

$$\mathcal{A}_{10}(D) \cong \frac{\mathcal{S}[x_6]}{(tx_1 - x_6)(tx_2 - x_6)} \cong \mathcal{S}(1) \oplus \mathcal{S}(tx_1 - x_6)$$

It remains to show that these two summands correspond to $\mathcal{A}_{11}(D)$ and $\mathcal{A}_{00}(D)$.

In the 11-resolution, the linear relations $tx_5 - x_3$ and $tx_6 - x_4$ may be used to replace x_5 and x_6 throughout the presentation. The resulting local relations in layers i and $i + 1$ exactly match those in $\bar{\mathcal{L}}$. The definition by coherent regions and Observation 2.2.2 give matching generating sets for \mathcal{N}_{10} and \mathcal{N}_{11} . Therefore, $\mathcal{A}_{11}(D)$ has a presentation identical to that of \mathcal{S} given above. Since g is defined to be the quotient map, it is an isomorphism when restricted to the first summand of $\mathcal{A}_{10}(D)$ above.

Similarly, in the 00-resolution, the linear relations $tx_1 - x_5$ and $tx_2 - x_6$ can be used to replace x_5 and x_6 throughout the presentation of $\mathcal{A}_{00}(D)$. For local relations in layers i and $i + 1$, the resulting ideal is exactly $\bar{\mathcal{L}}$. For non-local relations, the definition by coherent regions along with Observation 2.2.2 again gives the same generating set for \mathcal{N}_{00} as for \mathcal{N}_{10} . Therefore, $\mathcal{A}_{00}(D)$ has a presentation identical to \mathcal{S} . Since f is defined to be multiplication by $tx_1 - x_6$, it is an isomorphism onto the second summand of $\mathcal{A}_{10}(D)$ above. \square

2.5 Conjugation: Moving the basepoint

In this section we demonstrate that $\mathcal{A}_I(D)$ is invariant under conjugation of the braid diagram D . Since conjugation is a planar isotopy of a braid diagram, it does not change the edge ring or the local relations. However, our construction in Section 2.1 does rely on the choice of a basepoint, the special marking $*$, which has a role in determining which cycles, subsets, or regions are used to define non-local relations. Proving that the algebra $\mathcal{A}_I(D)$ is invariant under conjugation is equivalent to proving that it is invariant under moving the basepoint from one edge to another. Of course, it suffices to simply move the basepoint to an adjacent outermost edge, either past a bivalent vertex or past a singular crossing. Figures 2.7 and 2.8 show the two moves we must check.

Lemma 2.5.1. *Let D be the layered braid diagram for a braid word of the form $\sigma_i\sigma$, where $i \neq 1$ and σ is any braid word. Let D' be the layered braid diagram for $\sigma\sigma_i$. Fix edge labels as in Figure 2.7 with $p > n$. Then for any index I , $\mathcal{A}_I(D) \cong \mathcal{A}_I(D')$ as $\mathcal{R}[x]$ -algebras, where x acts as the variable associated to the vertex outgoing from the basepoint in each diagram.*

Proof. Whether σ_i is resolved or singularized in the I -resolution of D , the isotopy shown on the right indicates that it suffices to prove that we can move the basepoint across a bivalent vertex on

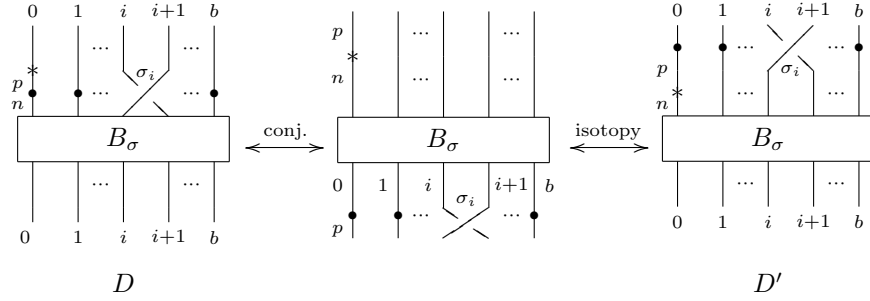

Figure 2.7: Diagram for Lemma 2.5.1: moving the basepoint across a bivalent vertex is equivalent to conjugating $\sigma_i \sigma$ to $\sigma \sigma_i$ for $i \neq 1$.

the left-most strand. Let x_0, \dots, x_n, x_p denote the variables in the edge ring for D and y_0, \dots, y_n, y_p denote the variables in the edge ring for D' . We will view $\mathcal{A}_I(D)$ and $\mathcal{A}_I(D')$ as $\mathcal{R}[x]$ -modules by equating x with x_0 and with y_p , respectively. Define an $\mathcal{R}[x]$ -module map $\varphi : \mathcal{A}_I(D) \rightarrow \mathcal{A}_I(D')$ by $x_0 \mapsto y_p$, $x_i \mapsto ty_i$ for $1 \leq i \leq n$, and $x_p \mapsto y_n$. To see that it is well-defined and an isomorphism, first notice that φ maps the linear relation $tx_p - x_n$ (coming from the bivalent vertex nearest the basepoint in D) to 0 in $\mathcal{A}_I(D')$. Now use the relation $tx_p - x_n$ to find a presentation of $\mathcal{A}_I(D)$ in which x_p does not appear. Suppose that $f(x_0, \dots, x_n)$ is one of the relations in this presentation. Then $\varphi(f(x_0, \dots, x_n)) = f(y_p, ty_1, \dots, ty_n) \equiv f(ty_0, ty_1, \dots, ty_n) \equiv f(y_0, y_1, \dots, y_n)$, where “ \equiv ” here means “generates the same ideal in $\mathcal{R}[y_0, \dots, y_n, y_p]/(ty_0 - y_p)$.” Since $ty_0 - y_p$ is a relation in $\mathcal{A}_I(D')$ (associated to the bivalent vertex nearest the basepoint), this calculation says that φ identifies each relation in the chosen presentation of $\mathcal{A}_I(D)$ with a relation in $\mathcal{A}_I(D')$. The map defined by $y_i \mapsto t^{-1}x_i$ for $(0 \leq i \leq n)$ and $y_p \mapsto x_0$ is an inverse for φ , which one can check is well-defined by a similar argument. \square

Lemma 2.5.2. *Let D be the layered braid diagram for a braid word of the form $\sigma_1 \sigma$, where σ is any braid word. Let D' be the layered braid diagram for $\sigma \sigma_1$. Fix edge labels as in Figure 2.8 and let $\underline{x}(B_\sigma)$ denote the edges in B_σ , including those adjacent to the box labeled B_σ . Then $C(D)$ and $C(D')$ are equivalent complexes of $\mathcal{R}[\underline{x}(B_\sigma)]$ -modules up to chain homotopy equivalence and base change.*

Proof. Figure 2.8 shows a sequence of moves that transforms D on the upper left to D' on the lower left via diagrams D_1, D_2, D_3, D_4 moving clockwise around the figure. Each move changes the corresponding chain complex by a base change (Proposition 2.3.1) or a chain homotopy equivalence (Lemma 2.4.1).

Let ℓ be the number of layers in D , which is also the number of layers in D' . By Proposition 2.3.1,

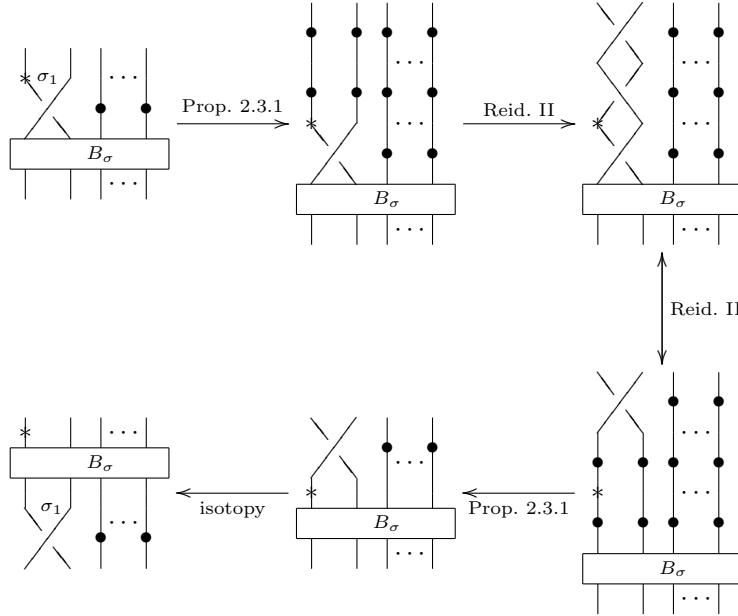

Figure 2.8: Diagrams for Lemma 2.5.2: conjugating $\sigma_1\sigma$ to $\sigma\sigma_1$ is equivalent to moving the basepoint across σ_1 .

$C(D_1) \cong C(D) \otimes_{(\mathcal{R}, \psi)} \mathcal{R}$, where ψ is the automorphism of \mathcal{R} that takes t to $t^{(\ell+2)/\ell}$. The next two diagrams are obtained by Reidemeister II moves. Lemma 2.4.1 shows that $C(D_2)$ is chain homotopy equivalent to $C(D_1)$.

The Reidemeister II move from D_2 to D_3 occurs across the basepoint, but Lemma 2.4.1 can be modified to apply in this situation. The key step in the modification is to use the relation $t^{\mathbf{w}(D)}x_n - x_0$, where x_n is the edge leaving the basepoint, and x_0 is the edge entering the basepoint. As noted in Observation 2.2.3, this relation is associated to the outermost cycle, and it holds in any resolution. After using this relation to eliminate x_n from all presentations, the proof of Lemma 2.4.1 goes through with only small modifications.

To go from D_3 to D_4 , we remove two layers of bivalent vertices. Proposition 2.3.1 implies that $C(D_4) \cong C(D_3) \otimes_{(\mathcal{R}, \psi^{-1})} \mathcal{R}$. Finally, D' is obtained by an isotopy, which does not change the chain complex. All together, we have that $C(D')$ is homotopy equivalent to $C(D) \otimes_{(\mathcal{R}, \psi)} \mathcal{R} \otimes_{(\mathcal{R}, \psi^{-1})} \mathcal{R} \cong C(D)$. \square

Although Lemma 2.5.2 is stated with an $\mathcal{R}[\underline{x}(B_\sigma)]$ -module isomorphism, its proof can be modified to give an $\mathcal{R}[x_0]$ -module isomorphism instead (as needed for the proof of Theorem 2.1.1) by preserving the edges nearest the basepoint when removing layers of bivalent vertices.

2.6 Braid-like Reidemeister move III

In this section, we will consider projections D_1 and D_2 that differ by a Reidemeister III move with all positive crossings and labeling as in Figure 2.9. Invariance under the other braid-like versions of Reidmeister III follows because all such moves are compositions of the positive Reidemeister III move and Reidemeister II moves.

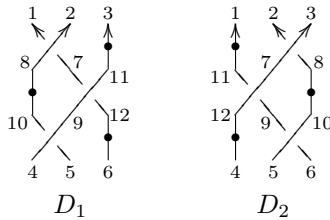
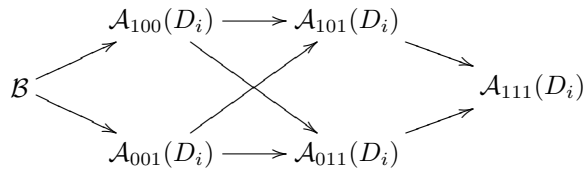

Figure 2.9: Diagrams D_1 and D_2 in layers s_1 , s_2 , and s_3 .

Figure 2.10 shows the relevant portion of the cube of resolutions associated to D_1 . Throughout this section, we will abbreviate indices to three places, conjugating the diagrams as necessary so that the Reidemeister III move occurs in layers s_1 , s_2 , and s_3 , and using the index to indicate the states of the crossings in those layers only.

The goal is to prove that the chain complexes $C(D_1)$ and $C(D_2)$ are chain homotopy equivalent. The strategy will be to prove that they are each chain homotopy equivalent to the following complex, which will be denoted $C(\Upsilon)$.



The module \mathcal{B} is a direct summand common to $\mathcal{A}_{000}(D_1)$ and $\mathcal{A}_{000}(D_2)$. The other modules in this simplified complex correspond to resolutions of D_1 and D_2 that are identical after removing extra layers of bivalent vertices. Specifically, notice that the 100-resolution of D_1 is isotopic to the 001-resolution of D_2 and vice versa; the 101-resolution of D_1 is isotopic to the 011-resolution of D_2 and vice versa; and the 111-resolutions of D_1 and D_2 are identical. After removing acyclic subcomplexes, we will find that the complex $C(\Upsilon)$ is common to both $C(D_1)$ and $C(D_2)$.

Only the argument that $C(D_1)$ is chain homotopy equivalent to $C(\Upsilon)$ will be given here in full detail since the computations needed to establish the same fact about D_2 are very similar. The

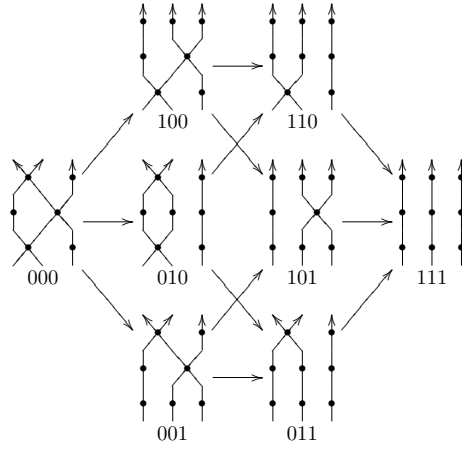
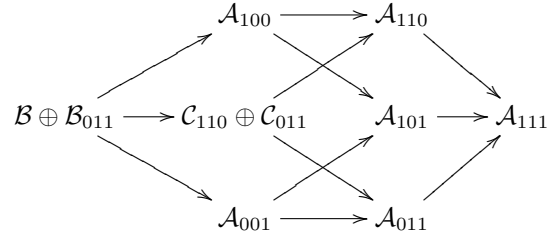

Figure 2.10: Portion of the cube of resolutions for D_1 in layers s_1 , s_2 , and s_3 .

main results of this section are Lemmas 2.6.1 and 2.6.2, which show that $C(D_1)$ and $C(D_2)$ both have the following form.



Moreover, these lemmas show that (after a suitable change of basis) there are acyclic subcomplexes $\mathcal{B}_{011} \xrightarrow{1} \mathcal{C}_{011}$ and $\mathcal{C}_{110} \xrightarrow{1} \mathcal{A}_{110}$. After these are removed, only the simplified complex $C(\Upsilon)$ remains.

Lemma 2.6.1. *The algebras associated to the 010-resolutions of D_1 and D_2 split as direct sums of $\mathcal{R}[x_0, \dots, x_6, x_{13}, \dots, x_n]$ -modules $\mathcal{A}_{010}(D_i) \cong \mathcal{C}_{110}(D_i) \oplus \mathcal{C}_{011}(D_i)$, where $\mathcal{C}_{110}(D_i) \cong \mathcal{A}_{110}(D_i)$. The edge map $\mathcal{A}_{010}(D_i) \rightarrow \mathcal{A}_{110}(D_i)$ is an isomorphism when restricted to the first summand of $\mathcal{A}_{010}(D_i)$.*

Lemma 2.6.2. *The algebras associated to the 000-resolutions of D_1 and D_2 split as direct sums of $\mathcal{R}[x_0, \dots, x_6, x_{13}, \dots, x_n]$ -modules $\mathcal{A}_{000}(D_i) \cong \mathcal{B} \oplus \mathcal{B}_{011}(D_i)$, where $\mathcal{B}_{011}(D_i) \cong \mathcal{C}_{011}(D_i)$. The edge map $\mathcal{A}_{000} \rightarrow \mathcal{A}_{010}$ restricted to $\mathcal{B}_{011}(D_i)$ is an isomorphism onto $\mathcal{C}_{011}(D_i)$, the second summand of \mathcal{A}_{010} in Lemma 2.6.1.*

Proof of Lemma 2.6.1. We know from Lemma 2.4.1 that \mathcal{A}_{010} splits as a direct sum of modules isomorphic to \mathcal{A}_{110} and \mathcal{A}_{011} . However, it will be useful to establish a particular splitting so that we may see directly the isomorphisms $\mathcal{C}_{110} \cong \mathcal{A}_{110}$ and (in the proof of Lemma 2.6.2) $\mathcal{C}_{011} \cong \mathcal{B}_{011}$.

The computations are similar to those used to prove Lemma 2.4.1. We first manipulate the local relations from the vertices in D_i to a convenient form, then obtain direct sum splittings by eliminating all quadratic and higher-order appearances of one variable, and keep track throughout of how these manipulations affect the non-local relations.

We begin with the presentation of \mathcal{A}_{010} as

$$\mathcal{A}_{010} \cong \frac{\mathcal{R}[x_0, \dots, x_n]}{\mathcal{L}_{123} + \mathcal{L} + \mathcal{N}_{010}},$$

where \mathcal{L}_{123} is generated by local relations from layers s_1 , s_2 , and s_3 , \mathcal{L} is generated by the local relations associated to other layers, and \mathcal{N}_{010} is generated by non-local relations. Note that \mathcal{L} is generated by relations that do not use any of x_7, \dots, x_{12} . It will not be affected by any of the calculations below. Thinking of non-local relations as coming from coherent regions, notice that x_7, \dots, x_{12} need not ever appear in a generating set for \mathcal{N}_{010} because any coherent region containing the elementary region to the right of x_7 and x_9 can be assumed to include the bigon bounded by edges x_7, x_8, x_9 , and x_{10} . The manipulations below will not affect such a generating set for \mathcal{N}_{010} .

The following matrix is a generating set for \mathcal{L}_{123} , with x_{11} and x_{12} already eliminated using linear relations $tx_3 - x_{11}$ and $tx_{12} - x_6$.

$$\begin{pmatrix} t(x_1 + x_2) - (x_7 + x_8) \\ t^2x_1x_2 - x_7x_8 \\ t^3x_3 - x_6 \\ tx_7 - x_9 \\ t(x_9 + x_{10}) - (x_4 + x_5) \\ (tx_9 - x_5)(x_4 - tx_9) \\ tx_8 - x_{10} \end{pmatrix}$$

Use row IV to eliminate x_7 , row VII to eliminate x_8 , and row V to eliminate x_{10} , then rearrange.

$$\begin{pmatrix} t(x_1 + x_2) - t^{-2}(x_4 + x_5) \\ t^2x_1x_2 + t^{-2}x_9^2 - t^{-3}x_9(x_4 + x_5) \\ t^3x_3 - x_6 \\ (tx_9 - x_5)(x_4 - tx_9) \end{pmatrix} \xrightarrow{\text{I}+t^{-2}\text{III and II}+t^{-4}\text{IV}} \begin{pmatrix} t(x_1 + x_2 + x_3) - t^{-2}(x_4 + x_5 + x_6) \\ t^2x_1x_2 - t^{-4}x_4x_5 \\ t^3x_3 - x_6 \\ (tx_9 - x_5)(x_4 - tx_9) \end{pmatrix}$$

Clear negative powers of t from all rows and symmetrize the presentation as follows.

$$\begin{array}{c} \left(\begin{array}{c} t^3(x_1 + x_2 + x_3) - (x_4 + x_5 + x_6) \\ t^6 x_1 x_2 - x_4 x_5 \\ t^3 x_3 - x_6 \\ (tx_9 - x_5)(x_4 - tx_9) \end{array} \right) \\ \downarrow \text{II} + t^3(x_1 + x_2) \text{III} + x_6 \text{I} - x_6 \text{III} \\ \left(\begin{array}{c} t^3(x_1 + x_2 + x_3) - (x_4 + x_5 + x_6) \\ t^6 \sigma_2(x_1, x_2, x_3) - \sigma_2(x_4, x_5, x_6) \\ t^3 x_3 - x_6 \\ (tx_9 - x_5)(x_4 - tx_9) \end{array} \right) \end{array}$$

where σ_2 is the second elementary symmetric polynomial.

Let $\overline{\mathcal{L}}_{123}$ denote the ideal generated by the first two rows above and $q = (tx_9 - x_5)(x_4 - tx_9)$. Notice that $\overline{\mathcal{L}}_{123}$ is generated by relations that do not use any of x_7, \dots, x_{12} . Define

$$\mathcal{T} = \frac{\mathcal{R}[x_0, \dots, x_6, x_{13}, \dots, x_n]}{\mathcal{L} + \overline{\mathcal{L}}_{123}}.$$

So far, we have established that

$$\mathcal{A}_{010} \cong \frac{\mathcal{T}[x_9]}{(q) + (t^3 x_3 - x_6) + \mathcal{N}_{010}}$$

and that x_9 appears only in q . Since q is quadratic in x_9 , we could use it to replace any appearance of x_9^k for $k \geq 2$ in a presentation of \mathcal{A}_{010} with some polynomial that was linear in x_9 . However, we have already eliminated all appearances of x_9 from the rest of the presentation. Therefore, we may forget the relation q , and split \mathcal{A}_{010} into a summand generated by 1 and a summand generated by a polynomial that is linear in x_9 .

$$\mathcal{A}_{010} \cong \frac{\mathcal{T}(1)}{(t^3 x_3 - x_6) + \mathcal{N}_{010}} \oplus \frac{\mathcal{T}(tx_9 - x_5)}{(t^3 x_3 - x_6) + \mathcal{N}_{010}}.$$

With the first summand as \mathcal{C}_{110} and the second as \mathcal{C}_{011} , this is the splitting asserted in the statement of the lemma.

We now check that $\mathcal{A}_{110} \cong \mathcal{C}_{110} = \frac{\mathcal{T}(1)}{(t^3 x_3 - x_6) + \mathcal{N}_{010}}$ by simplifying the presentation of \mathcal{A}_{110} . First note that x_7, \dots, x_{12} do not appear in any local relations associated to layers s_i for $i > 3$. They also need not appear in a minimal generating set for \mathcal{N}_{110} . If a subset had one of these as an outgoing or incoming edge, we use the relations associated to bivalent vertices in layers s_1 and s_2 to eliminate them from the associated relation. Turning to \mathcal{L}_{123} , eliminate x_{11} and x_{12} immediately using the

linear relations on the rightmost strand, then remove x_7, \dots, x_{10} as follows.

$$\begin{array}{c} \left(\begin{array}{c} tx_1 - x_8 \\ tx_2 - x_7 \\ t^3x_3 - x_6 \\ tx_7 - x_9 \\ tx_8 - x_{10} \\ t(x_9 + x_{10}) - (x_4 + x_5) \\ (tx_9 - x_4)(x_5 - tx_9) \end{array} \right) \\ \downarrow \text{I+II+t}^{-2}\text{III+t}^{-1}\text{IV+t}^{-1}\text{V+t}^{-2}\text{VI} \\ \left(\begin{array}{c} t(x_1 + x_2 + x_3) - t^{-2}(x_4 + x_5 + x_6) \\ tx_2 - x_7 \\ t^3x_3 - x_6 \\ tx_7 - x_9 \\ tx_8 - x_{10} \\ t(x_9 + x_{10}) - (x_4 + x_5) \\ (tx_9 - x_4)(x_5 - tx_9) \end{array} \right) \end{array}$$

Simplify by multiplying the first row by t^2 , using row II to eliminate x_7 , using row V to eliminate x_8 and using row VI to eliminate x_{10} .

$$\left(\begin{array}{c} t^3(x_1 + x_2 + x_3) - (x_4 + x_5 + x_6) \\ t^3x_3 - x_6 \\ t^2x_2 - x_9 \\ (tx_9 - x_4)(x_5 - tx_9) \end{array} \right)$$

Now use row III to eliminate x_9 .

$$\begin{array}{c} \left(\begin{array}{c} t^3(x_1 + x_2 + x_3) - (x_4 + x_5 + x_6) \\ t^3x_3 - x_6 \\ (t^3x_2 - x_4)(x_5 - t^3x_2) \end{array} \right) \\ \downarrow \text{III+t}^3(x_2+x_3)\text{I+(}x_4+x_5-t^3(x_2+x_3)\text{)II} \\ \left(\begin{array}{c} t^3(x_1 + x_2 + x_3) - (x_4 + x_5 + x_6) \\ t^3x_3 - x_6 \\ t^6\sigma_2(x_1, x_2, x_3) - \sigma_2(x_4, x_5, x_6) \end{array} \right) \end{array}$$

The top and bottom rows are the generators of $\overline{\mathcal{L}}_{123}$. Therefore, we have

$$\mathcal{A}_{110} \cong \frac{\mathcal{T}}{(t^3x_3 - x_6) + \mathcal{N}_{110}}.$$

It remains to check that $\mathcal{N}_{110} = \mathcal{N}_{010}$. Figure 2.11 shows how the cycles that pass through the 010-resolution of D_1 pair up with the cycles that pass through the 110-resolution of D_1 to give equivalent non-local relations. Any cycle that does not pass through this region certainly has the same associated non-local relation in \mathcal{N}_{010} and \mathcal{N}_{110} . We have identified identical generating sets for \mathcal{N}_{010} and \mathcal{N}_{110} . Therefore, \mathcal{A}_{110} and \mathcal{C}_{110} have identical presentations. Since the edge map from \mathcal{A}_{010} to \mathcal{A}_{110} is defined to be the quotient map, it is an isomorphism when restricted to \mathcal{C}_{110} . \square

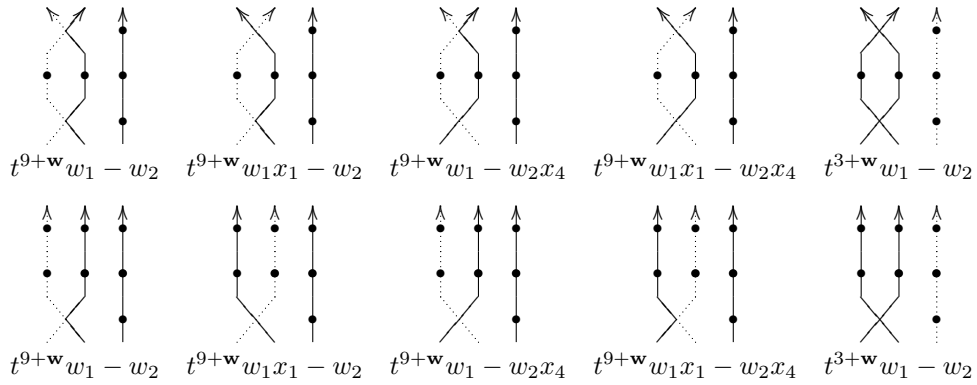

Figure 2.11: Pairing of cycles that pass through the 010-resolution (top row) and the 110-resolution (bottom row) of D_1 . In each local picture, \mathbf{w} is the weight, w_1 is the product of outgoing edges, and w_2 is the product of incoming edges for the portion of the cycle away from the portion of D_1 that is shown here.

The proof of Lemma 2.6.2 is similar, except that more work is required to keep track of the non-local relations. As before, we use local relations associated to layers s_1 , s_2 , and s_3 in \mathcal{A}_{000} to eliminate several edge variables, then use a quadratic relation to split \mathcal{A}_{000} as a direct sum, and finally check that one of the direct summands is in fact isomorphic to \mathcal{C}_{011} .

Proof of Lemma 2.6.2. Let \mathcal{L}_{123} denote the ideal generated by local relations associated to layers s_1 , s_2 , and s_3 , while \mathcal{L} denotes the ideal generated by local relations associated to all other layers. As before, \mathcal{N}_{000} will denote the ideal generated by non-local relations in the 000-resolution. So we begin with

$$\mathcal{A}_{000} \cong \frac{\mathcal{R}[x_0, \dots, x_n]}{\mathcal{L} + \mathcal{L}_{123} + \mathcal{N}_{000}}.$$

The general strategy will be to eliminate x_7, \dots, x_{12} from the presentation of \mathcal{A}_{000} and limit use of x_9 as much as possible. We will then rewrite \mathcal{A}_{000} in the form $\mathcal{T}[x_9]/\mathcal{I}$ for an appropriate ideal \mathcal{I} , where \mathcal{T} is the same algebra defined in the proof of Lemma 2.6.2. Finally, we will use the quadratic relation associated to layer s_3 , which is $(tx_9 - x_4)(x_5 - tx_9)$, to split \mathcal{A}_{000} into direct summands generated by 1 and $t^2x_3 - x_9$.

Notice first that no part of this strategy will affect the ideal \mathcal{L} . Edges x_7, \dots, x_{12} connect layer s_1 to layer s_2 or layer s_2 to layer s_3 , so they do not appear in local relations associated to any other layers.

For the relations in \mathcal{L}_{123} , first use the relations $tx_3 - x_{11}$ and $tx_{12} - x_6$ to replace x_{11} and x_{12} . Then the following matrix is a generating set for \mathcal{L}_{123} in the 000-resolution of D_1 , which we transform via $\text{I} + t^{-1}\text{III} + t^{-2}\text{V} + t^{-1}\text{VII}$.

$$\begin{pmatrix} t(x_1 + x_2) - (x_7 + x_8) \\ (tx_2 - x_7)(x_8 - tx_2) \\ t(tx_3 + x_7) - (t^{-1}x_6 + x_9) \\ (t^3x_3 - x_6)(t^{-1}x_9 - tx_3) \\ t(x_9 + x_{10}) - (x_4 + x_5) \\ (tx_9 - x_5)(tx_9 - x_4) \\ tx_8 - x_{10} \end{pmatrix} \longrightarrow \begin{pmatrix} t(x_1 + x_2 + x_3) - t^{-2}(x_4 + x_5 + x_6) \\ (tx_2 - x_7)(x_8 - tx_2) \\ t(tx_3 + x_7) - (t^{-1}x_6 + x_9) \\ (t^3x_3 - x_6)(t^{-1}x_9 - tx_3) \\ t(x_9 + x_{10}) - (x_4 + x_5) \\ (tx_9 - x_5)(tx_9 - x_4) \\ tx_8 - x_{10} \end{pmatrix}$$

Next, multiply row I by t^2 , use row III to eliminate x_7 , use row V to eliminate x_{10} , and use row VII to eliminate x_8 , then multiply row II by t^4 .

$$\begin{pmatrix} t^3(x_1 + x_2 + x_3) - (x_4 + x_5 + x_6) \\ (t^3(x_2 + x_3) - x_6 - tx_9)(x_4 + x_5 - tx_9 - t^3x_2) \\ (t^3x_3 - x_6)(t^{-1}x_9 - tx_3) \\ (tx_9 - x_5)(tx_9 - x_4) \end{pmatrix}$$

Use row IV to replace $t^2x_9^2$ in row II, then add $t^2\text{III}$ and $t^3(x_2 + x_3)\text{I}$ to row II, and then multiply row III by t to obtain

$$\begin{pmatrix} t^3(x_1 + x_2 + x_3) - (x_4 + x_5 + x_6) \\ t^6\sigma_2(x_1, x_2, x_3) - \sigma_2(x_4, x_5, x_6) \\ (t^3x_3 - x_6)(x_9 - t^2x_3) \\ (tx_9 - x_5)(tx_9 - x_4) \end{pmatrix}$$

where σ_2 is the second elementary symmetric polynomial. As in the proof of Lemma 2.6.1, let $\overline{\mathcal{L}}_{123}$ denote the ideal generated by the relations in rows I and II, and recall that $\overline{\mathcal{L}}_{123}$ is generated by relations that do not use x_9 . Let $p = (t^3x_3 - x_6)(x_9 - t^2x_3)$ and $q = (tx_9 - x_5)(tx_9 - x_4)$. Then we

have reduced the original generating set for \mathcal{L}_{123} to a generating set that does not involve x_9 , the quadratic relation q that will be used to split \mathcal{A}_{000} as a direct sum, and the relation p , which we will have to follow up carefully. So far, we have

$$\mathcal{A}_{000} \cong \frac{\mathcal{T}[x_7, \dots, x_{12}]}{(p) + (q) + \mathcal{N}_{000}}.$$

Using the coherent regions definition for the generators of \mathcal{N}_{000} , we can split \mathcal{N}_{000} into a sum of five ideals based on types of coherent regions. Label the elementary regions in the vicinity of the Reidemeister III move as in Figure 2.12. As usual, assume that the braid axis is to the right of the diagram. Let \mathcal{N} be the ideal generated by the relations from coherent regions that do not use any of E_1, E_2, E_3 , or E_4 . None of these relations use edge variables x_7, \dots, x_{12} , so they will carry through all of our calculations unchanged.

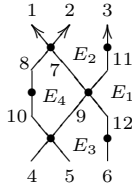

Figure 2.12: Elementary regions in the vicinity of the Reidemeister III move in the 000-resolution of D_1 .

Let \mathcal{E}_{1234} be generated by relations from coherent regions that use all of E_1, E_2, E_3 , and E_4 . These relations use x_1 and x_4 , but not any of x_7, \dots, x_{12} , so they carry through our calculations unchanged. The ideal \mathcal{E}_{1234} also accounts for relations associated to coherent regions that contain E_1, E_2 , and E_3 . Adding E_4 to such a region would add only the bivalent vertex between edges 8 and 10, which is exactly the situation described in Observation 2.2.2. Therefore, we need not consider coherent regions that contain E_1, E_2 , and E_3 without E_4 in a minimal generating set for \mathcal{N}_{000} .

Let \mathcal{E}_{12} (respectively \mathcal{E}_{13}) be generated by non-local relations from coherent regions that use E_1 and E_2 , but not E_3 or E_4 (respectively E_1 and E_3 but not E_2 or E_4). Some of the edge variables x_7, \dots, x_{12} do appear in the relations associated to such regions, but can be easily eliminated using the quadratic relations from layers s_1 or s_3 as appropriate. Figure 2.13 shows the necessary calculations in each case.

Finally, let \mathcal{E}_1 be generated by relations from coherent regions that use E_1 but none of E_2, E_3 , or E_4 , as shown in Figure 2.14. These relations have the form $t^{4+\mathbf{w}}w_{\text{out}}x_7 - w_{\text{in}}x_9$, where \mathbf{w} , w_{out} , and w_{in} come from pieces of the coherent region not shown in Figure 2.14. We will not be able to

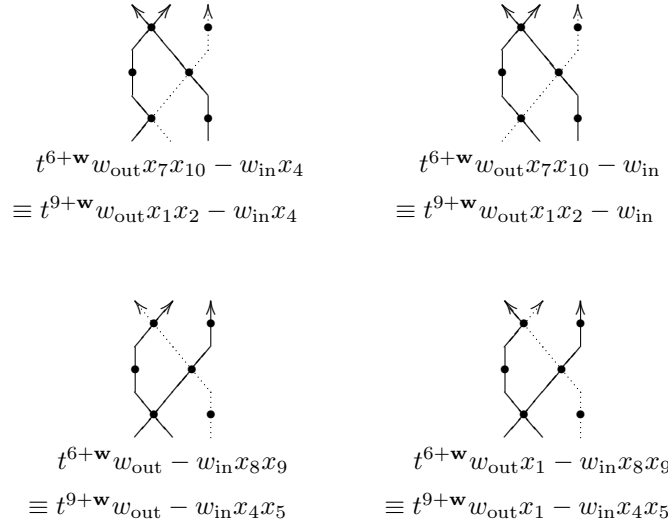

Figure 2.13: Relations that generate \mathcal{E}_{12} and \mathcal{E}_{13} , along with modifications to avoid the use of x_7, \dots, x_{12} . In each diagram, \mathbf{w} , w_{out} , and w_{in} come from the portions of the cycle not shown in these local pictures. Assume the braid axis is to the right in each diagram.

simultaneously eliminate x_7, \dots, x_{12} from these relations, but we can eliminate all but x_9 using the linear relations from the crossing in layer s_2 and linear relations associated to bivalent vertices. In fact, we can write any generator of \mathcal{E}_1 in the form $t^{2+\mathbf{w}} w_{\text{out}} (x_6 - t^3 x_3) + x_9 (t^{3+\mathbf{w}} w_{\text{out}} - w_{\text{in}})$, where w_{out} and w_{in} are words in $x_0, \dots, x_6, x_{13}, \dots, x_n$ only.

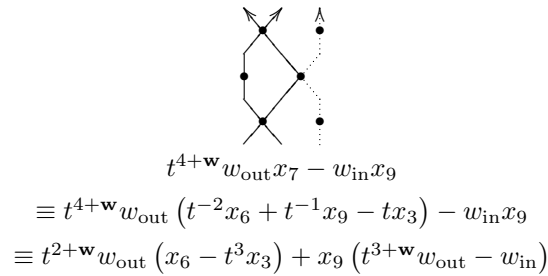

Figure 2.14: Removing x_7 from relations that generate \mathcal{E}_1 .

We have exhausted the possible combinations of elementary regions E_1, \dots, E_4 that can appear

in a coherent region, so we may now express \mathcal{N}_{000} as

$$\mathcal{N}_{000} = \mathcal{N} + \mathcal{E}_{1234} + \mathcal{E}_{12} + \mathcal{E}_{13} + \mathcal{E}_1.$$

Moreover, we have eliminated all appearances of x_7, \dots, x_{12} from the generating sets of \mathcal{N} , \mathcal{E}_{1234} , \mathcal{E}_{12} , and \mathcal{E}_{13} . Defining \mathcal{T}' by

$$\frac{\mathcal{T}}{\mathcal{E}_{12} + \mathcal{E}_{13} + \mathcal{E}_{1234} + \mathcal{N}}$$

we then have a presentation of \mathcal{A}_{000} as

$$\mathcal{A}_{000} \cong \frac{\mathcal{T}'[x_9]}{(p) + (q) + \mathcal{E}_1}.$$

The next step will be to use q to split \mathcal{A}_{000} as a direct sum of \mathcal{R} -modules, one of which is generated by 1 and one of which is generated by $t^2x_3 - x_9$. In other words, we would like to find ideals \mathcal{P}^1 , \mathcal{P}^x , \mathcal{E}_1^1 , and \mathcal{E}_1^x in \mathcal{T}' such that

$$\frac{\mathcal{T}'[x_9]}{(p) + (q) + \mathcal{E}_1} \cong \frac{\mathcal{T}'(1)}{\mathcal{P}^1 + \mathcal{E}_1^1} \oplus \frac{\mathcal{T}'(t^2x_3 - x_9)}{\mathcal{P}^x + \mathcal{E}_1^x}$$

as \mathcal{R} -modules.

As in the proof of Lemma 2.6.1, we may use q to replace any appearance of x_9^k for $k \geq 2$ with a polynomial that is linear in x_9 . This procedure has no effect on the ideals from which x_9 has been eliminated, but it does affect (p) and \mathcal{E}_1 . To analyze how, think of the ideal that p generates in $\mathcal{T}'[x_9]/(q)$ as the sum of the ideals generated by p and x_9p . If we use q to eliminate any appearances of x_9^2 in these generating sets, then we can find appropriate generators for \mathcal{P}^1 and \mathcal{P}^x by writing p and x_9p in terms of 1 and $t^2x_3 - x_9$. Actually, $p = (t^3x_3 - x_6)(x_9 - t^2x_3)$ is already in the correct format, so let $t^3x_3 - x_6$ be one of the generators of \mathcal{P}^x . For x_9p , we first calculate $x_9(x_9 - t^2x_3)$, replacing x_9 using q , then eliminating a term using p .

$$\begin{aligned} & x_9(x_9 - t^2x_3) \\ &= t^{-1}x_9x_4 + t^{-1}x_9x_5 - t^{-2}x_4x_5 - t^2x_3x_9 \\ &= (x_9 - t^2x_3)(t^{-1}x_4 + t^{-1}x_5 - t^2x_3) - t^{-2}x_4x_5 - t^4x_3^2 + tx_3x_4 + tx_3x_5 \\ &\equiv t^3x_3x_4 + t^3x_3x_5 - t^6x_3^2 - x_4x_5 \\ &= (t^3x_3 - x_4)(x_5 - t^3x_3) \end{aligned} \tag{2.18}$$

Therefore, the ideal generated by x_9p in $\mathcal{S}[x_9]/(q)$ is equal to the ideal generated by $(t^3x_3 - x_4)(x_5 - t^3x_3)(t^3x_3 - x_6)$, which no longer uses x_9 . Let \mathcal{P}^1 be the ideal generated by this relation in \mathcal{T}' . Adding this generator to \mathcal{P}^x would not change the ideal, since \mathcal{P}^x already has $t^3x_3 - x_6$ as a generator.

We use the same strategy to find appropriate generators for \mathcal{E}_1^1 and \mathcal{E}_1^x . Generators of \mathcal{E}_1 have the form $f = t^{\mathbf{w}+4}w_{\text{out}}x_7 - w_{\text{in}}x_9$. We would like to write f and x_9f in terms of 1 and $t^2x_3 - x_9$.

We have already seen that

$$f \equiv t^{2+\mathbf{w}}w_{\text{out}}(x_6 - t^3x_3) + x_9(t^{3+\mathbf{w}}w_{\text{out}} - w_{\text{in}}),$$

where w_{out} and w_{in} are words in $x_0, \dots, x_6, x_{13}, \dots, x_n$ only. Factoring out $x_9 - t^2x_3$ yields

$$f \equiv (x_9 - t^2x_3)(t^{3+\mathbf{w}}w_{\text{out}} - w_{\text{in}}) + t^2(t^{\mathbf{w}}w_{\text{out}}x_6 - w_{\text{in}}x_3).$$

Conveniently, the second term is a multiple of a generator of \mathcal{N} obtained as follows. Suppose f came from a coherent region R . Let V_R be the set of vertices contained in the closure of R , so that f is the relation associated to V_R under the subset interpretation of the non-local relations. Delete from V_R the 4-valent vertex in layer s_2 , the bivalent vertex between edges 3 and 11, and the bivalent vertex between edges 12 and 6. These deletions drop the weight of V_R by 4. The resulting set of vertices has the same incoming and outgoing edges as V_R except that x_7 has been replaced by x_6 and x_9 has been replaced by x_3 . Therefore, the relation associated to this subset, which must appear in \mathcal{N} , is exactly $t^{\mathbf{w}}w_{\text{out}}x_6 - w_{\text{in}}x_3$. The above expression for f then simplifies to

$$(x_9 - t^2x_3)(t^{3+\mathbf{w}}w_{\text{out}} - w_{\text{in}}). \quad (2.19)$$

We conclude that a generating set for \mathcal{E}_1^x should include $t^{3+\mathbf{w}}w_{\text{out}} - w_{\text{in}}$.

Next consider x_9f , using the final expression for f obtained in Equation 2.19 and the expression for $x_9(x_9 - t^2x_3)$ obtained in Equation 2.18.

$$\begin{aligned} x_9f &= x_9(x_9 - t^2x_3)(t^{3+\mathbf{w}}w_{\text{out}} - w_{\text{in}}) \\ &\equiv (t^3x_3 - x_4)(x_5 - t^3x_3)(t^{3+\mathbf{w}}w_{\text{out}} - w_{\text{in}}) \end{aligned} \quad (2.20)$$

These calculations eliminate all appearances of x_7, \dots, x_{12} from x_9f . Since we have already put $t^{3+\mathbf{w}}w_{\text{out}} - w_{\text{in}}$ in the generating set of \mathcal{E}_1^x , Equation 2.20 is automatically included. Let \mathcal{E}_1^1 be the ideal generated in \mathcal{T} by $(t^3x_3 - x_4)(x_5 - t^3x_3)(t^{3+\mathbf{w}}w_{\text{out}} - w_{\text{in}})$.

We have now split \mathcal{A}_{000} as a direct sum of \mathcal{R} -modules:

$$\mathcal{A}_{000} \cong \frac{\mathcal{T}'(1)}{\mathcal{P}^1 + \mathcal{E}_1^1} \oplus \frac{\mathcal{T}'(t^2x_3 - x_9)}{\mathcal{P}^x + \mathcal{E}_1^x}.$$

Define \mathcal{B} to be the first summand and \mathcal{B}_{011} to be the second.

It remains only to check that $\mathcal{B}_{011} \cong \mathcal{C}_{011}$. So far, we have a presentation of \mathcal{B}_{011} as

$$\mathcal{B}_{011} \cong \frac{\mathcal{T}}{\mathcal{E}_{12} + \mathcal{E}_{13} + \mathcal{E}_{1234} + \mathcal{N} + \mathcal{P}_1^x + \mathcal{E}_1^x}.$$

The proof of Lemma 2.6.1 gave a presentation of \mathcal{C}_{011} as

$$\mathcal{C}_{011} \cong \frac{\mathcal{T}}{(t^3x_3 - x_6) + \mathcal{N}_{010}}.$$

By definition, $\mathcal{P}^x = (t^3x_3 - x_6)$, so the work is entirely in checking that the non-local relations in the 010-resolution are the same as those in \mathcal{B}_{011} .

Use the coherent regions definition of the non-local relations with elementary regions labeled as in Figure 2.15 to classify the generators of \mathcal{N}_{010} . Coherent regions that do not use any of F_1, F_2 , or F_3 match one to one with coherent regions in the 000-resolution that do not use any of E_1, E_2, E_3 , or E_4 and give the same non-local relations. By Observation 2.2.2, coherent regions that use F_1 and F_2 may as well use F_3 . These match one to one with the regions that define \mathcal{E}_{1234} and give the same relations. Finally, the coherent regions that use only F_1 give generators for \mathcal{N}_{010} with exactly the form of generators for \mathcal{E}_1^x . Therefore, $\mathcal{N}_{010} = \mathcal{E}_{1234} + \mathcal{N} + \mathcal{E}_1^x$.

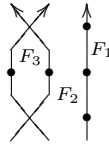

Figure 2.15: Elementary regions in the 010-resolution of D_1 .

The remaining ideals \mathcal{E}_{12} and \mathcal{E}_{13} were necessary to generate \mathcal{N}_{000} but are in fact redundant in the summand \mathcal{B}_{011} . The relations from Figure 2.13 used to define \mathcal{E}_{12} and \mathcal{E}_{13} correspond to subsets in the 010-resolution as follows. Suppose $R \cup E_1 \cup E_i$ is a coherent region for a generator of \mathcal{E}_{12} or \mathcal{E}_{13} . Let $V_{R \cup E_1 \cup E_i}$ be the corresponding subset in the 000-resolution. Let $V'_{R \cup E_1 \cup E_i}$ be the same subset of vertices in the 010-resolution, but with the 4-valent vertex in layer s_2 replaced by the two bivalent vertices created by resolving it. Then $V'_{R \cup E_1 \cup E_i}$ yields the same relation in \mathcal{N}_{010} as $R \cup E_1 \cup E_i$ did in \mathcal{N}_{000} . Figure 2.16 shows what these subsets look like in the vicinity of the Reidemeister move and how they correspond to the appropriate relations.

Having completed the verification that $\mathcal{N}_{010} = \mathcal{E}_{1234} + \mathcal{N} + \mathcal{E}_1^x + \mathcal{E}_{12} + \mathcal{E}_{13}$, we have now showed that \mathcal{C}_{011} and \mathcal{B}_{011} have identical presentations. Since the edge map $\mathcal{A}_{000} \rightarrow \mathcal{A}_{010}$ is by definition the quotient map, it is an isomorphism when restricted to $\mathcal{B}_{011} \rightarrow \mathcal{C}_{011}$. \square

2.7 Stabilization / Reidemeister move I

Let D and D^+ (respectively D^-) be knot projections that differ by a positive (respectively negative) stabilization with labels as shown in Figure 2.17. In this section, we prove that $C(D^+)$ and $C(D^-)$ are chain homotopy equivalent to $C(D)$ as complexes of $\widehat{\mathcal{R}}[\underline{x}(D)]$ -modules. The proof presented here

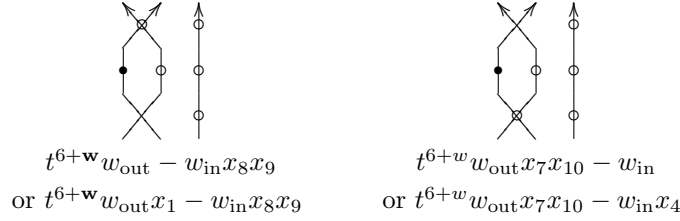

Figure 2.16: Subsets (shown with open circles) in the 010-resolution of D_1 that yield the relations corresponding to coherent regions in the 000-resolution that generate \mathcal{E}_{12} (left) and \mathcal{E}_{13} (right). As usual, \mathbf{w} , w_{in} , and w_{out} refer to the portion of the subset not shown in these local diagrams.

requires the completion of the ground ring because we invert an element of the form $1 - t^k$, but it is interesting to note that invariance under all of the other Markov moves holds over \mathcal{R} .

Since we have already established invariance under conjugation, we may assume that the stabilization occurs in layer s_0 . By Section 2.6, we may assume it occurs on the outermost strand. As shown in Figure 2.18, any resolution in which the crossing in layer s_0 is smoothed is disconnected, so by Observation 2.2.4, the associated algebra will vanish. Therefore, it suffices to show that the algebra associated to the I -resolution of D is isomorphic to the algebra associated to the corresponding resolution of D^+ or D^- in which s_0 is singular.

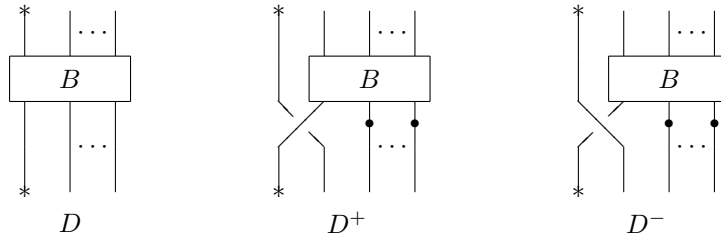

Figure 2.17: Diagrams D , D^+ , and D^- . Assume the braid axis is to the right of each picture and all strands are oriented upwards.

We proceed via an intermediary diagram D^\bullet shown on the right in Figure 2.18. To go from D^\bullet back to D , first remove the layer of bivalent vertices just above the basepoint. By Proposition 2.3.1, this transforms $\mathcal{A}_J(D^\bullet)$ to $\mathcal{A}_J(D^\bullet) \otimes_{(\mathcal{R}, \psi)} \mathcal{R}$. Use the linear relation $tx_n - x_1$ to remove x_1 from the presentation of $\mathcal{A}_J(D^\bullet) \otimes_{(\mathcal{R}, \psi)} \mathcal{R}$ without changing its isomorphism type. This process leaves exactly diagram D .

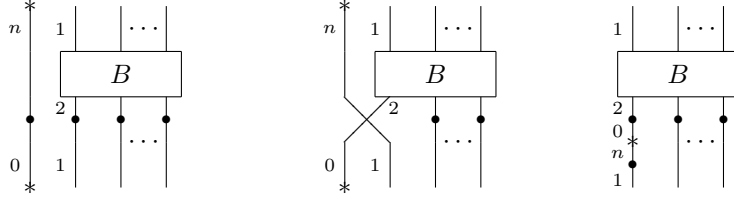

Figure 2.18: From left to right: the smoothed resolution of layer s_0 in D^+ or D^- ; the singular resolution of crossing s_0 in D^+ or D^- ; the diagram D^\bullet . Assume the braid axis is to the right of each diagram and all strands are oriented upwards.

Lemma 2.7.1. *Let D^+ and D^- be the diagrams shown in Figure 2.17 and D^\bullet be the diagram on the right in Figure 2.18. Then for any multi-index J , there are isomorphisms of $\widehat{\mathcal{R}}[\underline{x}(D^\bullet)]$ -modules (equivalently $\widehat{\mathcal{R}}[\underline{x}(D^+)]$ - or $\widehat{\mathcal{R}}[\underline{x}(D^-)]$ -modules)*

$$\begin{aligned} \mathcal{A}_J(D^\bullet) &\cong \mathcal{A}_{0J}(D^+) \quad \text{and} \\ \mathcal{A}_J(D^\bullet) &\cong \mathcal{A}_{1J}(D^-). \end{aligned}$$

Proof. Since the $0J$ -resolution of D^+ and the $1J$ -resolution of D^- are identical as diagrams, we will refer to D^+ throughout without loss of generality. The following matrix contains a generating set for \mathcal{L}_0 , the non-local relation associated to the outermost cycle (see Observation 2.2.3), and the non-local relation associated to the set of all vertices except the 4-valent vertex in layer s_0 in $\mathcal{A}_{0J}(D^+)$.

$$\begin{pmatrix} t(x_n + x_2) - (x_0 + x_1) \\ t^2 x_n x_2 - x_0 x_1 \\ t^{\mathbf{w}(D)+b+1} x_n - x_0 \\ t^{\mathbf{w}(D)+b-1} x_1 - x_2 \end{pmatrix} \xrightarrow[\text{II}+t^2 x_n \text{IV}]{\text{I}-\text{III}+t\text{IV}} \begin{pmatrix} (1 - t^{\mathbf{w}(D)+b})(tx_n - x_1) \\ x_1(t^{\mathbf{w}(D)+b+1} x_n - x_0) \\ t^{\mathbf{w}(D)+b+1} x_n - x_0 \\ t^{\mathbf{w}(D)+b-1} x_1 - x_2 \end{pmatrix}$$

Since $1 - t^{\mathbf{w}(D)+b}$ is a unit in $\widehat{\mathcal{R}}$, we can eliminate that factor from the top row. We can eliminate row II because it is a multiple of row III. A bit more simplification leaves exactly the linear relations associated with the arrangement of bivalent vertices and the basepoint on the outermost strand of D^\bullet .

$$\begin{pmatrix} tx_n - x_1 \\ t^{\mathbf{w}(D)+b+1} x_n - x_0 \\ t^{\mathbf{w}(D)+b-1} x_1 - x_2 \end{pmatrix} \xrightarrow[\text{mult. III by } -t]{\text{III}+t^{\mathbf{w}(D)+b-1}\text{I}-t^{-1}\text{II}} \begin{pmatrix} tx_n - x_1 \\ t^{\mathbf{w}(D)+b+1} x_n - x_0 \\ tx_2 - x_0 \end{pmatrix}$$

All other local relations in diagram D^\bullet are exactly the same as those in the $0J$ -resolution of D^+ . For any subset in the $0J$ -resolution of D^+ that does not include the 4-valent vertex in layer s_0 ,

the corresponding subset in the J -resolution of D^\bullet has the same associated non-local relation. Any subset in the $0J$ -resolution of D^+ that does include the 4-valent vertex in layer s_0 has a corresponding subset in the J -resolution of D^\bullet given by the two bivalent vertices nearest to the basepoint and an appropriate subset in the rest of the diagram. These also give the same non-local relation. Therefore, $\mathcal{N}_{0J} \subset \mathcal{N}_J$. By Observation 2.2.1, adjacent bivalent vertices can always be added or removed from a subset without changing the associated non-local relation, so $\mathcal{N}_J \subset \mathcal{N}_{0J}$. This completes the verification that $\mathcal{A}_{0J}(D^+)$ and $\mathcal{A}_J(D^\bullet)$ have identical presentations over the completed edge ring $\widehat{\mathcal{R}}[\underline{x}(D^\bullet)]$. \square

2.8 Identification with knot Floer homology

The set-up of the cube of resolutions in Section 2.1 of this paper differs somewhat from Ozsváth and Szabó's original formulation [45], so it does not follow formally from their work that $C(D)$, as defined in (2.2) of this paper, computes knot Floer homology. However, an adaptation of the arguments in Sections 3–5 of [45], suffices to prove the following result, which is an analogue of [45, Theorem 1.2].

Proposition 2.8.1. *Let D be a layered braid diagram with initial edge x_0 . Then there is an isomorphism of graded $\mathbb{F}_2[x_0]$ -modules*

$$H_*(C(D) \otimes_{\mathcal{R}[\underline{x}(D)]} \widehat{\mathcal{R}[\underline{x}(D)]} \otimes \mathbb{F}_2) \cong HFK^-(K) \otimes_{\mathbb{F}_2} \mathbb{F}_2[t^{-1}, t]$$

and an isomorphism of graded \mathbb{F}_2 -vector spaces

$$H_*(C(D)/(x_0) \otimes_{\mathcal{R}[\underline{x}(D)]} \widehat{\mathcal{R}[\underline{x}(D)]} \otimes \mathbb{F}_2) \cong \widehat{HFK}(K) \otimes_{\mathbb{F}_2} \mathbb{F}_2[t^{-1}, t].$$

The two key differences between our set-up and that of [45] are the use of layered braid diagrams and the ground ring over which we define the cube of resolutions chain complex. Ozsváth and Szabó use a knot projection in braid form with a basepoint $*$, but do not require the additional bivalent vertices that we add parallel to each crossing when forming a layered braid diagram. Consequently, in their diagrams, bivalent vertices arise only when a crossing is smoothed, which means they come in pairs that lie on adjacent strands. A layered braid diagram has these sorts of bivalent vertices, but also others. This difference will require us to modify the Heegaard diagrams used in the proof of [45, Theorem 1.2].

The second difference between our set-up and that of [45] is in the ground rings over which the cube of resolutions complex is defined. We define the algebras $\mathcal{A}_I(D)$ over $\mathcal{R}[\underline{x}(D)] = \mathbb{Z}[t^{-1}, t][\underline{x}(D)]$, and pass to the completion $\widehat{\mathcal{R}} = \mathbb{Z}[t^{-1}, t][\underline{x}(D)]$ for the precise statement of invariance in Section 2.1.4. Ozsváth and Szabó set up their algebras over $\mathbb{F}_2[\underline{x}(D), t]$, pass to the completion

$\mathbb{F}_2[\underline{x}(D)][[t]]$ when identifying these algebras with twisted singular knot Floer homology and finally pass to $\mathbb{F}_2[\underline{x}(D)][t^{-1}, t]$ for the statement of [45, Theorem 1.2]. These choices of rings in each case allow results to be stated in the greatest possible generality, but a profusion of tensor products will be required to bring the two approaches into alignment.

Proof. Ozsváth and Szabó prove [45, Theorem 1.2] in three steps: calculate a particular twisting of singular knot Floer homology to verify that it is identical to the algebra they define as a quotient of the edge ring [45, Section 3]; establish a spectral sequence from the cube of resolutions defined algebraically to knot Floer homology [45, Section 4]; show that the spectral sequence collapses [45, Section 5]. We mirror each of these arguments in turn, pointing out where modifications are required to address the differences between our set-up (Section 2.1 of this paper) and that of [45].

Let S be a layered braid diagram with all crossings singularized or smoothed. The twisted version of singular knot Floer homology needed to recover the algebra $\mathcal{A}(S)$ as defined in (2.1) in Section 2.1.1 of this paper is specified by the “initial diagram” in [45, Figure 3] with the additional rule that near a bivalent vertex that does not arise from smoothing a crossing, the diagram has the form shown on the left in Figure 2.19. Near a pair of bivalent vertices that arise from smoothing a crossing, we use the same diagram as in [45, Figure 3], which is shown in the middle in Figure 2.19. Call this the *modified initial diagram*. Let $\underline{CFK}^-(S)$ denote the chain complex coming from the modified initial diagram. That is, $\underline{CFK}^-(S)$ is the $\mathbb{F}_2[\underline{x}(S)][[t]]$ -module whose generators are given by intersection points and differentials by counting holomorphic disks with respect to the twisting in the modified initial diagram. See [34] for a precise definition of singular knot Floer homology, [45, Section 2.1] for details on twisted coefficients in knot Floer homology generally, and [45, Section 3.1] for details on combining singular knot Floer homology with twisted coefficients. The completion of the ground ring with respect to t is necessary to make the differential on twisted singular knot Floer homology well defined, as detailed in [45, Section 3.1]. We will continue to work over $\mathbb{F}_2[\underline{x}(S)][[t]]$ for the first section of this proof, so abbreviate this ring by \mathcal{R}' .

Let M denote the Koszul complex on the linear relations for each vertex.

$$M = \bigotimes_{v \in V_4} \left(\mathcal{R}' \xrightarrow{tx_a^{(v)} + tx_b^{(v)} - x_c^{(v)} - x_d^{(v)}} \mathcal{R}' \right) \otimes \bigotimes_{v \in V_2} \left(\mathcal{R}' \xrightarrow{tx_a^{(v)} - x_c^{(v)}} \mathcal{R}' \right),$$

where V_4 and V_2 denote the set of 4-valent and bivalent vertices, respectively, in S . Let $C'(S) = \underline{CFK}^-(S) \otimes M$. Then the claim, an analogue of [45, Theorem 3.1], is that we can identify $H_*(C'(S))$ with $\mathcal{A}(S)$ after appropriately changing the ground rings. Recall that $\mathcal{A}(S)$ was defined in (2.1) of Section 2.1.1 of this paper as an $\mathcal{R}[\underline{x}(S)] = \mathbb{Z}[t^{-1}, t][\underline{x}(S)]$ -module. Therefore, the precise claim is that

$$H_*(C'(S)) \otimes_{\mathcal{R}'} \mathcal{R}'[t^{-1}] \cong \mathcal{A}(S) \otimes_{\mathcal{R}[\underline{x}(S)]} \widehat{\mathcal{R}[\underline{x}(S)]} \otimes \mathbb{F}_2. \quad (2.21)$$

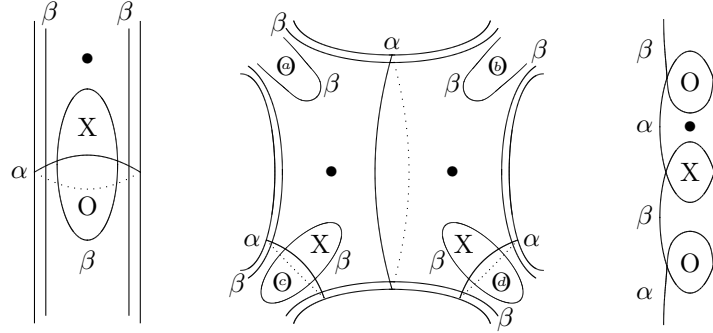

Figure 2.19: From left to right: the modified initial diagram near an extra bivalent vertex; the modified initial diagram near a bivalent vertex arising from a smoothing; the planar diagram or the master diagram near any bivalent vertex. The bold dots in each picture show the marking that specifies our particular twisted version of singular knot Floer homology.

The reduced version of the statement,

$$H_*(C'(S)/(x_0)) \otimes_{\mathcal{R}'} \mathcal{R}'[t^{-1}] \cong \mathcal{A}(S)/(x_0) \otimes_{\mathcal{R}[\underline{x}(S)]} \widehat{\mathcal{R}[\underline{x}(S)]} \otimes \mathbb{F}_2, \quad (2.22)$$

then follows immediately.

The arguments required to prove [45, Proposition 3.4] apply essentially unchanged to show that $H_*(C'(S)/(x_0))$ is free as a $\mathbb{F}_2[[t]]$ -module, generated by the generalized Kauffman states defined in [45, Figure 4], and concentrated in a single algebraic grading. The unreduced $H_*(C'(S))$ is also concentrated in a single algebraic grading. To calculate the structure of $H_*(C'(S))$ as an \mathcal{R}' -module, we use a planar Heegaard diagram for S defined exactly as in [45, Figure 9] with extra bivalent vertices of the layered diagram treated as if they had come from smoothing a crossing. So, the diagram looks like that on the right in Figure 2.19 near any bivalent vertex. The same procedure of handleslides and destabilizations described in the proof of [45, Lemma 3.7] shows that the chain complex specified by this planar diagram is quasi-isomorphic to the one specified by the modified initial diagram. The planar diagram has a canonical generator, which is a cycle, defined by making the same choice of intersection point near each vertex as Ozsváth and Szabó do in [45, Proposition 3.10]. Incoming differentials from chains with algebraic grading one higher than the canonical generator produce all of the quadratic local relations, the linear local relations associated to bivalent vertices, and the non-local relations that appear in the definition of $\mathcal{A}(S)$. Since $H_*(C'(S))$ is concentrated in a single algebraic grading, this completes the calculation and establishes the isomorphisms claimed in (2.21) and (2.22).

Now consider a layered braid diagram D with m crossings, and let D_I denote its I -resolution.

The spectral sequence constructed in [45, Section 4] comes from a filtration on

$$V(D) = \bigoplus_{I \in \{0,1\}^m} H_*(\underline{CFK}^-(D_I) \otimes M_I),$$

where M_I is the Koszul complex on linear relations coming from all vertices in diagram D_I . To define the filtration, Ozsváth and Szabó consider a planar Heegaard diagram that simultaneously encodes each possible state (positive, negative, singularized, smoothed) of a crossing [45, Figure 12]. To adapt this Heegaard diagram to D , we need only add a small piece like that shown on the right in Figure 2.19 near any bivalent vertex. Call the diagram from [45, Figure 12] so adapted the *master diagram*.

Using particular choices of generators near crossings in the master diagram, Ozsváth and Szabó define a filtration on $V(D)$. They also define maps that count holomorphic disks intersecting certain regions near crossings in the master diagram [45, Section 4]. In [45, Proposition 5.2], they verify that some of these maps (those with the appropriate gradings) are the same as the edge maps in Section 2.1.2 of this paper, under the identification of $H_*(C'(D_I))$ with $\mathcal{A}_I(D)$. The description of all of the maps on $V(D)$ and the proof of [45, Proposition 5.2] depend only on the form of their Heegaard diagram near crossings, so they apply unchanged to our master diagram. Taken together, the maps defined by counting appropriate holomorphic disks near crossings in the master diagram form an endomorphism of $V(D)$. Lemma 4.6 of [45] shows that $V(D)$ with this endomorphism is quasi-isomorphic to the chain complex $\underline{CFK}^-(D)$, which is the twisted knot Floer homology of the classical knot D , defined via the traditional holomorphic disks construction and regarded as an $\mathbb{F}_2[x_0][[t]]$ -module. Again, the arguments depend only on the properties of the master diagram near crossings in D , so they carry through unchanged to our situation. Therefore, as in [45, Theorem 4.4], the filtration on $V(D)$ gives rise to a spectral sequence with E_1 page

$$\bigoplus_{I \in \{0,1\}^m} H_*(\underline{CFK}^-(D_I) \otimes M_I),$$

with d_1 differential the zip and unzip maps defined algebraically, and converging to $\underline{HFK}^-(D)$.

Finally, in Section 5, Ozsváth and Szabó argue that this spectral sequence collapses after the E_1 stage for grading reasons. The gradings in this paper are defined identically to those in [45], so the same argument shows that the spectral sequence here collapses. The immediate result is an isomorphism of $\mathbb{F}_2[x_0][[t]]$ -modules

$$H_* \left(\bigoplus_{I \in \{0,1\}^m} H_*(\underline{CFK}^-(D_I) \otimes M_I) \right) \cong H_*(\underline{CFK}^-(D))$$

Inverting t in the ground ring throughout the spectral sequence, then applying the isomorphism from (2.21) allows us to identify the left side with the cube of resolutions complex $C(D)$ used in this

paper:

$$H_* \left(C(D) \otimes_{\mathcal{R}[\underline{x}(D)]} \widehat{\mathcal{R}[\underline{x}(D)]} \otimes \mathbb{F}_2 \right) \cong H_* \left(\underline{CFK}^-(D) \otimes_{\mathbb{F}_2[[t]]} \mathbb{F}_2[t^{-1}, t] \right)$$

A standard theorem about twisted coefficients in knot Floer homology, stated as [45, Lemma 2.2], completes the identification with $H_* (CFK^-(D)) \otimes_{\mathbb{F}_2} \mathbb{F}_2[t^{-1}, t]$. The reduced statement follows similarly. \square

Chapter 3

Braids, Soergel Bimodules, and Knot Floer Homology

This chapter concerns the knot Floer analogue of the braid group action underlying Khovanov's construction of HOMFLY-PT homology in [21]. We begin by naively adapting the knot Floer cube of resolutions from Chapter 2 to braid diagrams instead of closed braid diagrams. Section 3.1 sets up the notation, then proves that this extension makes redundant the ideal of non-local relations. Section 3.2 provides the necessary background on Soergel bimodules and their use in HOMFLY-PT homology. Section 3.3 introduces twisted Soergel bimodules, relates them to the naïve knot Floer braid invariant, and proves that they are only a mild generalization of the original Soergel bimodules. Section 3.4 uses twisted Soergel bimodules to produce a braid group action analogous to the one in HOMFLY-PT homology.

3.1 Knot Floer cube of resolutions for braids

Before bringing Soergel bimodules into the construction, we consider a natural generalization of the knot Floer cube of resolutions from Chapter 2 to braids. Let $\sigma \in \text{Br}_b$ be a braid with b strands and D_σ a layered diagram for σ . As in Chapter 2, a layered diagram is a braid-form projection composed of the three types of layers shown in Figure 3.1. Layered braid diagrams are described by $\text{Br}_b \oplus \mathbb{Z}\langle \lambda \rangle$, where λ refers to the layer with only bivalent vertices. Our convention will be that braids always have the upwards orientation. Label the layers of D_σ by s_0, \dots, s_m as in Chapter 2 and the edges of D_σ by $x_0, \dots, x_{b(m+2)-1} = x_n$, distinguishing between the edges incident to the top and bottom boundaries of the diagram.

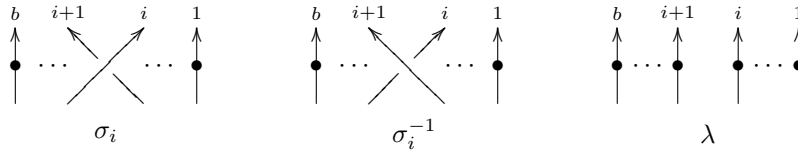

Figure 3.1: Three types of layers in a layered braid diagram and their corresponding generators in $\text{Br}_b \oplus \mathbb{Z}\langle \lambda \rangle$.

Singularizing and smoothing crossings in the same way as in Chapter 2, we obtain a cube of resolutions for the braid diagram D_σ . The diagram at multi-index I is a layered singular braid, which inherits edge labels from D_σ . Figure 3.2 shows a correctly labeled layered singular braid diagram. We will associate to each layered singular braid diagram an algebra defined by combinatorial data from its vertices. The ground ring will be $\widehat{\mathcal{R}} = \mathbb{Z}[t^{-1}, t]$ and the edge ring $\widehat{\mathcal{R}}[x_0, \dots, x_n] = \widehat{\mathcal{R}}[\underline{x}(D_\sigma)]$ as before. To the layered singular braid at multi-index I , associate the algebra

$$\mathcal{A}_I(D_\sigma) = \frac{\widehat{\mathcal{R}}[\underline{x}(D_\sigma)]}{\mathcal{L}_I(D_\sigma) + \mathcal{N}_I(D_\sigma)},$$

where

- $\mathcal{L}_I(D_\sigma)$ is generated by linear relations of the form $tx_a + tx_b - x_c - x_d$ associated to 4-valent vertices and $tx_{i+1} - x_i$ associated to bivalent vertices; and quadratic relations of the form $t^2x_ax_b - x_cx_d$ associated to 4-valent vertices;
- and $\mathcal{N}_I(D_\sigma)$ is generated by non-local relations of the form $g_\Gamma = t^{\mathbf{w}(\Gamma)}x_{\Gamma, D \setminus \Gamma} - x_{D \setminus \Gamma, \Gamma}$ associated to subsets Γ of the vertices in the I -resolution of D_σ .

We write $x_{\Gamma, \Delta}$ for the product of edges from a subset Γ to a subset Δ in a layered singular braid. We will also sometimes write x_Γ^{out} and x_Γ^{in} to refer to $x_{\Gamma, D \setminus \Gamma}$ and $x_{D \setminus \Gamma, \Gamma}$ respectively. For now, we will use the convention that $x_{\Gamma, D \setminus \Gamma}$ includes edges from Γ to the top boundary of the braid and $x_{D \setminus \Gamma, \Gamma}$ includes edges from the bottom boundary of the braid to Γ . As before, the weight $\mathbf{w}(\Gamma)$ is twice the number of 4-valent vertices plus the number of bivalent vertices in Γ . In Chapter 4, we will change notation to emphasize that edges between Γ and other vertices in the layered singular braid sometimes play a different role than edges between Γ and the boundaries of the braid.

The only difference between the algebra $\mathcal{A}_I(D_\sigma)$ associated to a braid and the algebra $\mathcal{A}_I(D_{\widehat{\sigma}})$ associated to its braid closure arises from the different edge labeling in D_σ and $D_{\widehat{\sigma}}$. However, this difference turns out to be quite significant: the non-local relations in a braid diagram are redundant. That is, the generators of $\mathcal{N}_I(D_\sigma)$ are already contained in $\mathcal{L}_I(D_\sigma)$. This is far from the case in the knot Floer cube of resolutions for closed braids. Figure 3.2 illustrates the idea of the proof.

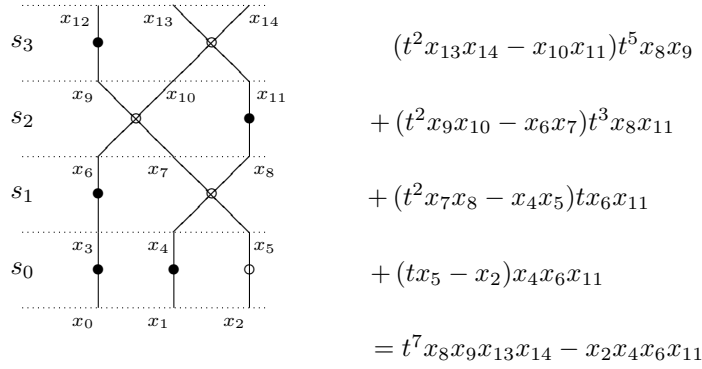

Figure 3.2: At left: A layered singular braid diagram for the 1011-resolution of $\sigma_2 \sigma_1^{-1} \sigma_2 \sigma_1^{-1}$ (reading top to bottom, strands labeled right to left). At right: the bottom line is the non-local relation associated to the subset shown by open dots. The lines above show how it can be obtained from local relations associated to the vertices in the subset. Note that neither x_{14} nor x_2 would appear in the non-local relation associated to this subset in the closure of this diagram.

Proposition 3.1.1. *Let $\sigma \in Br_b$ and D_σ a layered braid diagram for σ . Then*

$$\mathcal{N}_I(D_\sigma) \subset \mathcal{L}_I(D_\sigma)$$

as ideals of the edge ring $\widehat{\mathcal{R}}[\underline{x}(D_\sigma)]$.

Proof. Refer to the notation in Figure 3.3 throughout. Let Γ be a subset of the vertices in the I -resolution of D_σ and let s_j denote the set of vertices in layer j . Filter Γ by layers so that $\Gamma_j = \Gamma \cap (s_j \cup \dots \cup s_m)$ and

$$\emptyset = \Gamma_{m+1} \subset \Gamma_m \subset \dots \subset \Gamma_1 \subset \Gamma_0 = \Gamma.$$

Notice that edges always go from Γ_{k-1} to Γ_k and never in the other direction.

Also, notice that $\Gamma_k \setminus \Gamma_{k+1} = \Gamma \cap s_k$ is a disconnected subset in which each connected component is a single vertex. We established in Observation 2.2.1 that the non-local relations of disconnected subsets are $\widehat{\mathcal{R}}[\underline{x}(D_\sigma)]$ -linear combinations of the non-local relations associated to their connected components. Since the connected components in this case are single vertices, their associated non-local relations are actually the same as their associated local relations. Therefore, it suffices to prove that g_Γ is an $\widehat{\mathcal{R}}[\underline{x}(D_\sigma)]$ -linear combination of the $g_{\Gamma_k \setminus \Gamma_{k+1}}$.

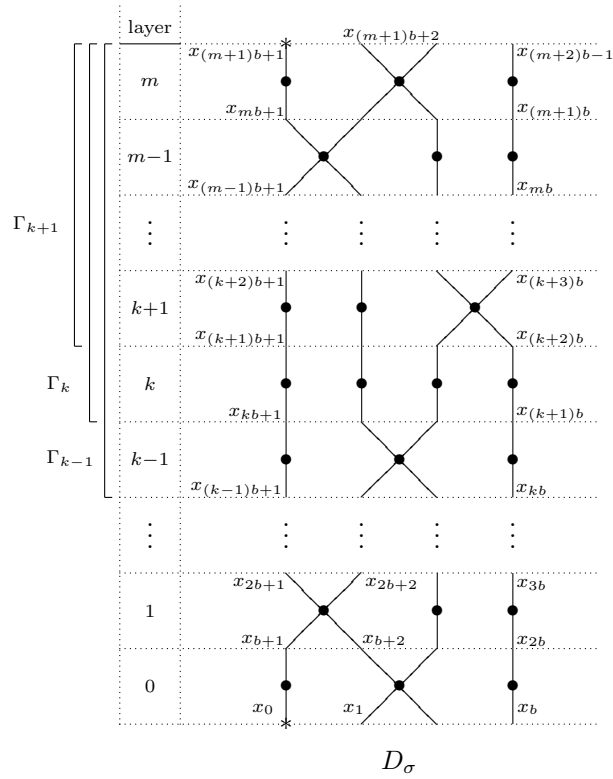

Figure 3.3: Notation for the proof of Proposition 3.1.1.

We claim that g_Γ can be expressed as the sum

$$g_\Gamma = \sum_{j=0}^m t^{\mathbf{w}(\Gamma \setminus \Gamma_j)} x_{D \setminus \Gamma, \Gamma_{j+1}} x_{\Gamma \setminus \Gamma_j, D \setminus \Gamma} g_{\Gamma_j \setminus \Gamma_{j+1}}. \quad (3.1)$$

For convenience, we argue as if Γ intersects all layers of the braid, but the same argument would work with 0 and m replaced by the maximum and minimum layers to which Γ actually extends. To see why Equation (3.1) holds, expand $g_{\Gamma_j \setminus \Gamma_{j+1}}$ and re-index.

$$\begin{aligned} & \sum_{j=0}^m t^{\mathbf{w}(\Gamma \setminus \Gamma_j)} x_{D \setminus \Gamma, \Gamma_{j+1}} x_{\Gamma \setminus \Gamma_j, D \setminus \Gamma} g_{\Gamma_j \setminus \Gamma_{j+1}} \\ &= -t^{\mathbf{w}(\Gamma \setminus \Gamma_0)} x_{\Gamma_0 \setminus \Gamma_1}^{\text{in}} x_{D \setminus \Gamma, \Gamma_1} x_{\Gamma \setminus \Gamma_0, D \setminus \Gamma} \\ &+ \sum_{j=0}^{m-1} \left(t^{\mathbf{w}(\Gamma \setminus \Gamma_j)} t^{\mathbf{w}(\Gamma_j \setminus \Gamma_{j+1})} x_{\Gamma_j \setminus \Gamma_{j+1}}^{\text{out}} x_{D \setminus \Gamma, \Gamma_{j+1}} x_{\Gamma \setminus \Gamma_j, D \setminus \Gamma} \right. \\ &\quad \left. t^{\mathbf{w}(\Gamma \setminus \Gamma_{j+1})} - t^{\mathbf{w}(\Gamma \setminus \Gamma_{j+1})} x_{\Gamma_{j+1} \setminus \Gamma_{j+2}}^{\text{in}} x_{D \setminus \Gamma, \Gamma_{j+2}} x_{\Gamma \setminus \Gamma_{j+1}, D \setminus \Gamma} \right) \\ &+ t^{\mathbf{w}(\Gamma \setminus \Gamma_m)} t^{\mathbf{w}(\Gamma_m \setminus \Gamma_{m+1})} x_{\Gamma_m \setminus \Gamma_{m+1}}^{\text{out}} x_{D \setminus \Gamma, \Gamma_{m+1}} x_{\Gamma \setminus \Gamma_m, D \setminus \Gamma} \end{aligned}$$

The first term simplifies because $\Gamma_0 = \Gamma$ and because the only edges into $\Gamma_0 \setminus \Gamma_1$ are from $D \setminus \Gamma$.

$$t^{\mathbf{w}(\Gamma \setminus \Gamma_0)} x_{\Gamma_0 \setminus \Gamma_1}^{\text{in}} x_{D \setminus \Gamma, \Gamma_1} x_{\Gamma \setminus \Gamma_0, D \setminus \Gamma} = x_{D \setminus \Gamma, \Gamma_0 \setminus \Gamma_1} x_{D \setminus \Gamma, \Gamma_1} = x_{D \setminus \Gamma, \Gamma}$$

The last term simplifies because $\Gamma_{m+1} = \emptyset$ and because Γ_m only has outgoing edges to $D \setminus \Gamma$.

$$t^{\mathbf{w}(\Gamma_m \setminus \Gamma_{m+1})} t^{\mathbf{w}(\Gamma \setminus \Gamma_m)} x_{\Gamma_m \setminus \Gamma_{m+1}}^{\text{out}} x_{D \setminus \Gamma, \Gamma_{m+1}} x_{\Gamma \setminus \Gamma_m, D \setminus \Gamma} = t^{\mathbf{w}(\Gamma)} x_{\Gamma_m, D \setminus \Gamma} x_{\Gamma \setminus \Gamma_m, D \setminus \Gamma} = t^{\mathbf{w}(\Gamma)} x_{\Gamma, D \setminus \Gamma}$$

Note that both of these simplifications rely crucially on the braid diagram *not* being closed. If it were closed, there could be edges from Γ_m to Γ_0 .

The middle two terms in the expanded version of Equation (3.1) cancel. When expanding, the key fact is that edges always go from Γ_{k-1} to Γ_k , never in the opposite direction, and that they never span more than one layer.

$$\begin{aligned} & \sum_{j=0}^{m-1} t^{\mathbf{w}(\Gamma \setminus \Gamma_{j+1})} \left(x_{\Gamma_j \setminus \Gamma_{j+1}, D \setminus \Gamma} x_{\Gamma_j \setminus \Gamma_{j+1}, \Gamma_{j+1} \setminus \Gamma_{j+2}} x_{D \setminus \Gamma, \Gamma_{j+1}} x_{\Gamma \setminus \Gamma_j, D \setminus \Gamma} \right. \\ &\quad \left. - x_{D \setminus \Gamma, \Gamma_{j+1} \setminus \Gamma_{j+2}} x_{\Gamma_j \setminus \Gamma_{j+1}, \Gamma_{j+1} \setminus \Gamma_{j+2}} x_{D \setminus \Gamma, \Gamma_{j+2}} x_{\Gamma \setminus \Gamma_{j+1}, D \setminus \Gamma} \right) \\ & \sum_{j=0}^{m-1} t^{\mathbf{w}(\Gamma \setminus \Gamma_{j+1})} \left(x_{\Gamma_j \setminus \Gamma_{j+1}, D \setminus \Gamma} x_{\Gamma_j \setminus \Gamma_{j+1}, \Gamma_{j+1} \setminus \Gamma_{j+2}} x_{D \setminus \Gamma, \Gamma_{j+2}} x_{D \setminus \Gamma, \Gamma_{j+1} \setminus \Gamma_{j+2}} x_{\Gamma \setminus \Gamma_j, D \setminus \Gamma} \right. \\ &\quad \left. - x_{D \setminus \Gamma, \Gamma_{j+1} \setminus \Gamma_{j+2}} x_{\Gamma_j \setminus \Gamma_{j+1}, \Gamma_{j+1} \setminus \Gamma_{j+2}} x_{D \setminus \Gamma, \Gamma_{j+2}} x_{\Gamma \setminus \Gamma_j, D \setminus \Gamma} x_{\Gamma_j \setminus \Gamma_{j+1}, D \setminus \Gamma} \right) \\ &= 0 \end{aligned} \quad \square$$

Placing $\mathcal{A}_I(D_\sigma)$ at the corners of a cube of resolutions for D_σ and using the same maps and gradings from Sections 2.1.2 and 2.1.3 produces a chain complex that is an invariant of the braid σ . The proofs of braid-like Reidemeister moves II and III for the cube of resolutions of a closed braid carry through to this case with the simplification that non-local relations can now be ignored.

3.2 Soergel bimodules and HOMFLY-PT homology

Throughout this section, the ground field will be \mathbb{Q} . Tensor products are to be taken over \mathbb{Q} unless otherwise specified.

Khovanov’s construction of a homology theory that categorifies the HOMFLY-PT polynomial begins with an assignment of certain bimodules to singular braid diagrams. Given a singular braid diagram with b strands, we define the *strand algebra* to be $\mathcal{S} = \mathbb{Q}[x_1, \dots, x_b]$ with grading given by $\deg(x_i) = 2$ for all i . Let \mathcal{S}_i denote the subring of \mathcal{S} that is invariant under the action of the transposition $(i, i + 1) \in S_b$ permuting the variables of \mathcal{S} , so

$$\mathcal{S}_i = \mathbb{Q}[x_1, \dots, x_{i-1}, x_i + x_{i+1}, x_i x_{i+1}, x_{i+2}, \dots, x_b].$$

To a single singular crossing between strands i and $i + 1$ in a singular braid, we associate the \mathcal{S} -bimodule $B_i = \mathcal{S} \otimes_{\mathcal{S}_i} \mathcal{S}$. Heuristically, the singular crossing makes strands i and $i+1$ indistinguishable in a diagram, so we use the tensor product over \mathcal{S}_i to create a bimodule that does not distinguish between the corresponding strand variables. To join two layers of a singular braid diagram, we tensor the corresponding bimodules over \mathcal{S} with top/bottom in the diagram corresponding to left/right in the tensor product. For example, the singular braid in Figure 3.2 is assigned $B_1 \otimes_{\mathcal{S}} B_2 \otimes_{\mathcal{S}} B_1$. The full subcategory of \mathcal{S} -**grbimod** generated by (finite) tensor products over \mathcal{S} , (finite) direct sums, and grading shifts of the B_i will be denoted **SB**; its objects are called Soergel bimodules [52, 53]. So far, we have defined a map on the objects from the category **SBrCob** $_b$ to **SB**.

The bimodule B_i has the usual action of \mathcal{S} by multiplication on the left and on the right. It inherits a grading from that on \mathcal{S} . As a left or a right \mathcal{S} -module, it is free of rank 2, with generators 1 and x_i

$$B_i \cong \mathcal{S}\langle 1 \rangle \oplus \mathcal{S}\langle x_i \rangle.$$

An \mathcal{S} -bimodule can also be thought of as a left $\mathcal{S} \otimes \mathcal{S}^{\text{op}}$ -module, which is simply an $\mathcal{S} \otimes \mathcal{S}$ -module since \mathcal{S} is commutative in our case. Interpreting B_i in this way reveals its similarity to both the matrix factorizations that appear in Khovanov and Rozansky’s alternate definition of HOMFLY-PT homology [23] and to the knot Floer algebra associated to a layered singular braid diagram with one layer. Specifically, there is a ring isomorphism $\psi : \mathcal{S} \otimes \mathcal{S} \rightarrow \mathbb{Q}[y_1, \dots, y_b, z_1, \dots, z_b]$ defined by

$\psi(x_j \otimes 1) = y_j$ and $\psi(1 \otimes x_j) = z_j$, which induces an isomorphism of $\mathcal{S} \otimes \mathcal{S}$ -modules

$$\psi : B_i \rightarrow \frac{\mathbb{Q}[y_1, \dots, y_b, z_1, \dots, z_b]}{\begin{array}{l} (y_i + y_{i+1}) - (z_i + z_{i+1}), \\ y_i y_{i+1} - z_i z_{i+1}, \\ \{y_j - z_j\}_{j \neq i, i+1} \end{array}} \quad (3.2)$$

by considering the target as an $\mathcal{S} \otimes \mathcal{S}$ -module under base change by ψ . We will call ψ the *edge-strand correspondence*, since it describes how to pass between constructions in which the indeterminates signify edges and those in which the indeterminates signify braid strands. The target module in (3.2) is the homology of the matrix factorization (with the extra variable a set to zero) assigned to a single singular crossing in the alternative definition of HOMFLY-PT homology [23].¹ Khovanov demonstrates in Theorem 1 of [21] that the edge-strand correspondence is compatible with tensoring Soergel bimodules over \mathcal{S} , so that the Soergel bimodule associated to any singular braid diagram is isomorphic to the homology of the matrix factorization (with the extraneous variable a set to zero) associated to the same diagram. The quotient of $\mathbb{Q}[y_1, \dots, y_b, z_1, \dots, z_b]$ in (3.2) also bears interesting similarities to the knot Floer algebras. Naïvely, it looks like the quotient of the knot Floer edge ring by the local relations associated to a single singular crossing, with the parameter t set to 1. Of course, since the knot Floer algebras are defined over a Laurent series ring in t (in which $t - 1$ is a unit), setting t to 1 is not so interesting. Section 3.3 takes a less naïve approach to exploring this similarity.

The key property of Soergel bimodules for our purposes is that they satisfy categorified statements of the relations governing the Murakami-Ohtsuki-Yamada graph polynomial's behavior on singular braid diagrams. Equivalently, they satisfy categorified statements of the Hecke algebra's defining relations.

Proposition 3.2.1 ([52]). *Let B_i denote the Soergel bimodule $\mathcal{S} \otimes_{\mathcal{S}_i} \mathcal{S}$ as defined above and $\mathcal{B}_i = B_i[-1]$. Then the following isomorphisms of graded \mathcal{S} -bimodules hold, where all tensor products are taken over \mathcal{S} .*

1. $\mathcal{B}_i \otimes \mathcal{B}_i \cong \mathcal{B}_i[-1] \oplus \mathcal{B}_i[1]$
2. $(\mathcal{B}_i \otimes \mathcal{B}_{i+1} \otimes \mathcal{B}_i) \oplus \mathcal{B}_{i+1} \cong (\mathcal{B}_{i+1} \otimes \mathcal{B}_i \otimes \mathcal{B}_{i+1}) \oplus \mathcal{B}_i$
3. $\mathcal{B}_i \otimes \mathcal{B}_j \cong \mathcal{B}_j \otimes \mathcal{B}_i$ if $|i - j| > 1$.

Murakami, Ohtsuki, and Yamada [30] define a polynomial on weighted trivalent graphs that extends to the HOMFLY-PT polynomial via the singular skein relations

$$P(\text{X}) = P(\text{X}) + qP(\text{X}) \quad \text{and} \quad P(\text{X}) = P(\text{X}) + qP(\text{X}). \quad (3.3)$$

¹ Matrix factorizations in general are not chain complexes, but those in [23] become chain complexes when the extra parameter a is set to zero.

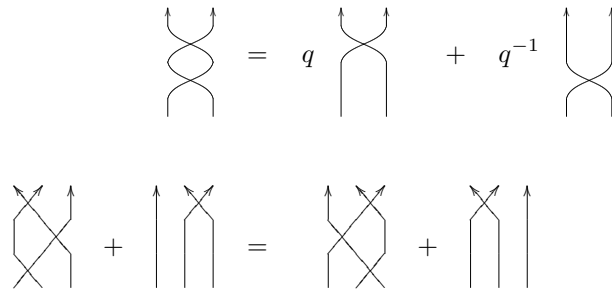

Figure 3.4: Murakami-Ohtsuki-Yamada relations for singular braids with unweighted edges.

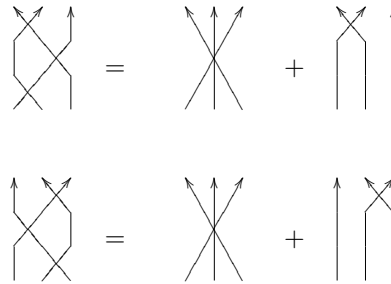

Figure 3.5: Extended Murakami-Ohtsuki-Yamada relations with six-valent vertex.

The polynomial for a graph is calculated via simplifying relations. Figure 3.4 shows the limited set of relations that are relevant to calculations with singular braid diagrams. Replacing each singular braid diagram with its corresponding Soergel bimodule, the symbol $+$ with \oplus , and each appearance of q^k with a grading shift of $[k]$ yields categorified statements of the Murakami-Ohtsuki-Yamada relations, which are exactly the statements in Proposition 3.2.1.²

We may simplify statement (2) in Proposition 3.2.1 by noticing that $\mathcal{B}_i \otimes \mathcal{B}_{i+1} \otimes \mathcal{B}_i$ and $\mathcal{B}_{i+1} \otimes \mathcal{B}_i \otimes \mathcal{B}_{i+1}$ actually contain a common summand $\mathcal{B}_{i,i+1} := \mathcal{S} \otimes_{\mathcal{S}_{i,i+1}} \mathcal{S}[-3]$, where $\mathcal{S}_{i,i+1}$ is the subring of \mathcal{S} invariant under the action of S_3 by permutations of x_i, x_{i+1} , and x_{i+2} . Using the same heuristic as above, this summand is appropriately represented by a six-valent vertex at which strands $i, i+1$, and $i+2$ become indistinguishable. Figure 3.5 shows how the Murakami-Ohtsuki-Yamada relations can be rewritten to reflect this change.

If we associate a generator g_i to a singular crossing between strands i and $i+1$, then the Murakami-Ohtsuki-Yamada relations shown in Figure 3.4 become exactly the relations among the

² The diagrammatic interpretation of the third statement of Proposition 3.2.1 is simply that the Murakami-Ohtsuki-Yamada graph polynomial is well defined on isotopy classes of braid diagrams.

g_i in the following presentation of the Hecke algebra.

$$\begin{aligned} H(b, q) = \langle g_1, \dots, g_{b-1} \mid & g_i^2 = (q + q^{-1})g_i, \\ & g_i g_{i+1} g_i + g_{i+1} = g_{i+1} g_i g_{i+1} + g_i, \\ & g_i g_j = g_j g_i \text{ if } |i - j| > 1 \rangle \end{aligned}$$

Replacing each g_i with the Soergel bimodule \mathcal{B}_i , replacing $+$ with \oplus , and q^k with $[k]$ as before yields categorified Hecke algebra relations as stated in Proposition 3.2.1.

In fact, Soergel proved a much stronger (and more difficult) result. Enlarging the category \mathbf{SB} to include all direct summands of its objects (i.e. taking the Karoubi envelope $\text{Kar}(\mathbf{SB})$) produces a category whose split Grothendieck ring is isomorphic to the Hecke algebra.

Theorem 3.2.1 (Soergel [52, 53]). *Let $\text{Kar}(\mathbf{SB})$ denote the Karoubi envelope of the category \mathbf{SB} of Soergel bimodules. Let K_0 denote the split Grothendieck group and $H(b, q)$ the Hecke algebra with $b - 1$ generators over $\mathbb{Z}[q^{-1}, q]$. Then there is a ring isomorphism*

$$\Phi : H(b, q) \longrightarrow K_0(\text{Kar}(\mathbf{SB}))$$

taking 1 to $[\mathcal{S}]$ and g_i to $[\mathcal{B}_i]$ for each i .

To produce the functor $\widehat{\mathcal{F}}_{\text{HOMFLY-PT}}^b$ promised in Chapter 1, one should define maps between Soergel bimodules for each basic foam between trivalent graphs and prove that they satisfy certain relations. This has been worked out in detail for the \mathfrak{sl}_n homologies [28] and is expected to hold for HOMFLY-PT homology as well. It is currently work in progress by Blanchet [3].

To extend from the functor $\widehat{\mathcal{F}}_{\text{HOMFLY-PT}}^b$ on singular braids to $\mathcal{F}_{\text{HOMFLY-PT}}^b$ on braids, we must pass to the homotopy category of complexes of Soergel bimodules $\text{Com}(\mathbf{SB})$. On objects, $\mathcal{F}_{\text{HOMFLY-PT}}^b$ is defined from a braid group action introduced by Rouquier [50]. To a single positive crossing σ_i between strands i and $i + 1$, Rouquier assigns the complex

$$F(\sigma_i) : 0 \rightarrow B_i[-2] \xrightarrow{1} \mathcal{S}[-2] \rightarrow 0,$$

where 1 denotes the map $1 \otimes 1 \mapsto 1$, extended to be an \mathcal{S} -bimodule map. To a single negative crossing σ_i^{-1} , he assigns the complex

$$F(\sigma_i^{-1}) : 0 \rightarrow \mathcal{S}[2] \xrightarrow{(x_i - x_{i+1}) \otimes 1 + 1 \otimes (x_i - x_{i+1})} B_i \rightarrow 0,$$

where $(x_i - x_{i+1}) \otimes 1 + 1 \otimes (x_i - x_{i+1})$ denotes the map taking $1 \in \mathcal{S}$ to the designated element of B_i , extended to be an \mathcal{S} -bimodule map. With grading shifts as noted, these maps are homogenous with respect to the grading on \mathcal{S} . Define a cohomological grading by placing B_i in cohomological degree

0 in both complexes. To join crossings in a braid diagram, tensor the associated complexes over \mathcal{S} with top/bottom in the diagram corresponding to left/right in the tensor product. For example, assign to the braid $\sigma_2^{-1}\sigma_1\sigma_2^{-1}\sigma_1$, the complex

$$F(\sigma_2^{-1}\sigma_1\sigma_2^{-1}\sigma_1) = F(\sigma_2^{-1}) \otimes_{\mathcal{S}} F(\sigma_1) \otimes_{\mathcal{S}} F(\sigma_2^{-1}) \otimes_{\mathcal{S}} F(\sigma_1)$$

The result is a bigraded complex $F(\sigma)$ defined for each braid word σ .

In the interest of comparing to the knot Floer cube of resolutions construction, we note that the complexes $F(\sigma)$ can be defined by performing the above procedures in a slightly different order. First, form a cube of resolutions from a braid diagram by singularizing or smoothing each crossing and indexing the resolutions using the conventions in Figure 2.2. To the singular braid diagrams at the corners of the cube, associate the Soergel bimodule specified by $\widehat{\mathcal{F}}_{\text{HOMFLY-PT}}^b$. Denote the \mathcal{S} -bimodule associated to the I -resolution of a diagram D_σ by $B_I(D_\sigma)$. To an edge of the cube where a crossing changes from singular to smooth (resp. smooth to singular), associate the map from $F(\sigma_i)$ (resp. $F(\sigma_i^{-1})$). The result is the Rouquier complex for the original braid diagram. Both of these constructions—applying $\widehat{\mathcal{F}}_{\text{HOMFLY-PT}}^b$ to a diagrammatic cube of resolutions or tensoring complexes $F(\sigma_i)$ —are compatible with the edge-strand correspondence [23, Theorem 1], so $F(\sigma)$ is also the homology of the matrix factorization associated to σ in [23], again with the matrix factorization’s extra parameter a set to zero.

Rouquier [50] proves that the complexes $F(\sigma)$ define a genuine action (in the terminology of [25]) of the braid group on $\text{Com}(\mathbf{SB})$. This means that $-\otimes F(\sigma)$ is an invertible endofunctor on $\text{Com}(\mathbf{SB})$; that for any $\sigma, \sigma' \in \text{Br}_b$, the complex $F_{\sigma\sigma'}$ is homotopy equivalent to $F_\sigma \otimes F_{\sigma'}$; and that these homotopy equivalences satisfy the associativity property in the following commutative diagram.

$$\begin{array}{ccc} F(\sigma) \otimes F(\sigma') \otimes F(\sigma'') & \xrightarrow{\cong} & F(\sigma\sigma') \otimes F(\sigma'') \\ \downarrow \cong & & \downarrow \cong \\ F(\sigma) \otimes F(\sigma'\sigma'') & \xrightarrow{\cong} & F(\sigma\sigma'\sigma'') \end{array}$$

Checking that these complexes define a weak braid group action amounts to checking that they are invariant up to homotopy under braid-like Reidemeister moves applied to the braid diagram. This can be done explicitly, as in [23]. The fact that the braid group action is genuine follows by passing to the derived category, where the action collapses to an action of the symmetric group that is more evidently genuine [50, Section 3.3]. Khovanov and Seidel later showed that Rouquier’s braid group action is faithful [24].

So far, we have defined $\mathcal{F}_{\text{HOMFLY-PT}}^b$ on the objects of \mathbf{BrCob}_b by sending a braid diagram σ to the complex $F(\sigma)$. Khovanov and Thomas [25] define maps between Rouquier complexes that

correspond to the basic braid movies from which any morphism in \mathbf{BrCob}_b can be obtained. They prove that their assignments are well-defined up to a sign, making

$$\mathcal{F}_{\text{HOMFLY-PT}}^b : \mathbf{BrCob}_b \longrightarrow \text{Com}(\mathbf{SB})$$

a projective functor. The sign ambiguities are resolved in [9], so $\mathcal{F}_{\text{HOMFLY-PT}}^b$ is in fact a functor from \mathbf{BrCob}_b to $\text{Com}(\mathbf{SB})$.

3.3 Twisted Soergel bimodules

Throughout this section, the ground field will be $\mathbb{Q}[t^{-1}, t]$. Tensor products are to be taken over $\mathbb{Q}[t^{-1}, t]$ unless otherwise specified.

3.3.1 Overview

The edge-strand correspondence introduced in the previous section establishes some similarities between Soergel bimodules and the knot Floer algebras associated to singular braids in the Ozsváth-Szabó cube of resolutions construction. In particular, the local relations of the knot Floer construction are very nearly the relations that appear when the edge-strand correspondence is used to interpret a Soergel bimodule as a module over the edge ring. The goal of this section is to modify the category of Soergel bimodules so that this near similarity can be formalized. In so doing, we tackle the first two parts of the model advocated in Chapter 1: an assignment of something like Soergel bimodules to singular braids and a braid group action on complexes of these modified Soergel bimodules. The braid invariant that we produce in this section is simultaneously a natural extension of the knot Floer algebras to braids and a minor modification of the braid invariant from Rouquier complexes.

We will first define a category \mathbf{SB}^τ of *twisted Soergel bimodules* by enlarging the ground field of the strand algebra and changing the way the strand algebra acts on one side of a Soergel bimodule. We then assign twisted Soergel bimodules to layered singular braid diagrams (as defined in Chapter 2). Under the edge-strand correspondence, the twisted Soergel bimodule associated to a layered singular braid diagram will be the knot Floer algebra associated to the same diagram in Section 3.1. We will detail this construction for a non-closed braid and prove the following proposition in Section 3.3.2.

Proposition 3.3.1. *Let D_σ be a layered braid diagram of the braid σ and $B_I^\tau(D_\sigma)$ be the twisted Soergel bimodule associated to its I -resolution. Let $\mathcal{E}(D_\sigma)$ be the edge ring of D_σ . Then under base change via the edge-strand correspondence there is an isomorphism of $\mathcal{E}(D_\sigma)$ -modules*

$$B_I^\tau(D_\sigma) \cong \mathcal{A}_I(D_\sigma).$$

Twisted Soergel bimodules will satisfy analogous decomposition properties to the usual Soergel bimodules. We will interpret these as categorifications of layered versions of the Murakami-Ohtsuki-Yamada relations.

The category of twisted Soergel bimodules will turn out to be only a mild generalization of the original category of Soergel bimodules. Its split Grothendieck group will categorify the Hecke algebra with an extra indeterminate and its inverse adjoined. We will prove the following proposition in Section 3.3.3.

Proposition (Proposition 3.3.5). *Let \mathbf{SB}^τ denote the category of twisted Soergel bimodules and $\text{Kar}(\mathbf{SB}^\tau)$ its Karoubi envelope. Let K_0 denote the split Grothendieck group and $H(b, q)$ the Hecke algebra with $b - 1$ generators over $\mathbb{Z}[q^{-1}, q]$. Then there is a ring isomorphism*

$$\Phi^\tau : H(b, q) \otimes_{\mathbb{Z}} \mathbb{Z}[\ell, \ell^{-1}] \longrightarrow K_0(\text{Kar}(\mathbf{SB}^\tau)).$$

The remainder of the HOMFLY-PT homology construction described in Section 3.2 can be carried out in the context of twisted Soergel bimodules with minimal changes. In Section 3.4, we will define twisted Rouquier complexes and produce a braid group action on $\text{Com}(\mathbf{SB}^\tau)$.

Proposition 3.3.2. *Rouquier complexes of twisted Soergel bimodules define a braid group action on $\text{Com}(\mathbf{SB}^\tau)$.*

3.3.2 Definition and basic properties

If M is a bimodule over an algebra A and $\varphi : A \rightarrow A$ is an endomorphism, then we define M^φ to be the bimodule in which the left action is the same as for M while the right action is twisted by φ . That is, for $a \in A$ and $m \in M$, we have $a \cdot m = am$ and $m \cdot a = m\varphi(a)$. For any A -bimodule M , $M \otimes_A A^\varphi$ is canonically M^φ . In the case of A as a bimodule over itself, this means that twisting is compatible with tensor product: if φ and ψ are endomorphisms of A , then there is a canonical isomorphism of A -bimodules $A^\varphi \otimes_A A^\psi \cong A^{\varphi\psi}$. Since tensor product distributes over direct sum, we have compatibility of twisting with direct sum as well: $(M \oplus N)^\varphi \cong (M \oplus N) \otimes_A A^\varphi \cong (M \otimes_A A^\varphi) \oplus (N \otimes_A A^\varphi) \cong M^\varphi \oplus N^\varphi$ for A -bimodules M and N . There is also a bimodule ${}^\varphi M$ in which the left action is twisted by φ and the right action is as usual. If φ is invertible, then there is an isomorphism of A -bimodules ${}^\varphi A \cong A^{\varphi^{-1}}$.

We will define the category of twisted Soergel bimodules as a subcategory of $\mathbb{Q}[t^{-1}, t][x_1, \dots, x_b]$ -**rbimod**, where $\mathbb{Q}[t^{-1}, t]$ is in grading zero and each x_i is in grading 2. The new strand algebra $\mathbb{Q}[t^{-1}, t][x_1, \dots, x_b]$ (which we will abbreviate $\mathbb{Q}[t^{-1}, t][\underline{x}]$ when b is unimportant or clear from context) is a base change of the strand algebra from Section 3.2 that replaces the ground ring \mathbb{Q} with

the ring of Laurent series over \mathbb{Q} . We choose to work over \mathbb{Q} rather than \mathbb{Z} (and $\mathbb{Q}[t^{-1}, t]$ rather than $\mathbb{Q}[t^{-1}, t]$) at this juncture because certain results about categories of Soergel bimodules are known only over infinite fields with characteristic $\neq 2$ (though expected to hold in more generality). The completion from Laurent polynomials to Laurent series is also required for Lemma 2.7.1 in the proof of invariance for the knot Floer cube of resolutions in Chapter 2, and for the interpretation of the knot Floer algebras as singular knot Floer homology with twisted coefficients using the holomorphic disks and Heegaard diagrams definitions of [34] (see Proposition 2.8.1). Working over a field also makes various homological algebra arguments easier, of course. We will keep $\mathbb{Q}[t^{-1}, t]$ as the ground field for the remainder of this section, so we will abuse notation by re-defining $\mathcal{S} = \mathbb{Q}[t^{-1}, t][x_1, \dots, x_b]$ to be the strand algebra and $B_i = \mathcal{S} \otimes_{\mathcal{S}_i} \mathcal{S}$ to be the basic Soergel bimodules for $1 \leq i \leq b - 1$. When we want to differentiate between categories of Soergel bimodules over different ground fields, we will write $\mathbf{SB}^{\mathbb{Q}}$ or $\mathbf{SB}^{\mathbb{Q}[t^{-1}, t]}$.

We will consider Soergel bimodules twisted by the $\mathbb{Q}[t^{-1}, t][\underline{x}]$ -algebra automorphism

$$\tau : \mathbb{Q}[t^{-1}, t][\underline{x}] \rightarrow \mathbb{Q}[t^{-1}, t][\underline{x}]$$

defined by $\tau(x_i) = tx_i$ for all i . Define the i^{th} twisted Soergel bimodule to be $B_i^\tau = (\mathcal{S} \otimes_{\mathcal{S}_i} \mathcal{S})^\tau$. Equivalently, we could write B_i^τ as $B_i \otimes_{\mathcal{S}} \mathcal{S}^\tau$, where \mathcal{S}^τ is the twisting of the strand algebra as a bimodule over itself, since

$$B_i \otimes_{\mathcal{S}} \mathcal{S}^\tau = (\mathcal{S} \otimes_{\mathcal{S}_i} \mathcal{S}) \otimes_{\mathcal{S}} \mathcal{S}^\tau \cong (\mathcal{S} \otimes_{\mathcal{S}_i} \mathcal{S})^\tau = B_i^\tau.$$

Note that τ is invertible, so we also have $\mathcal{S}^{\tau^{-1}} \cong \tau\mathcal{S}$ and $\tau\mathcal{S} \otimes_{\mathcal{S}} \mathcal{S}^\tau \cong \mathcal{S}^\tau \otimes_{\mathcal{S}} \tau\mathcal{S} \cong \mathcal{S}$. We use the same grading on twisted Soergel bimodules as before, with $\mathbb{Q}[t^{-1}, t]$ in grading 0 and x_i in grading 2 for all i . As was the case for usual Soergel bimodules, twisted Soergel bimodules are free and rank two as left modules and as right modules over \mathcal{S} . However, twisted bimodules are not in general isomorphic to their untwisted counterparts—far from it in this case.

Proposition 3.3.3. *Let M and N be \mathcal{S} -bimodules and τ the automorphism of \mathcal{S} described above. Then*

$$\text{Hom}(M^\tau, N^\tau) \cong \text{Hom}(M, N)^\tau$$

as \mathcal{S} -bimodules. Moreover, if B and \overline{B} are objects in $\mathbf{SB}^{\mathbb{Q}[t^{-1}, t]}$. Then

$$\text{Hom}(B^{\tau^i}, \overline{B}^{\tau^j}) = 0$$

whenever $i \neq j$.

Proof. For the first statement, observe first that the morphisms between two objects in \mathcal{S} -**grbimod** themselves form an \mathcal{S} -bimodule. Suppose that $f \in \text{Hom}(M, N)$. Since f is a morphism of left

\mathcal{S} -modules and of right \mathcal{S} -modules, we have for any $m \in M$

$$f(x_i \cdot m) = x_i \cdot f(m) = (x_i \cdot f)(m) \text{ and } f(m \cdot x_i) = f(m) \cdot x_i = (f \cdot x_i)(m).$$

But the same requirements apply if $f \in \text{Hom}(M^\tau, N^\tau)$ or $f \in \text{Hom}(M, N)^\tau$; only the meaning of \cdot changes. In other words, the action of \mathcal{S} on M and N must be compatible with its action on $\text{Hom}(M, N)$. For example, if $f(m \cdot x_i) = f(mt x_i)$, then we must have $(f \cdot x_i)(m) = f(m) t x_i$. Therefore the \mathcal{S} -bimodule isomorphism between $\text{Hom}(M^\tau, N^\tau)$ and $\text{Hom}(M, N)^\tau$ simply sends $f \in \text{Hom}(M^\tau, N^\tau)$ to f and we have checked that this identification is compatible with the actions of \mathcal{S} on both sides.

For the second statement, consider the left and right actions of the product $x_1 \cdots x_b$ on elements of B and \overline{B} . Both bimodules are made from direct sums and tensor products of \mathcal{S} over subrings of \mathcal{S} invariant under various transpositions in S_n . Since $x_1 \cdots x_b$ is invariant under the action of S_n on \mathcal{S} by permuting variables, it is certainly invariant under any transposition. Therefore, it can move across any of the tensor products that appear in B or \overline{B} :

$$(x_1 \cdots x_b) \cdot m = (x_1 \cdots x_b)m = m(x_1 \cdots x_b) = m \cdot (x_1 \cdots x_b)$$

if $m \in B$ or $m \in \overline{B}$. The twisted bimodules are related to the untwisted bimodules by $B^{\tau^i} = B \otimes_{\mathcal{S}} \mathcal{S}^{\tau^i}$ and $\overline{B}^{\tau^j} = \overline{B} \otimes_{\mathcal{S}} \mathcal{S}^{\tau^j}$, so $x_1 \cdots x_b$ can still be moved across any tensor product that appears in B^{τ^i} or \overline{B}^{τ^j} . The left and right actions are then related by

$$\begin{aligned} m \cdot (x_1 \cdots x_b) &= m t^{bi} x_1 \cdots x_b = t^{bi} x_1 \cdots x_b m = (t^{bi} x_1 \cdots x_b) \cdot m \text{ in } B^{\tau^i} \text{ and} \\ m \cdot (x_1 \cdots x_b) &= m t^{bj} x_1 \cdots x_b = t^{bj} x_1 \cdots x_b m = (t^{bj} x_1 \cdots x_b) \cdot m \text{ in } \overline{B}^{\tau^j}. \end{aligned}$$

Now suppose that $m \in B^{\tau^i}$ and f is a bimodule morphism from B^{τ^i} to \overline{B}^{τ^j} . Then on the one hand, if we use the fact that f is a bimodule morphism to compute in B^{τ^i} , then we have

$$\begin{aligned} f(m) \cdot (x_1 \cdots x_b) &= f(m \cdot (x_1 \cdots x_b)) \\ &= f((t^{bi} x_1 \cdots x_b) \cdot m) \\ &= (t^{bi} x_1 \cdots x_b) \cdot f(m). \end{aligned}$$

On the other hand, computing in \overline{B}^{τ^j} gives

$$f(m) \cdot (x_1 \cdots x_b) = (t^{bj} x_1 \cdots x_b) \cdot f(m).$$

Therefore, for any $m \in B^{\tau^i}$ and any bimodule morphism f we must have

$$(t^{bi} - t^{bj})(x_1 \cdots x_b) f(m) = 0$$

in \overline{B}^{τ^j} . Since $t^{bi} - t^{bj}$ is a unit in the ground field $\mathbb{Q}[t^{-1}, t]$ and \overline{B}^{τ^j} is free as a left \mathcal{S} -module, this means that $f(m) = 0$. \square

We assign twisted Soergel bimodules to layered singular braid diagrams. These are vertical stacks of the two diagrams that can be obtained by singularizing or smoothing the layers shown in Figure 3.1: the singularization of diagrams σ_i or σ_i^{-1} or the diagram λ . To the diagram λ , we associate \mathcal{S}^τ . To a singular crossing between strands i and $i + 1$, we associate B_i^τ . In keeping with the heuristic from the previous section, these assignments recognize that strands i and $i + 1$, hence strand variables x_i and x_{i+1} become indistinguishable at a singular crossing. The twisting also records the orientation of the layered singular braid. Passing through a layer (either a bivalent vertex or a 4-valent vertex) in a diagram corresponds to passing from the right action to the left action of a strand variable on $B_i^\tau = (\mathcal{S} \otimes_{\mathcal{S}_i} \mathcal{S})^\tau$, which differ by a factor of t . To stack layers of a singular braid, we tensor the corresponding twisted Soergel bimodules over \mathcal{S} with top/bottom in the diagram corresponding to left/right in the tensor product. Since twisting is compatible with tensor products, the twisted Soergel bimodule associated to a layered singular braid diagram with m layers is the usual Soergel bimodule associated to the same diagram, twisted by τ^m . For example, the twisted Soergel bimodule associated to the layered singular braid in Figure 3.2 is

$$B_1^\tau \otimes_{\mathcal{S}} B_2^\tau \otimes_{\mathcal{S}} B_1^\tau \otimes_{\mathcal{S}} \mathcal{S}^\tau \cong (B_1 \otimes_{\mathcal{S}} B_2 \otimes_{\mathcal{S}} B_1)^\tau{}^4.$$

The analogue of the edge-strand correspondence in the twisted setting establishes the close relationship between the twisted Soergel bimodule B_i^τ and the knot Floer algebra assigned to the layered singular braid with one singular crossing between strands i and $i + 1$ of a braid. The edge ring for a single layer is $\mathbb{Q}[t^{-1}, t][y_1, \dots, y_b, z_1, \dots, z_b]$, with outgoing edges labeled y_1, \dots, y_b from right to left and incoming edge labeled z_1, \dots, z_b from right to left. Interpreting the strand algebra $\mathcal{S} = \mathbb{Q}[t^{-1}, t][x_1, \dots, x_b]$ as a left $\mathcal{S} \otimes \mathcal{S}$ -module, there is a ring isomorphism

$$\psi : \mathcal{S} \otimes \mathcal{S} \rightarrow \mathbb{Q}[t^{-1}, t][y_1, \dots, y_b, z_1, \dots, z_b]$$

given by $\psi(1 \otimes 1) = 1$, $\psi(x_j \cdot (1 \otimes 1)) = \psi(x_j \otimes 1) = y_j$ and $\psi((1 \otimes 1) \cdot x_j) = \psi(1 \otimes tx_j) = z_j$. Considering the knot Floer algebra as an $\mathcal{S} \otimes \mathcal{S}$ -module under base change via ψ gives the isomorphism of $\mathcal{S} \otimes \mathcal{S}$ -modules

$$\psi : B_i^\tau \rightarrow \frac{\mathbb{Q}[t^{-1}, t][y_1, \dots, y_b, z_1, \dots, z_b]}{t^{(y_i + y_{i+1}) - (z_i + z_{i+1})}, t^2 y_i y_{i+1} - z_i z_{i+1}, \{t y_j - z_j\}_{j \neq i, i+1}}, \quad (3.4)$$

which we again refer to as the edge-strand correspondence. The edge-strand correspondence is

clearer if we describe B_i^τ as a quotient of $(\mathcal{S} \otimes_{\mathbb{Q}[t^{-1}, t]} \mathcal{S})^\tau$.

$$B_i^\tau = \frac{(\mathcal{S} \otimes_{\mathbb{Q}[t^{-1}, t]} \mathcal{S})^\tau}{\begin{array}{l} t(x_i + x_{i+1}) \cdot (1 \otimes 1) - (1 \otimes 1) \cdot (x_i + x_{i+1}), \\ t^2 x_i x_{i+1} \cdot (1 \otimes 1) - (1 \otimes 1) \cdot x_i x_{i+1}, \\ \{t x_j \cdot (1 \otimes 1) - (1 \otimes 1) \cdot x_j\}_{j \neq i, i+1} \end{array}}$$

We may now prove Proposition 3.3.1.

Proof of Proposition 3.3.1. Let D be the layered braid diagram with one layer and a crossing (of either type) between strands i and $i + 1$. The module on the right in (3.4) is the quotient of the edge ring of D by the local relations in the singular resolution of that braid, although with different edge labels than in Section 3.1.

The isomorphism ψ is compatible with tensor products. That is, if D_σ is a layered braid diagram and $B_I^\tau(D_\sigma)$ is the twisted Soergel bimodule associated to its I -resolution, then

$$B_I^\tau(D_\sigma) \cong \frac{\mathcal{E}(D_\sigma)}{\mathcal{L}_I(D_\sigma)}.$$

By Proposition 3.1.1, $\mathcal{N}(D_\sigma) \subset \mathcal{L}_I(D_\sigma)$, so

$$\frac{\mathcal{E}(D_\sigma)}{\mathcal{L}_I(D_\sigma)} \cong \frac{\mathcal{E}(D_\sigma)}{\mathcal{L}_I(D_\sigma) + \mathcal{N}_I(D_\sigma)} = \mathcal{A}_I(D_\sigma)$$

□

Grading conventions differ in HOMFLY-PT homology and knot Floer homology, but the (Alexander) grading on the knot Floer algebras for layered singular braids and the grading on Soergel bimodules can each be recovered from the other. The knot Floer convention for the edge ring, which we will call \deg_{HFk} puts $\mathbb{Q}[t^{-1}, t]$ in grading 0 and $\deg_{\text{HFk}}(x_i) = -1$ for each i . The Alexander grading on a singular knot Floer algebra is the symmetrization of this grading $A_I = \deg_{\text{HFk}} + \frac{1}{2}(\sigma - b + 1)$, where I is a multi-index denoting a resolution of a layered singular braid, σ is the number of singular crossings in the diagram, and b is the number of braid strands. The HOMFLY-PT grading convention on the strand algebra, which we will call \deg_{SB} , puts $\mathbb{Q}[t^{-1}, t]$ in grading 0 and $\deg_{\text{SB}}(x_i) = 2$. We have used the HOMFLY-PT conventions for twisted Soergel bimodules. To recover the Alexander grading on the twisted Soergel bimodule assigned to the I -resolution of a layered braid, simply compute

$$A_I = -\frac{1}{2} \deg_{\text{SB}} + \frac{1}{2}(\sigma - b + 1).$$

A dictionary of grading conventions is provided in Table 3.1 at the end of this chapter.

It follows either from the edge-strand correspondence and Lemmas 2.4.1, 2.6.1, and 2.6.2 for knot Floer algebras in Chapter 2 or from the compatibility of twisting with tensor products and direct sums of bimodules that twisted Soergel bimodules satisfy decomposition properties analogous to those of usual Soergel bimodules.

Proposition 3.3.4. *Let $\mathcal{B}_i^\tau = B_i^\tau[-1]$. Then there are isomorphisms of \mathcal{S} -bimodules as follows, where all tensor products are taken over \mathcal{S} .*

1. $\mathcal{B}_i^\tau \otimes \mathcal{B}_i^\tau \cong \mathcal{B}_i^{\tau^2}[-1] \oplus \mathcal{B}_i^{\tau^2}[1]$
2. $(\mathcal{B}_i^\tau \otimes \mathcal{B}_{i+1}^\tau \otimes \mathcal{B}_i^\tau) \oplus \mathcal{B}_{i+1}^{\tau^3} \cong (\mathcal{B}_{i+1}^\tau \otimes \mathcal{B}_i^\tau \otimes \mathcal{B}_{i+1}^\tau) \oplus \mathcal{B}_i^{\tau^3}$
3. $\mathcal{B}_i^\tau \otimes \mathcal{B}_j^\tau \cong \mathcal{B}_j^\tau \otimes \mathcal{B}_i^\tau$ if $|i - j| > 1$.

Proof. All three statements follow directly from the compatibility of twisting with tensor products and direct sums. We check statement (2) as an example.

$$\begin{aligned}
(\mathcal{B}_i^\tau \otimes \mathcal{B}_{i+1}^\tau \otimes \mathcal{B}_i^\tau) \oplus \mathcal{B}_{i+1}^{\tau^3} &\cong (\mathcal{B}_i \otimes \mathcal{B}_{i+1} \otimes \mathcal{B}_i)^{\tau^3} \oplus \mathcal{B}_{i+1}^{\tau^3} \\
&\cong ((\mathcal{B}_i \otimes \mathcal{B}_{i+1} \otimes \mathcal{B}_i) \oplus \mathcal{B}_{i+1})^{\tau^3} \\
\text{by Prop. 3.2.1} \quad &\cong ((\mathcal{B}_{i+1} \otimes \mathcal{B}_i \otimes \mathcal{B}_{i+1}) \oplus \mathcal{B}_i)^{\tau^3} \\
&\cong (\mathcal{B}_{i+1}^\tau \otimes \mathcal{B}_i^\tau \otimes \mathcal{B}_{i+1}^\tau) \oplus \mathcal{B}_i^{\tau^3} \quad \square
\end{aligned}$$

We interpret these decomposition properties to mean that twisted Soergel bimodules categorify layered Murakami-Ohtsuki-Yamada relations as shown in Figure 3.6. We have also added a new relation that interchanges a layer containing only bivalent vertices with any other layer. The corresponding property of twisted Soergel bimodules is simply that $\mathcal{B}_i^\tau \otimes \mathcal{S}^\tau \cong \mathcal{S}^\tau \otimes \mathcal{B}_i^\tau$ for any i . As before, there is a common summand of $\mathcal{B}_i^\tau \otimes \mathcal{B}_{i+1}^\tau \otimes \mathcal{B}_i^\tau$ and $\mathcal{B}_{i+1}^\tau \otimes \mathcal{B}_i^\tau \otimes \mathcal{B}_{i+1}^\tau$, which is $\mathcal{B}_{i,i+1}^{\tau^3}$. The once-twisted version of this summand, $\mathcal{B}_{i,i+1}^\tau$ should be assigned to a new type of layer containing a six-valent vertex as in Figure 3.5. This summand was identified explicitly in the knot Floer algebras in Lemma 2.6.2 of Chapter 2 and seen to be $(\mathcal{S} \otimes_{\mathcal{S}_{i,i+1}} \mathcal{S})^\tau$.

3.3.3 The category \mathbf{SB}^τ

Define the category \mathbf{SB}^τ of twisted Soergel bimodules to be the smallest full subcategory of $\mathcal{S}\text{-grbimod}$ generated from the set $\{\mathcal{S}, \mathcal{S}^\tau, {}^\tau\mathcal{S}, B_1, \dots, B_{b-1}\}$ by (finite) tensor products over \mathcal{S} , (finite) direct sums, and grading shifts. This category includes $B_i^{\tau^k}$ for all $1 \leq i \leq b-1$ and $k \in \mathbb{Z}$, since $B_i \otimes \mathcal{S}^{\tau^k} \cong B_i^{\tau^k}$ and $\mathcal{S}^{\tau^{-k}} \cong {}^\tau{}^k\mathcal{S}$. It is a $\mathbb{Q}[t^{-1}, t]$ -linear, additive, monoidal category.

We would like to understand the split Grothendieck group of this new category \mathbf{SB}^τ , especially in comparison with the split Grothendieck group of the original category of Soergel bimodules. The split Grothendieck group of an additive category \mathcal{C} is generated by symbols $[M]$ for each object in \mathcal{C} , subject to the relation $[M] = [M'] + [M'']$ if $M \cong M' \oplus M''$ (see [17]). Understanding the split Grothendieck group then amounts to understanding direct sum decompositions in the category \mathcal{C} and classifying indecomposable objects. This is much more tractable in a category with the Krull-Schmidt

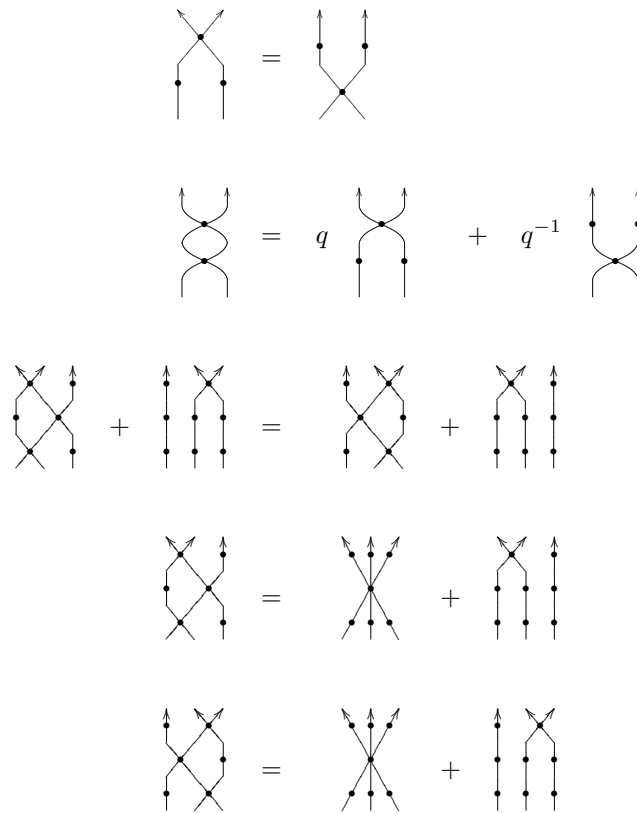

Figure 3.6: Layered versions of the MOY relations.

property, which says that every object is isomorphic to a finite direct sum of indecomposable objects, and that this decomposition is unique up to isomorphism. The category $\mathbb{Q}[t^{-1}, t][\underline{x}]$ -**grbimod** is Krull-Schmidt [19], so every object of \mathbf{SB}^τ does have a unique direct sum decomposition. However, there is no guarantee that the objects appearing in this decomposition are themselves twisted Soergel bimodules. Taking the Karoubi envelope of \mathbf{SB}^τ inserts all of the necessary direct summands, thereby allowing \mathbf{SB}^τ to inherit the Krull-Schmidt property from $\mathbb{Q}[t^{-1}, t][\underline{x}]$ -**grbimod**. The problem then is to identify the indecomposable objects in $\text{Kar}(\mathbf{SB}^\tau)$.

Soergel proves Theorem 3.2.1, about the decategorification of \mathbf{SB} by setting up a correspondence between the indecomposable objects in $\text{Kar}(\mathbf{SB})$ and the elements of the Kazhdan-Lusztig basis of the Hecke algebra. In fact, his argument holds over any infinite field with characteristic not equal to 2 (see [52, 53, 8] for more details), so there is a ring isomorphism

$$\Phi : H(b, q) \longrightarrow K_0 \left(\text{Kar} \left(\mathbf{SB}^{\mathbb{Q}[t^{-1}, t]} \right) \right).$$

The difficulty arises in understanding what happens when the twisted bimodules \mathcal{S}^τ and ${}^\tau\mathcal{S}$ are added to the generating set. As one might expect from the properties $M \otimes \mathcal{S}^\tau \cong M^\tau$ and ${}^\tau\mathcal{S} \otimes_{\mathcal{S}} \mathcal{S}^\tau \cong \mathcal{S}$, it turns out that adding these two objects to the generating set of $\mathbf{SB}^{\mathbb{Q}[t^{-1}, t]}$ corresponds to adjoining a new variable and its inverse to its Grothendieck group.

Proposition 3.3.5. *Let \mathbf{SB}^τ denote the category of twisted Soergel bimodules and $\text{Kar}(\mathbf{SB}^\tau)$ its Karoubi envelope. Let K_0 denote the split Grothendieck group and $H(b, q)$ the Hecke algebra with $b - 1$ generators over $\mathbb{Z}[q^{-1}, q]$. Then there is a ring isomorphism*

$$\Phi^\tau : H(b, q) \otimes_{\mathbb{Z}} \mathbb{Z}[\ell, \ell^{-1}] \longrightarrow K_0(\text{Kar}(\mathbf{SB}^\tau))$$

sending $1 \otimes 1$ to $[\mathcal{S}]$, $1 \otimes \ell$ to $[\mathcal{S}^\tau]$, $1 \otimes \ell^{-1}$ to $[{}^\tau\mathcal{S}]$, and $g_i \otimes 1$ to $[\mathcal{B}_i]$.

Proof of Proposition 3.3.5. The main idea here is that the indecomposable bimodules in $\text{Kar}(\mathbf{SB}^\tau)$ correspond to the τ^k twistings of the indecomposable bimodules in $\text{Kar}(\mathbf{SB}^{\mathbb{Q}[t^{-1}, t]})$, which Soergel's theorem identifies with the elements of the Kazhdan-Lusztig basis for the Hecke algebra. We show that \mathbf{SB}^τ is a direct sum of categories $\bigoplus_{k \in \mathbb{Z}} \mathbf{SB}_k^\tau$ in which each summand is equivalent as an additive category to $\mathbf{SB}^{\mathbb{Q}[t^{-1}, t]}$.

Define \mathbf{SB}_0^τ to be the smallest full subcategory of \mathbf{SB}^τ containing the objects $\mathcal{S}, B_1, \dots, B_{b-1}$ and closed under (finite) tensor products, (finite) direct sums, and grading shifts. There is a fully faithful inclusion of $\mathbf{SB}^{\mathbb{Q}[t^{-1}, t]}$ into \mathbf{SB}^τ as \mathbf{SB}_0^τ . Let \mathbf{SB}_k^τ be the subcategory of \mathbf{SB}^τ whose objects are B^{τ^k} for any object B in \mathbf{SB}_0^τ . Then \mathbf{SB}_k^τ is closed under direct sums and grading shifts, but not tensor products. There is an equivalence of additive categories between \mathbf{SB}_0^τ and \mathbf{SB}_k^τ given by $- \otimes \mathcal{S}^{\tau^k}$, which the first statement in Proposition 3.3.3 shows is fully faithful. Moreover, by the

second statement in Proposition 3.3.3, there are no non-trivial morphisms between \mathbf{SB}_k^τ and $\mathbf{SB}_{k'}^\tau$ for $k \neq k'$. Therefore, \mathbf{SB}^τ decomposes as a direct sum of categories

$$\mathbf{SB}^\tau \cong \bigoplus_{k \in \mathbb{Z}} \mathbf{SB}_k^\tau.$$

We have also established that \mathcal{S}^τ acts on this direct sum by taking \mathbf{SB}_k^τ to \mathbf{SB}_{k+1}^τ .

An object in the direct sum of categories has the form $M_{k_1} \oplus \cdots \oplus M_{k_p}$ for some $\{k_1, \dots, k_p\} \subset \mathbb{Z}$ and M_{k_i} an object in $\mathbf{SB}_{k_i}^\tau$. The indecomposables in the direct sum, then, must have only a single component M_k , which is indecomposable in \mathbf{SB}_k^τ . Also, the direct sum is compatible with taking the Karoubi envelope, so we have $\text{Kar}(\mathbf{SB}^\tau) \cong \bigoplus_{k \in \mathbb{Z}} \text{Kar}(\mathbf{SB}_k^\tau)$. Each summand $\text{Kar}(\mathbf{SB}_k^\tau)$ is equivalent to $\text{Kar}(\mathbf{SB}^{\mathbb{Q}[t^{-1}, t]})$ via the inclusion of $\text{Kar}(\mathbf{SB}_0^\tau)$ as $\text{Kar}(\mathbf{SB}_0^\tau)$, followed by $-\otimes \mathcal{S}^{\tau^k}$. Therefore, each summand is Krull-Schmidt with indecomposables in correspondence with the Kazhdan-Lusztig basis elements of the Hecke algebra. Composing Φ from Soergel's theorem with the map induced by the equivalence of categories, we have $\mathbb{Z}[q^{-1}, q]$ -module isomorphisms

$$\Phi_k^\tau : H(b, q) \rightarrow K_0(\text{Kar}(\mathbf{SB}_k^\tau))$$

taking 1 to \mathcal{S}^{τ^k} and g_i to $B_i^{\tau^k}$.

Combine the Φ_k^τ to define a $\mathbb{Z}[q^{-1}, q]$ -module isomorphism

$$\Phi^\tau : H(b, q) \otimes_{\mathbb{Z}} \mathbb{Z}[\ell, \ell^{-1}] \longrightarrow K_0(\text{Kar}(\mathbf{SB}^\tau))$$

by $\Phi^\tau(g \otimes \ell^k) = \Phi_k^\tau(g)$. Proposition 3.3.4 along with the previously identified action of $-\otimes \mathcal{S}^\tau$ as an endofunctor establishes that Φ^τ is in fact a ring isomorphism. \square

3.4 Twisted Rouquier complexes and a braid group action

We have at this point a map from layered singular braids to twisted Soergel bimodules that respects the Murakami-Ohtsuki-Yamada relations among layered singular braids, along with the extra relation of interchanging any row with a row containing only bivalent vertices. The extension to a braid group action proceeds exactly as it did for the usual Soergel bimodules: to the generators of the braid group, we assign complexes that categorify the singular skein relations

$$P(\text{crossing}) = P(\text{uncrossing}) + qP(\text{braid}), \quad \text{and} \quad P(\text{uncrossing}) = P(\text{braid}) + qP(\text{crossing}), \tag{3.5}$$

now with dots added to make the braid diagrams layered.

The layered braid diagrams defined in Chapter 2 correspond to an enlarged braid group $\text{Br}_b \oplus \mathbb{Z}\langle \lambda \rangle$ in which layers with only bivalent vertices are signified by the new generator λ . The usual generators

σ_i and σ_i^{-1} signify layers with the usual positive or negative crossing between strands i and $i + 1$, but now with bivalent vertices on all strands away from the crossing. We assign the following *twisted Rouquier complexes* to the generators of $\text{Br}_b \oplus \mathbb{Z}\langle \lambda \rangle$.

$$\begin{aligned} F^\tau(\sigma_i) : 0 &\rightarrow B_i^\tau[-2] \xrightarrow{1} \mathcal{S}^\tau[-2] \rightarrow 0 \\ F^\tau(\sigma_i^{-1}) : 0 &\rightarrow \mathcal{S}^\tau[2] \xrightarrow{tx_i \otimes 1 - 1 \otimes x_{i+1}} B_i^\tau \rightarrow 0 \\ F^\tau(\lambda) : 0 &\rightarrow \mathcal{S}^\tau \rightarrow 0 \\ F^\tau(\lambda^{-1}) : 0 &\rightarrow {}^\tau\mathcal{S} \rightarrow 0, \end{aligned}$$

where $[k]$ denotes a shift by k in the internal grading inherited from the grading on the strand algebra. Define a cohomological grading by placing B_i^τ in grading 0 in the first two complexes and placing \mathcal{S}^τ and ${}^\tau\mathcal{S}$ in grading 0 in the latter two complexes. As before, 1 denotes the map $1 \otimes 1 \mapsto 1$, extended to be an \mathcal{S} -bimodule map. In the second complex, $tx_i \otimes 1 - 1 \otimes x_{i+1}$ is the image of 1 . The rest of the map is defined by extending to an \mathcal{S} -bimodule map. For example, for $j \neq i, i + 1$, the image of x_j under the map in $F^\tau(\sigma_i^{-1})$ is determined by the requirements that

$$\begin{aligned} x_j \cdot 1 &\mapsto x_j \cdot (tx_i \otimes 1 - 1 \otimes x_{i+1}) = tx_i x_j \otimes 1 - x_j \otimes x_{i+1} \text{ and} \\ 1 \cdot t^{-1}x_j &\mapsto (tx_i \otimes 1 - 1 \otimes x_{i+1}) \cdot t^{-1}x_j = tx_i \otimes x_j - 1 \otimes x_{i+1}x_j, \end{aligned}$$

which are compatible because the two expressions on the right are equal.

Observe that although the maps in these twisted Rouquier complexes assigned to σ^{-1} appear less symmetric than those in the original Rouquier complexes, they are in fact not so different. In B_i^τ or B_i , we have the equation

$$\begin{aligned} (x_i + x_{i+1}) \otimes 1 &= 1 \otimes (x_i + x_{i+1}) \text{ or} \\ x_i \otimes 1 - 1 \otimes x_{i+1} &= -(x_{i+1} \otimes 1 - 1 \otimes x_i), \end{aligned}$$

which means that the original Rouquier complex maps could be written as $2(x_i \otimes 1 - 1 \otimes x_{i+1})$ instead. Twisted Rouquier complex maps differ from these by the expected factor of t on one side and the extra factor of 2. Had we chosen to use the more obvious generalization $(tx_i - tx_{i+1}) \otimes 1 + 1 \otimes (x_i - x_{i+1})$ of the original Rouquier complex map, we would have produced a homotopy equivalent complex, given that we are working over \mathbb{Q} .

Under the edge-strand correspondence, the maps in these twisted Rouquier complexes are the same as those in the knot Floer cube of resolutions. Ignoring gradings, we have the following commutative diagram involving the twisted Rouquier complex and the knot Floer complex for a

single negative crossing.

$$\begin{array}{ccc}
 S^\tau & \xrightarrow{tx_i \otimes 1 - 1 \otimes x_{i+1}} & B_i^\tau \\
 \downarrow \psi & & \downarrow \psi \\
 \mathbb{Q}[t^{-1}, t][y_1, \dots, y_b, z_1, \dots, z_b] & \xrightarrow{ty_i - z_{i+1}} & \mathbb{Q}[t^{-1}, t][y_1, \dots, y_b, z_1, \dots, z_b] \\
 \{ty_j - z_j\}_{j=1}^b & & \begin{array}{l} \{ty_j - z_j\}_{j \neq i, i+1} \\ t(y_i + y_{i+1}) - (z_i + z_{i+1}) \\ t^2 y_i y_{i+1} - z_i z_{i+1} \end{array}
 \end{array}$$

We may define the complex associated to a word $\sigma \in \text{Br}_b \oplus \mathbb{Z}\langle \lambda \rangle$ either by tensoring the twisted Rouquier complexes corresponding to each generator in the word or we may form a diagrammatic cube of resolutions, assign the appropriate twisted Soergel bimodule to each resolution, and then insert maps from the twisted Rouquier complexes on the appropriate edges. The result is the same either way, and we call it $F^\tau(\sigma)$. There is another sense in which $F^\tau(\sigma)$ is a twisted Rouquier complex. If $\sigma \in \text{Br}_b \oplus \langle \lambda \rangle$ is a braid with m layers (i.e. λ appears m times in σ) and $\bar{\sigma}$ is σ with all instances of λ removed, then the bimodules in each bigrading of $F^\tau(\sigma)$ are τ^m twistings of the bimodules in the corresponding bigradings of $F(\bar{\sigma})$. However, the maps in $F^\tau(\sigma)$ are also twisted, so it is not true that $F^\tau(\sigma)$ is simply $F(\bar{\sigma}) \otimes \mathcal{S}^{\tau^m}$.

We have now produced a map from layered braids to complexes of twisted Soergel bimodules. Tensoring with a twisted Rouquier complex is an endofunctor of $\text{Com}(\mathbf{SB}^\tau)$. We now prove that two words representing the same element of $\text{Br}_b \oplus \langle \lambda \rangle$ give isomorphic endofunctors. In particular, this means that the endofunctors $F^\tau(\sigma)$ are all invertible.

Lemma 3.4.1. *The complexes $F^\tau(\sigma_i)$, $F^\tau(\sigma_i^{-1})$, $F^\tau(\lambda)$, and $F^\tau(\lambda^{-1})$ act by invertible endofunctors on $\text{Com}(\mathbf{SB}^\tau)$ and the following complexes are isomorphic in the homotopy category of complexes $\text{Com}(\mathbf{SB}^\tau)$.*

1. $F^\tau(\lambda) \otimes_{\mathcal{S}} F^\tau(\lambda^{-1}) \cong (0 \rightarrow \mathcal{S} \rightarrow 0)$
2. $F^\tau(\sigma) \otimes_{\mathcal{S}} F^\tau(\lambda^{\pm 1}) \cong F^\tau(\lambda^{\pm 1}) \otimes_{\mathcal{S}} F^\tau(\sigma)$ for any braid word σ
3. $F^\tau(\sigma_i) \otimes_{\mathcal{S}} F^\tau(\sigma_j) \cong F^\tau(\sigma_j) \otimes_{\mathcal{S}} F^\tau(\sigma_i)$ if $|i - j| \geq 2$
4. $F^\tau(\sigma_i) \otimes_{\mathcal{S}} F^\tau(\sigma_i^{-1}) \cong F^\tau(\sigma_i^{-1}) \otimes_{\mathcal{S}} F^\tau(\sigma_i) \cong (0 \rightarrow \mathcal{S} \rightarrow 0)$
5. $F^\tau(\sigma_i) \otimes_{\mathcal{S}} F^\tau(\sigma_{i+1}) \otimes_{\mathcal{S}} F^\tau(\sigma_i) \cong F^\tau(\sigma_{i+1}) \otimes_{\mathcal{S}} F^\tau(\sigma_i) \otimes_{\mathcal{S}} F^\tau(\sigma_{i+1})$

Proof. The first two statements follow from facts we have already established about the twisted strand algebra: $\mathcal{S}^\tau \otimes_{\mathcal{S}} \mathcal{S} \cong \mathcal{S}$ and $\mathcal{S}^\tau \otimes_{\mathcal{S}} B_i^\tau \cong B_i \otimes_{\mathcal{S}} \mathcal{S}^\tau$ and similarly for ${}^\tau \mathcal{S}$, so $F^\tau(\lambda) \otimes_{\mathcal{S}} F^\tau(\lambda^{-1})$ is the identity endofunctor. The third statement holds because \mathcal{S}^τ commutes with any B_i^τ and because B_i^τ commutes with B_j^τ when strands i and j are not adjacent.

The remaining two statements are twisted analogues of the claim that Rouquier’s original complexes define a weak braid group action. We know from Proposition 3.3.4 that twisted Soergel bimodules decompose in the same way that usual Soergel bimodules do. These decompositions will imply the braid-like Reidemeister moves as long as they are compatible with the differentials appearing in $F^\tau(\sigma)$ and $F^\tau(\sigma^{-1})$. For example, we need not only that $B_i^\tau \otimes_{\mathcal{S}} B_i^\tau \cong B_i^\tau[1] \oplus B_i^\tau[-1]$, but that the differentials from $F^\tau(\sigma_i^{-1})$ and $F^\tau(\sigma_i)$ are inclusion and projection maps for the appropriate summands of $B_i^\tau[1] \oplus B_i^\tau[-1]$. For this, we appeal to the edge-strand correspondence and the proofs that the knot Floer algebras are invariant under Reidemeister moves II and III in Chapter 2. In those arguments, the necessary compatibility between twisted Rouquier complex differentials and Soergel bimodule decompositions were checked first for the quotient of the edge ring by local relations only, and then for the quotient by local and non-local relations. Simply ignore the latter part of the argument to get the result claimed here. Moreover, the calculations in Chapter 2 are done locally, in the minimal possible number of layers, so the edge labeling convention there is also consistent with non-closed braids. \square

Proof of Prop. 3.3.2. The proposition follows from Lemma 3.4.1 and an argument parallel to that in [50, Section 3.3]. Upon passing to the derived category, the twisted complexes $F^\tau(\sigma_i)$ and $F^\tau(\sigma_i^{-1})$ are both quasi-isomorphic to the complex

$$0 \rightarrow \mathcal{S}^{\tau \circ (i i + 1)} \rightarrow 0,$$

where $(i i + 1)$ is the automorphism of \mathcal{S} that transposes x_i and x_{i+1} . Therefore, the action of $\text{Br} \oplus \mathbb{Z}\langle \lambda \rangle$ collapses to a genuine action of $S_n \oplus \mathbb{Z}\langle \lambda \rangle$. The same argument given by Rouquier applies to show that the braid group action by twisted Rouquier complexes is genuine. \square

Grading conventions are again different between the twisted Soergel bimodules set-up (in which we have mimicked the conventions for HOMFLY-PT homology) and the knot Floer cube of resolutions. In each case there is an adjustment to the internal grading (quantum or singular Alexander, respectively) built into the complex associated to a crossing in order to make the maps homogenous. We call the resulting grading $\text{gr}_{\mathcal{S}Bq}$ in the (twisted) Soergel bimodules case. In the knot Floer case, it is the usual Alexander grading. The cohomological degrees in the two constructions differ by a shift. Table 3.1 summarizes the relationships among all of the gradings we have introduced.

We have produced in this section replicas of two of the three algebraic structures used to define HOMFLY-PT homology: an assignment of bimodules to layered singular braids from a category whose Grothendieck group is related to the Hecke algebra and an action of the (layered) braid group

Grading	Soergel Bimodules	Knot Floer Homology	Conversion
strand/edge	$\deg_{\text{SB}}(x_i)=2$	$\deg_{\text{HFK}}(x_i)=-1$	$\deg_{\text{SB}}=-2 \deg_{\text{HFK}}$
sing. quantum/ Alexander	\deg_{SB}	$A_I=\deg_{\text{HFK}}+s$	$\deg_{\text{SB}}=-2(A_I-s)$
cohomological	$\text{cohom}_{\text{SB}}=\text{wr}-\text{wr}_\sigma$	$\text{cohom}_{\text{HFK}}=c_+-\text{wr}_\sigma$	$\text{cohom}_{\text{SB}}=\text{cohom}_{\text{HFK}}-c_-$
quantum/ Alexander	$\text{gr}_{\text{SB}q}=\deg_{\text{SB}}-2\text{wr}-2\sigma_-$	$A=A_I-c_-+\text{cohom}_{\text{HFK}}$	$\text{gr}_{\text{SB}q}=-2A+2s$

Table 3.1: Dictionary of grading conventions for (twisted) Soergel bimodules and HFK. Let c_+ and c_- denote the number of positive resp. negative crossings in a braid diagram, σ denote the number of singular crossings in a singular braid diagram, and σ_+ and σ_- the number of singular crossings arising from positive resp. negative crossings. The symmetrizer s is $\frac{1}{2}(\sigma + b - 1)$, where b the number of braid strands in a diagram. The writhe and singular writhe are $\text{wr} = c_+ - c_-$ and $\text{wr}_\sigma = \sigma_+ - \sigma_-$.

on complexes of those bimodules. We expect that both of these assignments would extend to functors

$$\begin{aligned} \widehat{\mathcal{F}}_{\text{HFK}}^b &: \mathbf{SBrCob}_b \rightarrow S\text{-grbimod} \text{ and} \\ \mathcal{F}_{\text{HFK}}^b &: \mathbf{BrCob}_b \rightarrow \text{Com}(S\text{-grbimod}), \end{aligned}$$

but leave this question for another time. Instead, we move on to Chapter 4 for a consideration of braid closures and the appropriate replacement operation for Hochschild homology in the context of knot Floer homology.

Chapter 4

Braid Closures and Ideal Quotients

The goal of this chapter is to recover knot Floer homology from the braid invariant introduced in Chapter 3. We define an operation Qu that we claim converts the twisted Soergel bimodule associated to a layered singular braid in Chapter 3 to the algebra associated to its braid closure in Chapter 2. Applying this operation to each homological grading of $F^r(\sigma)$, the chain complex associated to a layered braid σ , produces a bigraded chain complex that is an invariant of the layered braid's closure. Under the edge-strand correspondence, this chain complex is conjectured to be the knot Floer cube of resolutions chain complex from Chapter 2 (with \mathbb{Q} replacing \mathbb{Z} as the ground ring). We prove a somewhat weaker statement, but expect that the full conjecture can be proved by similar methods.

Section 4.1 describes the operation Qu precisely, states the conjecture that Qu recovers the knot Floer cube of resolutions, and states the partial result in this direction that we prove here. The proof employs a computational device from commutative algebra called Gröbner bases. Section 4.2 briefly outlines the small slice of this theory that will be useful for our purposes. A more thorough treatment is provided in [1] or [7]. Section 4.3 sets up the application of Gröbner bases to our problem. The remaining sections of this chapter carry out the algorithm in full, less-than-enlightening detail.

4.1 The operation Qu

On twisted Soergel bimodules, the operation Qu is defined in two steps. Let $\sigma \in \text{Br}_b \oplus \mathbb{Z}\langle\lambda\rangle$ be a layered braid with m layers and D_σ a layered braid diagram for σ . Let $B_I^r(D_\sigma)$ be the twisted Soergel bimodule associated to the I -resolution of D_σ . Then $B_I^r(D_\sigma)$ is a bimodule over the strand algebra $\mathcal{S} = \mathbb{Q}[t^{-1}, t][x_1, \dots, x_b]$ (equivalently, a left $\mathcal{S} \otimes \mathcal{S}$ -module). Label the strands of D_σ so that 1 is closest to the braid axis and b is furthest from it. Step one of the operation Qu is to take

the quotient of $B_I^r(D_\sigma)$ by the sub-bimodule Z generated by

$$x_j \cdot (1 \otimes \cdots \otimes 1) - (1 \otimes \cdots \otimes 1) \cdot x_j = x_j \otimes 1 \otimes \cdots \otimes 1 - 1 \otimes \cdots \otimes 1 \otimes t^m x_j$$

for $1 \leq j \leq b-1$. We may regard $B_I^r(D_\sigma)/Z$ as an \mathcal{S} -module under the map $\mathcal{S} \otimes \mathcal{S} \rightarrow \mathcal{S}$ defined by $x_j \otimes 1 \mapsto x_j$ and $1 \otimes x_j \mapsto t^{-m} x_j$. In terms of the diagram D_σ , this quotient corresponds to attaching the top and bottom endpoints of strands 1 through $b-1$. Algebraically, we have equated the left and right actions of x_j on the \mathcal{S} -bimodule $B_I^r(D_\sigma)$ for $1 \leq j \leq b-1$. Defining a sub-algebra $\mathcal{S}' \subset \mathcal{S}$ by $\mathcal{S}' = \mathbb{Q}[t^{-1}, t][x_1, \dots, x_{b-1}]$, we could describe this first step of Qu as taking the co-invariants of \mathcal{S}' with respect to the bimodule $B_I^r(D_\sigma)$, which is (by definition) the zeroth Hochschild homology

$$B_I^r(D_\sigma)/Z = \text{HH}_0(\mathcal{S}', B_I^r(D_\sigma)).$$

We have not attached the top and bottom endpoints of the left-most strand in the braid diagram (strand b) because it is the strand that should carry the basepoint $*$ in a layered braid diagram for the braid closure $\widehat{\sigma}$ of σ . Therefore, the top and bottom edges on strand b should remain distinct in $B_I^r(D_\sigma)/Z$. We will think of $B_I^r(D_\sigma)/Z$ as being associated to a layered diagram of $\widehat{\sigma}$ with a basepoint $*$ on the left-most strand as in Chapter 2.

The second step is to quotient by the kernel of multiplication by the product of the strand variables $x_1 \cdots x_{b-1}$ on $B_I^r(D_\sigma)/Z$. This step is meant to recover the non-local relations used to define $\mathcal{A}_I(D_{\widehat{\sigma}})$. Putting these steps together, we define

$$\text{Qu}(B_I^r(D_\sigma)) = \frac{\text{HH}_0(\mathcal{S}', B_I^r(D_\sigma))}{\ker(x_1 \cdots x_{b-1})}$$

and conjecture that it recovers the knot Floer algebra associated to a closed singular braid.

Conjecture (Conjecture 4.1.1). *Let σ be a braid, D_σ a layered braid diagram, and $D_{\widehat{\sigma}}$ a layered braid diagram for its closure. Let $B_I^r(D_\sigma)$ be the twisted Soergel bimodule associated to the I -resolution of D_σ in Chapter 3. Let $\mathcal{A}_I(D_{\widehat{\sigma}})$ be the algebra associated to the I -resolution of $D_{\widehat{\sigma}}$ in the knot Floer cube of resolutions of Chapter 2, defined over $\widehat{\mathcal{R}} = \mathbb{Z}[t^{-1}, t]$. Then*

$$\text{Qu}(B_I^r(D_\sigma)) \cong \mathcal{A}_I(D_{\widehat{\sigma}}) \otimes_{\mathbb{Z}} \mathbb{Q}. \quad (4.1)$$

The operation Qu plays the role that Hochschild homology does in HOMFLY-PT homology: it takes \mathcal{S}' -bimodules to left \mathcal{S}' -modules¹ and replaces algebraic objects naturally associated to braids with algebraic objects naturally associated to closed braids. However, the new operation certainly

¹ HOMFLY-PT homology is defined without using a basepoint on the outermost edge of a diagram, so in fact the Hochschild homology there is applied to \mathcal{S} rather than the sub-algebra \mathcal{S}' , which means that \mathcal{S} -bimodules become left \mathcal{S} -modules.

uses nowhere near the full strength of Hochschild homology, which is the derived functor of the co-invariants functor we apply as the first step of Qu. It would be interesting to understand the properties of this operation more precisely, especially to see whether it can be reproduced via an extra set of differentials on the Hochschild chain complex of $F^\tau(\sigma)$, as conjectured in [6]. We plan to return to these questions in future work.

This rather mysterious operation is somewhat clearer on the other side of the edge-strand correspondence. As we showed in Proposition 3.3.1, the twisted Soergel bimodule associated to a layered singular braid can instead be viewed as $\mathcal{A}_I(D_\sigma) \otimes_{\mathbb{Z}} \mathbb{Q}$, where

$$\mathcal{A}_I(D_\sigma) = \frac{\mathbb{Z}[t^{-1}, t][\underline{x}(D_\sigma)]}{\mathcal{L}_I(D_\sigma) + \mathcal{N}_I(D_\sigma)}$$

as defined in Section 3.1. We proved in Proposition 3.1.1 that $\mathcal{N}_I(D_\sigma) \subset \mathcal{L}_I(D_\sigma)$ when D_σ is a layered braid diagram, so in fact we could have defined $\mathcal{A}_I(D_\sigma) = \frac{\mathbb{Z}[t^{-1}, t][\underline{x}(D_\sigma)]}{\mathcal{L}_I(D_\sigma)}$ instead.

Since the edges incident to the top and bottom boundaries of the braid will play a special role in the closure operation Qu, we introduce a notational shorthand for them and change our other notation to emphasize that edges between vertices of the graph obtained by resolving a braid play a different role from edges between vertices in the resolution and the boundaries of the braid. Let $z_\tau^1, \dots, z_\tau^b$ be the edges incident to the top boundary of D_σ , labeled such that z_τ^i is on the i^{th} strand. Let $z_\beta^1, \dots, z_\beta^b$ be the edges incident to the bottom boundary of D_σ labeled such that z_β^i is on the i^{th} strand. We treat these not as new variables, but simply alternate names for the appropriate edges already labeled by some subset of the variables $\underline{x}(D_\sigma)$ in the edge ring. We call edges labeled with a z_τ^i or z_β^i *boundary edges* and edges between vertices in D_σ *internal edges*. Our new convention will be that $x_{\Gamma, D \setminus \Gamma}$ does *not* include edges from Γ to the top boundary of the braid and likewise $x_{D \setminus \Gamma, \Gamma}$ does *not* include edges from the bottom boundary of the braid to Γ . The appropriate notation for the non-local relation associated to a subset Γ in the I -resolution of D_σ is now

$$g_\Gamma = t^{\mathbf{w}(\Gamma)} x_{\Gamma, D \setminus \Gamma} z_{\Gamma, \tau} - x_{D \setminus \Gamma, \Gamma} z_{\beta, \Gamma}.$$

Under the edge-strand correspondence, the first step in the operation Qu is to take a quotient by the ideal

$$\mathcal{Z} = (z_\tau^1 - z_\beta^1, \dots, z_\tau^{b-1} - z_\beta^{b-1}) \subset \mathbb{Z}[t^{-1}, t][\underline{x}(D_\sigma)].$$

We call \mathcal{Z} the *closure ideal* and the set of generators above the *closure relations*. The second step of Qu is to take a quotient by the kernel of multiplication by $z_\tau^1 \cdots z_\tau^{b-1}$ as an automorphism of $\mathcal{A}_I(D_\sigma)/\mathcal{Z}$. By definition, this kernel consists of polynomials $p \in \mathbb{Z}[t^{-1}, t][\underline{x}(D_\sigma)]$ such that $z_\tau^1 \cdots z_\tau^{b-1} p \in \mathcal{L}_I(D_\sigma) + \mathcal{N}_I(D_\sigma) + \mathcal{Z}$. In other words, it is the ideal quotient of $\mathcal{L}_I(D_\sigma) + \mathcal{N}_I(D_\sigma) + \mathcal{Z}$ by the principal ideal $(z_\tau^1 \cdots z_\tau^{b-1})$.

Definition 4.1.1. Let I, J be ideals in a ring R . The ideal quotient of I by J is

$$I : J = \{r \in R \mid rJ \subset I\}.$$

Note that I is always contained in $I : J$.

Putting the two steps together, the operation Qu is defined to be

$$\frac{\mathbb{Z}[t^{-1}, t][\underline{x}(D_\sigma)]}{\mathcal{L}_I(D_\sigma) + \mathcal{N}_I(D_\sigma)} \xrightarrow{\text{Qu}} \frac{\mathbb{Z}[t^{-1}, t][\underline{x}(D_\sigma)]}{(\mathcal{L}_I(D_\sigma) + \mathcal{N}_I(D_\sigma) + \mathcal{Z}) : (z_\tau^1 \cdots z_\tau^{b-1})}$$

Our conjecture is that Qu recovers the algebra $\mathcal{A}_I(D_{\hat{\sigma}})$ associated to the closure of the I -resolution of the layered singular braid diagram $D_{\hat{\sigma}}$, which means that the ideal quotient should recover the non-local relations associated to subsets in the closed braid diagram. A precise formulation of the conjecture stated in Chapter 1 and earlier in this chapter is as follows.

Conjecture 4.1.1. Let σ be a braid, D_σ a layered braid diagram, and $D_{\hat{\sigma}}$ a layered braid diagram for its closure. Then

$$(\mathcal{L}_I(D_\sigma) + \mathcal{N}_I(D_\sigma) + \mathcal{Z}) : (z_\tau^1 \cdots z_\tau^{b-1}) = \mathcal{L}_I(D_{\hat{\sigma}}) + \mathcal{N}_I(D_{\hat{\sigma}}) + \mathcal{Z} \quad (4.2)$$

as ideals in $\mathbb{Z}[t^{-1}, t][\underline{x}(D_\sigma)]$.

Building on the intuition behind the proof that $\mathcal{N}_I(D_\sigma) \subset \mathcal{L}_I(D_\sigma)$, we introduce the ideal quotient because it allows us to build the non-local relations in $\mathcal{N}_I(D_{\hat{\sigma}})$ by taking edge-ring-linear combinations of quadratic relations, then dividing by as many of the z_τ^j as desired. The non-local relation associated to a subset in a closed braid diagram differs from the non-local relation associated to the same subset in the non-closed braid diagram only because edges incident to the top and bottom boundaries of the braid are considered distinct in the former diagram, but not in the latter. If the top-most and bottom-most edges on a strand are both incident to vertices in a certain subset, then they are edges “from the subset to its complement” or “from the complement to the subset” in the non-closed diagram, but not in the closed diagram. The result of Proposition 3.1.1 can be re-stated as $\mathcal{L}_I(D_{\hat{\sigma}}) + \mathcal{N}_I(D_{\hat{\sigma}}) + \mathcal{Z} \subset (\mathcal{L}_I(D_\sigma) + \mathcal{N}_I(D_\sigma) + \mathcal{Z}) : (z_\tau^1 \cdots z_\tau^{b-1})$. The difficulty is in showing that the opposite inclusion holds.

For now, we prove a weaker statement than that of Conjecture 4.1.1. First, we work over \mathbb{Q} rather than $\mathbb{Q}[t^{-1}, t]$ or $\mathbb{Z}[t^{-1}, t]$. Given a braid σ , layered braid diagram D_σ , and a layered braid diagram $D_{\hat{\sigma}}$ for the closure of σ , let $\mathcal{E}'(D_\sigma)$ and $\mathcal{E}'(D_{\hat{\sigma}})$ be polynomial rings over \mathbb{Q} with one indeterminate for each edge in D_σ or $D_{\hat{\sigma}}$ respectively. Define $\mathcal{L}'_I(D_\sigma)$ and $\mathcal{L}'_I(D_{\hat{\sigma}})$ to be the ideals of $\mathcal{E}'(D_\sigma)$ and $\mathcal{E}'(D_{\hat{\sigma}})$ obtained by removing the extra parameter t in the definition of the generating sets of $\mathcal{L}_I(D_\sigma)$ and $\mathcal{L}_I(D_{\hat{\sigma}})$. In other words, $\mathcal{L}_I(D_\sigma)$ and $\mathcal{L}_I(D_{\hat{\sigma}})$ are generated by local relations

$x_a + x_b - x_c - x_d$ and $x_a x_b - x_c x_d$ for each 4-valent vertex and $x_{i+1} - x_i$ for each bivalent vertex in D_σ or $D_{\hat{\sigma}}$ as appropriate. Similarly, define modified ideals of non-local relations $\mathcal{N}'_I(D_\sigma)$ and $\mathcal{N}'_I(D_{\hat{\sigma}})$ by removing the extra parameter t from the corresponding definitions in Chapters 2 and 3. Finally, let $\mathcal{Q}'_I(D_\sigma) \subset \mathcal{L}'_I(D_\sigma)$ and $\mathcal{Q}'_I(D_{\hat{\sigma}}) \subset \mathcal{L}'_I(D_{\hat{\sigma}})$ denote the ideals generated by only the quadratic generators $x_a x_b - x_c x_d$ associated to 4-valent vertices and the generators $x_{i+1} - x_i$ associated to bivalent vertices. The main result in this chapter is as follows.

Theorem 4.1.1. *With notation as above, the following holds among ideals of $\mathcal{E}'(D_\sigma)$.*

$$(\mathcal{Q}'_I(D_\sigma) + \mathcal{N}'_I(D_\sigma) + \mathcal{Z}) : (z_\tau^1 \cdots z_\tau^{b-1}) = \mathcal{Q}'_I(D_{\hat{\sigma}}) + \mathcal{N}'_I(D_{\hat{\sigma}}) + \mathcal{Z} \quad (4.3)$$

We expect that the proof of this result can be quickly adapted to work over $\mathbb{Q}[t^{-1}, t]$ with $\mathcal{Q}'_I(D_\sigma)$, $\mathcal{Q}'_I(D_{\hat{\sigma}})$, $\mathcal{N}'_I(D_\sigma)$, and $\mathcal{N}'_I(D_{\hat{\sigma}})$ replaced by the original ideals of relations that do use the parameter t . We expect the same method of proof to apply to the stronger statement of Conjecture 4.1.1, but re-introducing the linear local relations associated to 4-valent vertices may complicate the argument considerably.

4.2 Background: Gröbner bases and Buchberger's algorithm

We approach Theorem 4.1.1 as a calculation: given generating sets for two ideals in a polynomial ring, create a generating set for their ideal quotient. In fact, we would like to re-create a previously specified generating set. Gröbner bases are a convenient tool for this sort of commutative algebra calculation. They make it possible to generalize sensibly the division algorithm for single-variable polynomials to a division algorithm for multivariable polynomials, thereby reducing certain difficult questions in commutative algebra and algebraic geometry to computational problems. Gröbner bases are the foundation of computer algebra programs that do commutative algebra in polynomial rings, such as Macaulay 2 [11]. In this section, we define Gröbner bases, describe an algorithm for converting an arbitrary generating set for an ideal into a Gröbner basis, and explain how Gröbner bases can be used to calculate generating sets for ideal intersections and quotients. The exposition here is an adaptation of that in [1].

4.2.1 Monomial orderings

Let k be a field and $k[x_0, \dots, x_n] = k[\underline{x}]$ a polynomial ring over it.²

² Much of this material generalizes to the case where k is a Noetherian commutative ring, but certain computability properties are required of the ring for the full theory of Gröbner bases to generalize.

Definition 4.2.1. A monomial ordering is a total ordering of the monomials $x_0^{\alpha_0} \cdots x_n^{\alpha_n}$ in $k[\underline{x}]$ that satisfies

1. $1 < x_0^{\alpha_0} \cdots x_n^{\alpha_n}$ for all monomials with α_i not all zero, and
2. $y < y'$ implies $yz < y'z$ for any monomials y, y', z in $k[\underline{x}]$.

We will use the lexicographic ordering on $k[\underline{x}]$ in which $x_0 > x_1 > \cdots > x_n > 1$. This means that $x_0^{\alpha_0} \cdots x_n^{\alpha_n} > x_0^{\beta_0} \cdots x_n^{\beta_n}$ when $\alpha_i > \beta_i$ for the first i at which the exponents differ. The largest monomial is written first. For example, the following polynomials are written correctly with respect to the lexicographic term order.

$$f_1 = x_1^2 x_2 - x_1 x_2^2 \quad f_2 = 2x_1 - x_2 x_3 x_4 \quad f_3 = x_5 + 4x_6^3 - 1$$

Throughout the remainder of this chapter, we will write polynomials with respect to the lexicographic order unless we specify otherwise. Given a monomial ordering, we will denote the leading term and the leading monomial of a polynomial $f \in k[\underline{x}]$ by $\text{LT}(f)$ and $\text{LM}(f)$ respectively. For example, $\text{LT}(f_2) = 2x_1$ and $\text{LM}(f_2) = x_1$. There will be no difference between leading terms and leading monomials for most of this chapter because our coefficients are always ± 1 .

4.2.2 Gröbner bases and the division algorithm

A Gröbner basis is a generating set for an ideal that accounts for all possible leading monomials of polynomials in that ideal.

Definition 4.2.2. A Gröbner basis for an ideal $I \subset k[\underline{x}]$ is a set of polynomials g_1, \dots, g_k in I such that for any $f \in I$, there is some i for which $\text{LM}(g_i)$ divides $\text{LM}(f)$.

It follows from the Hilbert Basis Theorem and a few basic observations that every nonzero ideal in $k[\underline{x}]$ has a Gröbner basis [1, Corollary 1.6.5]. Gröbner bases are not unique and are typically highly redundant; an ideal typically has a smaller generating set that is not a Gröbner basis.

The key advantage of Gröbner bases over other generating sets is that they make it possible to generalize the division algorithm to multivariable polynomials in a useful way. Generalizing the algorithm is straightforward enough: To divide f by g in $k[\underline{x}]$, we see whether $\text{LM}(g)$ divides $\text{LM}(f)$. If it does, we record $\text{LM}(f)/\text{LM}(g)$ as a term of the quotient and replace f by $f - \frac{\text{LM}(f)}{\text{LM}(g)}g$. If not, we record $\text{LT}(f)$ as a term in the remainder and replace f with $f - \text{LT}(f)$. Continuing this process as long as possible, we eventually obtain a decomposition of f as $f = qg + r$ for some $q, r \in k[\underline{x}]$. We may also divide f by a collection of polynomials g_1, \dots, g_k to obtain a decomposition $f = q_1 g_1 + \cdots + q_k g_k + r$. (Such a calculation is not interesting in the single variable case, since

every ideal in $k[x]$ is principal.) At each step, we look for the first i such that $\text{LM}(g_i)$ divides $\text{LM}(f)$, then record $\text{LM}(f)/\text{LM}(g_i)$ as a term in the quotient q_i and replace f by $f - \frac{\text{LM}(f)}{\text{LM}(g_i)}g_i$. If no $\text{LM}(g_i)$ divides $\text{LM}(f)$, then we record $\text{LT}(f)$ as a term in the remainder r and replace f with $f - \text{LT}(f)$. We will write

$$f \xrightarrow{g_1, \dots, g_k} r$$

and say “ f reduces to r via g_1, \dots, g_k ” if r is obtained as a remainder when using this algorithm to divide f by g_1, \dots, g_k . In general, the result of this algorithm depends on the monomial ordering chosen on $k[\underline{x}]$ and the order in which the polynomials g_1, \dots, g_k are listed. Neither the quotients q_1, \dots, q_k nor the remainder r are unique. Consequently, this generalized division algorithm on its own is of little use. It is not true, for example, that the remainder r is zero if and only if f is in the ideal generated by g_1, \dots, g_k .

However, if g_1, \dots, g_k are a Gröbner basis for the ideal they generate, then the remainder r is unique: it does not depend on the monomial ordering or on the order in which the g_i are listed. The quotients are still not unique, but the uniqueness of the remainder is sufficient to make the generalized division algorithm useful for commutative algebra computations. If g_1, \dots, g_k are a Gröbner basis for the ideal they generate, then $f \in (g_1, \dots, g_k)$ if and only if f reduces to zero via g_1, \dots, g_k .

4.2.3 Buchberger’s algorithm and ideal quotients

Buchberger [4] developed an algorithm for converting any generating set of an ideal into a Gröbner basis. Such an algorithm must produce new generators that account for all possible leading monomials of polynomials in the ideal. New leading monomials arise when a linear combination of existing generators causes their leading terms to cancel. Buchberger’s algorithm systematically produces these cancellations using S-polynomials.

Definition 4.2.3. *The S-polynomial of two non-zero polynomials $f, g \in k[\underline{x}]$ is*

$$S(f, g) = \frac{\text{lcm}(\text{LM}(f), \text{LM}(g))}{\text{LT}(f)}f - \frac{\text{lcm}(\text{LM}(f), \text{LM}(g))}{\text{LT}(g)}g,$$

where $f' = f - \text{LT}(f)$ and $g' = g - \text{LT}(g)$.

If $\text{LT}(f) = \text{LM}(f)$ and $\text{LT}(g) = \text{LM}(g)$, as will be the case throughout this chapter, then the formula for an S-polynomial simplifies to

$$S(f, g) = \frac{\text{LM}(f)\text{LM}(g)}{\text{gcd}(\text{LM}(f), \text{LM}(g))}f' - \frac{\text{LM}(f)\text{LM}(g)}{\text{gcd}(\text{LM}(f), \text{LM}(g))}g'.$$

Buchberger's theorem [1, Theorem 1.7.4] is that a generating set g_1, \dots, g_k for an ideal $I \subset k[\underline{x}]$ is a Gröbner basis for I if and only if $S(g_i, g_j) \xrightarrow{g_1, \dots, g_k} 0$ for all $i \neq j$. Buchberger's algorithm, then, is as follows.

1. Let g_1, \dots, g_k be a generating set for an ideal $I \subset k[\underline{x}]$.
2. Compute $S(g_i, g_j)$ for some $i \neq j$ and attempt to reduce it via g_1, \dots, g_k using the generalized division algorithm.
3. If $S(g_i, g_j) \xrightarrow{g_1, \dots, g_k} 0$, go back to the previous step and compute a different S-polynomial. If $S(g_i, g_j) \xrightarrow{g_1, \dots, g_k} r$ and $r \neq 0$, then add r to a working basis.
4. Repeat the previous two steps until a basis g_1, \dots, g_{k+s} is obtained for which $S(g_i, g_j) \xrightarrow{g_1, \dots, g_{k+s}} 0$ for all $i \neq j$.

Buchberger [4] proved that this algorithm terminates and produces a Gröbner basis for I .

We will use Buchberger's algorithm to produce an explicit generating set for $(\mathcal{Q}'_I(D_\sigma) + \mathcal{N}'_I(D_\sigma) + \mathcal{Z}) : (z_\tau^1 \cdots z_\tau^{b-1})$ in terms of the generating sets for $\mathcal{Q}'_I(D_\sigma)$, $\mathcal{N}'_I(D_\sigma)$ and \mathcal{Z} . The generating set we produce will be readily recognizable as the generators by which $\mathcal{Q}'_I(D_{\hat{\sigma}})$, \mathcal{Z} , and $\mathcal{N}'_I(D_{\hat{\sigma}})$ were defined, so this computation will prove Theorem 4.1.1. The first step is to produce a generating set for the intersection $(\mathcal{Q}'_I(D_\sigma) + \mathcal{N}'_I(D_\sigma) + \mathcal{Z}) \cap (z_\tau^1 \cdots z_\tau^{b-1})$. The following proposition explains how a generating set for an intersection yields a generating set for a quotient.

Proposition 4.2.1. *Let $I \subset R$ be an ideal in a commutative ring and $x \in R$ not a zero divisor. If h_1, \dots, h_k is a generating set for $I \cap (x)$, then $\frac{h_1}{x}, \dots, \frac{h_k}{x}$ is a generating set for $I : (x)$.*

Proof. For polynomial rings, this is [5, Theorem 11, Chapter 4]. We repeat the straightforward argument given there to clarify why the non-zero-divisor hypothesis is needed if R is not a polynomial ring. Since each $h_j \in I \cap (x)$, each $h_j \in (x)$, which means there exists $h'_j \in R$ such that $h'_j x = h_j$. Suppose $f = a_1 h'_1 + \cdots + a_k h'_k$ for some $a_1, \dots, a_k \in R$. Then $fx = a_1 h_1 + \cdots + a_k h_k$. So $fx \in I \cap (x)$. In particular $fx \in I$, so $f \in I : (x)$. Suppose $f \in I : (x)$. Then $fx \in I$ and $fx \in (x)$, so there exist $a_1, \dots, a_k \in R$ such that $fx = a_1 h_1 + \cdots + a_k h_k = a_1 h'_1 x + \cdots + a_k h'_k x = (a_1 h'_1 + \cdots + a_k h'_k)x$. Since x is not a zero divisor, we may cancel to obtain $f = a_1 h'_1 + \cdots + a_k h'_k$. \square

To produce a Gröbner basis for an intersection, we follow the method prescribed in [1, Section 2.3]. Suppose that $I, J \subset k[x_0, \dots, x_n]$ are ideals with generating sets p_1, \dots, p_k and q_1, \dots, q_m respectively. Enlarge the polynomial ring to include a dummy variable ν . Define the monomial order on $k[x_0, \dots, x_n, \nu]$ to be lexicographic with $\nu > x_0 > \cdots > x_n > 1$. (The lexicographic

ordering is a special case of an “elimination ordering” which is what is actually required for this procedure to work.) Then

$$I \cap J = (\nu I + (1 - \nu)J) \cap k[x_0, \dots, x_n]$$

and a Gröbner basis for $I \cap J$ can be obtained from a Gröbner basis for $\nu I + (1 - \nu)J$ by intersecting the basis with $k[x_0, \dots, x_n]$ [1, Theorem 2.3.4]. Therefore, to obtain a basis for $I \cap J$, we apply Buchberger’s algorithm to the basis

$$\nu p_1, \dots, \nu p_k, (1 - \nu)q_1, \dots, (1 - \nu)q_k$$

and discard any generator in which ν appears.

4.2.4 Simplifying Gröbner basis computations

We record here a collection of propositions that will simplify computations encountered when applying Buchberger’s algorithm. We assume throughout that all coefficients are ± 1 and use LT in place of LM in all S-polynomials. First, we establish that Buchberger’s algorithm applied to a basis that consists of differences of monomials will produce a basis that consists of differences of monomials.

Proposition 4.2.2. *If h_1, \dots, h_k are a basis for an ideal I and each h_i is a difference of monomials $h'_i - h''_i$, then the Gröbner basis obtained by applying Buchberger’s algorithm to h_1, \dots, h_k will also consist of differences of monomials.*

Proof. We first check that the S-polynomial of two differences of monomials is again a difference of monomials. Let $d = \gcd(\text{LT}(h'_i), \text{LT}(h''_i))$. Then

$$S(h'_i - h''_i, h'_j - h''_j) = \frac{h'_j}{d}(-h''_i) - \frac{h'_i}{d}(-h''_j),$$

which may not be the correct term order, but is in either case a difference of monomials.

The other steps of Buchberger’s algorithm are applications of the generalized division algorithm. If a difference of monomials is being reduced by other differences of monomials, then each step of the division algorithm involves subtracting one difference of monomials from another such that their leading terms cancel. The result is the difference of their trailing terms, which is again a difference of monomials. \square

Second, we notice that there are some situations in which there is no need to compute an S-polynomial explicitly. In other situations, we can compute many S-polynomials in terms of a single simpler S-polynomial.

Proposition 4.2.3. *Let $f, g \in k[\underline{x}]$. If $\gcd(\text{LT}(f), \text{LT}(g)) = 1$, then $S(f, g) \xrightarrow{f, g} 0$.*

Proof. Let $f = \text{LT}(f) + f'$ and $g = \text{LT}(g) + g'$. Then we can compute and reduce $S(f, g)$ as follows.

The two possible term orders are considered in two columns.

$$\begin{array}{ll}
 S(f, g) = \text{LT}(g)f' - \text{LT}(f)g' & \text{or } S(f, g) = -\text{LT}(f)g' + \text{LT}(g)f' \\
 \text{reduce } -f'(\text{LT}(g) + g') & \text{reduce } +g'(\text{LT}(f) + f') \\
 = -g'(\text{LT}(f) + f') & = f'(\text{LT}(g) + g') \\
 \text{reduce } +g'f & \text{reduce } +f'g \\
 = 0 & = 0
 \end{array}
 \quad \square$$

Proposition 4.2.4. *Let $f, g \in k[\underline{x}]$. For any $a \in k[\underline{x}]$,*

$$S(af, ag) = aS(f, g).$$

If $\gcd(a, b) = \gcd(a, \text{LT}(g)) = \gcd(b, \text{LT}(f)) = 1$, then

$$S(af, bg) = abS(f, g).$$

Proof. Let $d = \gcd(\text{LT}(f), \text{LT}(g))$ and $f = \text{LT}(f) + f'$ and $g = \text{LT}(g) + g'$. Then we compute as follows for the first claim.

$$\begin{aligned}
 S(af, ag) &= \frac{a\text{LT}(g)}{ad}af' - \frac{a\text{LT}(f)}{ad}ag' \\
 &= a \left(\frac{\text{LT}(g)}{d}f' - \frac{\text{LT}(f)}{d}g' \right) \\
 &= aS(f, g)
 \end{aligned}$$

For the second claim, the key observation is that $\text{lcm}(af, bg) = ab\text{lcm}(f, g)$ and the computation is as follows.

$$\begin{aligned}
 S(af, bg) &= \frac{ab\text{lcm}(f, g)}{a\text{LT}(f)}af' - \frac{ab\text{lcm}(f, g)}{b\text{LT}(g)}bg' \\
 &= ab \left(\frac{\text{lcm}(f, g)}{\text{LT}(f)}f' - \frac{\text{lcm}(f, g)}{\text{LT}(g)}g' \right) \\
 &= abS(f, g)
 \end{aligned}
 \quad \square$$

Finally, we will sometimes encounter expressions with unknown term order after computing an S-polynomial. The following proposition allows us to reduce some such expressions without ever determining their term order.

Proposition 4.2.5. *Let $p, q, r, s \in k[\underline{x}]$ be monomials whose relationships to each other under the monomial ordering are unknown. Then whichever of $ps - rq$ or $rq - ps$ is correctly ordered is reducible by the correctly ordered versions of $p - q$ and $r - s$.*

Proof. Suppose that $ps - rq$ is correctly ordered, so $ps > rq$. Then either $p > q$ or $s > r$ or both. Assume without loss of generality that $p > q$. Then term orders are correct in the following computation.

$$\begin{aligned} & ps - rq \\ \text{reduce: } & -s(p - q) \\ & = q(s - r) \text{ or } q(r - s) \end{aligned}$$

The term order in the last line depends on whether $r < s$ or $s < r$. Either way, the last expression reduces by the version of $r - s$ with the correct term order.

If instead $rq - ps$ is correctly ordered, then either $q > p$ or $r > s$ or both. Without loss of generality, assume $q > p$. Reduce by $q - p$ to get $p(r - s)$ or $p(s - r)$ depending on which term order is correct for $r - s$. Either way, the result reduces by the correctly ordered version of $r - s$. \square

4.3 Buchberger's algorithm: Preliminaries

Gröbner bases and Buchberger's algorithm offer a concrete, if computationally intensive, approach to our claim that the ideal of non-local relations arises as an ideal quotient of the quadratic and closure relations by the product of the edges incident to the top boundary of the braid. With a carefully chosen monomial order, the computations and reductions of S-polynomials prescribed by Buchberger's algorithm actually produce exactly the standard non-local relations associated to subsets in a layered (closed) braid diagram. Moreover, it is possible to interpret all S-polynomial computations with reference to the braid diagram, and thereby ensure that Buchberger's algorithm produces no extraneous generators for the ideal quotient aside from the expected quadratic, closure, and non-local relations.

The first step is to define a monomial ordering on the edge ring associated to a layered braid diagram. We do this by re-labeling edges. Let D_σ be a layered braid diagram for the layered braid $\sigma \in \text{Br}_b \oplus \langle \lambda \rangle$. Label the edges of D_σ with $x_0, \dots, x_{(m+1)b-1}$ from top to bottom, right to left. Using the linear relations $x_i - x_{i+1}$ associated to bivalent vertices, eliminate edge variables associated to the incoming edges of bivalent vertices. Let x_0, \dots, x_n be the remaining edge variables so that the edge ring $\mathcal{E}'(D_\sigma)$ is $\mathbb{Q}[\underline{x}']$. Let $z_\tau = \prod_{i=1}^{b-1} z_\tau^i$ denote the product of the edge variables incident to the top boundary of D_σ , labeled from right to left and excluding the outermost edge. Let $z_\beta = \prod_{i=1}^{b-1} z_\beta^i$ denote the similar product of the edge variables incident to the bottom boundary of D_σ . For simplicity, we will drop σ from the notation in most of this chapter, since the braid will remain fixed throughout, and use D to denote a complete resolution of D_σ .

The algorithm for finding a Gröbner basis of the intersection $(\mathcal{Q}'_I(D_\sigma) + \mathcal{N}'_I(D_\sigma) + \mathcal{Z}) \cap (z_\tau)$ takes place in the ring $\mathbb{Q}[\underline{x}', \nu]$ with the lexicographic ordering where $\nu > x_0 > \cdots > x_n$. This ordering and the edge labeling rules above guarantee that the edges incident to any 4-valent vertex have a consistent order: upper right, lower right, upper left, lower left. Let q_0, \dots, q_m denote the standard quadratic relations associated to 4-valent vertices presented as differences of monomials. With respect to this monomial ordering, q_i is written $q_i^{\text{out}} - q_i^{\text{in}}$, where q_i^{out} is the product of the outgoing edges from vertex i and q_i^{in} is the product of incoming edges to vertex i . The standard generators of the ideal of closure relations are written $z_\tau^i - z_\beta^i$.

As before, we will write $x_{\Gamma, \Delta}$ for the product of edges in D from $\Gamma \subset D$ to $\Delta \subset D$. Note that such products cannot be divisible by z_τ^j or z_β^j for any j . We will write $z_{\Gamma, \tau}$ for the product of edges from vertices in Γ to the top boundary of D and $z_{\beta, \Gamma}$ for the product of edges from the bottom boundary of D to Γ . We will sometimes need to replace the edge variables z_τ^j in a product with their counterparts z_β^j under the closure relations. In that case, we add β as a superscript. For example, $z_{\Gamma, \tau}^\beta$ denotes the product of z_β^j for j such that z_τ^j is outgoing from Γ . Note that $z_{\Gamma, \tau}^\beta \neq z_{\beta, \Gamma}$ in general. The former is the β -equivalents of the outgoing edges from Γ to the top boundary of D , while the latter is the edges from the bottom boundary of D into Γ . We also write $z_{\Gamma, \tau, \Delta}$ to denote the product of z_τ^j such that z_τ^j is outgoing from Γ and z_β^j is incoming to Δ . Similarly, $z_{\Gamma, \beta, \Delta}$ is the product of z_β^j such that z_τ^j is outgoing from Γ and z_β^j is incoming to Δ . These are products of edges that would go from Γ to Δ in the braid closure of the diagram D but do not in D .

In this notation, the relation in $\mathcal{N}'_I(D_\sigma)$ associated to a subset Γ of vertices in D is

$$g_\Gamma = x_{\Gamma, D \setminus \Gamma} z_{\Gamma, \tau} - x_{D \setminus \Gamma, \Gamma} z_{\beta, \Gamma}. \quad (4.4)$$

We write g_Γ^{out} and g_Γ^{in} for the first and second terms, respectively. Note that (4.4) shows the correct term order for this polynomial: the outgoing edges of the right-most, upper-most vertex in Γ determine the leading term. The quadratic relations q_i are a special case of g_Γ when Γ is a single vertex. Therefore, the set of g_Γ for all $\Gamma \subset D$ is a generating set for $\mathcal{Q}'_I(D_\sigma) + \mathcal{N}'_I(D_\sigma)$. Setting $t = 1$ in the proof of Proposition 3.3.1 of Chapter 3 shows that $\mathcal{N}'_I(D_\sigma) \subset \mathcal{Q}'_I(D_\sigma)$, so we could instead say that the polynomials g_Γ are a (highly redundant) generating set for $\mathcal{Q}'_I(D_\sigma)$.

The relation associated to a subset in $D_{\hat{\sigma}}$ is

$$n_\Gamma = x_{\Gamma, D \setminus \Gamma} z_{\Gamma, \tau, D \setminus \Gamma} - x_{D \setminus \Gamma, \Gamma} z_{D \setminus \Gamma, \beta, \Gamma}. \quad (4.5)$$

We also write n_Γ^{out} and n_Γ^{in} for the first and second terms, respectively. The term order shown in (4.5) is correct for the same reasons as above. The generators g_Γ of $\mathcal{N}'_I(D_\sigma)$ and n_Γ of $\mathcal{N}'_I(D_{\hat{\sigma}})$ are closely related: $g_\Gamma^{\text{out}} = z_{\Gamma, \tau, \Gamma} n_\Gamma^{\text{out}}$ and $g_\Gamma^{\text{in}} = z_{\Gamma, \beta, \Gamma} n_\Gamma^{\text{in}}$. In particular, for subsets that do not have any edges incident to the top or bottom boundary of D , the relations g_Γ and n_Γ are identical.

We have now established that the following is a basis for $\mathcal{Q}'_I(D_\sigma) + \mathcal{N}'_I(D_\sigma) + \mathcal{Z}$ in $\mathcal{E}'(D_\sigma)$:

$$\mathcal{Q}'_I(D_\sigma) + \mathcal{N}'_I(D_\sigma) + \mathcal{Z} = \left(\{g_\Gamma\}_{\Gamma \subset D}, z_\tau^1 - z_\beta^1, \dots, z_\tau^{b-1} - z_\beta^{b-1} \right) \quad (4.6)$$

and that we hope to add generators n_Γ for all $\Gamma \subset D$ to this basis over the course of Buchberger's algorithm. By Section 4.2, the first step to obtaining a Gröbner basis for $(\mathcal{Q}'_I(D_\sigma) + \mathcal{N}'_I(D_\sigma) + \mathcal{Z}) : (z_\tau)$ is to find a Gröbner basis for the intersection, which we can do by applying Buchberger's algorithm to

$$\mathcal{G}_0 = \left(\{\nu g_\Gamma\}_{\Gamma \subset D}, \nu z_\tau^1 - \nu z_\beta^1, \dots, \nu z_\tau^{b-1} - \nu z_\beta^{b-1}, \nu z_\tau - z_\tau \right).$$

We will now apply Buchberger's algorithm to this basis. As we compute S-polynomials, we will record the results in tables showing any propositions used and whether the result of the S-polynomial was added to the working basis.

4.4 Buchberger's algorithm: Round 1

Table 4.1 tracks the S-polynomials we compute in this section. We begin by dispensing with some S-polynomials that are easily seen to reduce to zero within the original generating set \mathcal{G}_0 .

Proposition 4.4.1. *Let $\Gamma, \Delta \subset D$ with $\Gamma \cap \Delta = \emptyset$. Assume $i \neq j$. Then*

$$S(g_\Gamma, g_\Delta) \xrightarrow{g_\Gamma, g_\Delta} 0 \quad (4.7)$$

$$S(z_\tau^i - z_\beta^i, z_\tau^j - z_\beta^j) \xrightarrow{z_\tau^i - z_\beta^i, z_\tau^j - z_\beta^j} 0 \quad (4.8)$$

and if z_τ^j is not outgoing from any vertex in Γ

$$S(g_\Gamma, z_\tau^j - z_\beta^j) \xrightarrow{g_\Gamma, z_\tau^j - z_\beta^j} 0 \quad (4.9)$$

Proof. In each case, the leading terms of the two generators in the S-polynomial have no common divisors. Since Γ and Δ do not share any vertices, and each edge is outgoing from only one vertex, Γ and Δ cannot share any outgoing edges. By Proposition 4.2.3, an S-polynomial of generators whose leading terms share no common divisors reduces to zero via the generators themselves. \square

Next, we consider S-polynomials between g_Γ and closure relations for strands on which Γ does have outgoing edges to the top boundary of D . If computed in the appropriate order, these produce a new form of subset relations that we will call the bar relations:

$$\bar{g}_\Gamma = x_{\Gamma, D \setminus \Gamma} z_{\Gamma, \tau}^\beta - x_{D \setminus \Gamma, \Gamma} z_{\beta, \Gamma},$$

where $z_{\Gamma, \tau}^\beta$ is the product of all z_β^i such that z_τ^i is outgoing from Γ . These new relations may have either term order.

Proposition 4.4.2. *Let $\Gamma \subset D$ and $z_{\Gamma,\tau} = \prod_{i=1}^p z_{\tau}^{j_i}$ be the product of edges outgoing from Γ to the top boundary of D labeled such that $j_1 > \dots > j_p$. Then for any $1 \leq k \leq p$,*

$$S(g_{\Gamma}, z_{\tau}^{j_k} - z_{\beta}^{j_k}) \xrightarrow{\{z_{\tau}^{j_i} - z_{\beta}^{j_i}\}_{i \neq k}} \bar{g}_{\Gamma} = x_{\Gamma, D \setminus \Gamma} z_{\Gamma, \tau}^{\beta} - x_{D \setminus \Gamma, \Gamma} z_{\beta, \Gamma}.$$

Either term order is possible.

Proof. First consider the case that $k = p$ and assume that $p \neq 1$. Then we have the following calculation, where the leading term from the second line until (but not including) the last line is determined by either $z_{\tau}^{j_1}$ or some divisor of $x_{\Gamma, D \setminus \Gamma}$. The leading term in the last line is unknown.

$$\begin{aligned} S(g_{\Gamma}, z_{\tau}^{j_p} - z_{\beta}^{j_p}) &= \frac{x_{\Gamma, D \setminus \Gamma} z_{\Gamma, \tau}}{x_{\Gamma, D \setminus \Gamma} z_{\Gamma, \tau}} (-x_{D \setminus \Gamma, \Gamma} z_{\beta, \Gamma}) - \frac{x_{\Gamma, D \setminus \Gamma} z_{\Gamma, \tau}}{z_{\tau}^{j_p}} (-z_{\beta}^{j_p}) \\ &= x_{\Gamma, D \setminus \Gamma} \frac{z_{\Gamma, \tau}}{z_{\tau}^{j_p}} z_{\beta}^{j_p} - x_{D \setminus \Gamma, \Gamma} z_{\beta, \Gamma} \\ \text{reduce} &- x_{\Gamma, D \setminus \Gamma} \frac{z_{\Gamma, \tau}}{z_{\tau}^{j_p} z_{\tau}^{j_{p-1}}} z_{\beta}^{j_p} (z_{\tau}^{j_{p-1}} - z_{\beta}^{j_{p-1}}) \\ &\vdots \\ \text{reduce} &- x_{\Gamma, D \setminus \Gamma} \frac{z_{\Gamma, \tau}}{z_{\tau}^{j_p} \dots z_{\tau}^{j_i}} z_{\beta}^{j_{i+1}} \dots z_{\beta}^{j_p} (z_{\tau}^{j_i} - z_{\beta}^{j_i}) \\ &\vdots \\ &= x_{\Gamma, D \setminus \Gamma} z_{\Gamma, \tau}^{\beta} - x_{D \setminus \Gamma, \Gamma} z_{\beta, \Gamma} \end{aligned}$$

While it is convenient to do the calculation in this order, it is not necessary. The leading term of g_{Γ} is determined either by some divisor of $x_{\Gamma, D \setminus \Gamma}$ or by $z_{\tau}^{j_1}$. In the first case, any S-polynomial of the form in the proposition statement will yield an expression with leading term $x_{\Gamma, D \setminus \Gamma} \frac{z_{\Gamma, \tau}}{z_{\tau}^{j_k}} z_{\beta}^{j_k}$. This expression can then be reduced by all of the other $z_{\tau}^{j_i} - z_{\beta}^{j_i}$ in any order because the factor $x_{\Gamma, D \setminus \Gamma}$ will always guarantee that the term containing $z_{\tau}^{j_i}$ leads.

In the second case, when $z_{\tau}^{j_1}$ determines the leading term, then the same argument shows that $S(g_{\Gamma}, z_{\tau}^{j_k} - z_{\beta}^{j_k})$ can be reduced as claimed for $k \neq 1$. However, when $k = 1$, there is one situation in which the term order may reverse at the first step, which is as follows. Since $z_{\tau}^{j_1}$ is the largest of the j_i , it must be the rightmost outgoing edge from its vertex (i.e. the outgoing edge nearer to the braid axis). Since $z_{\tau}^{j_1}$ determines leadership of g_{Γ} , there can be no divisor of $x_{\Gamma, D \setminus \Gamma}$ or $x_{D \setminus \Gamma, \Gamma}$ that is greater than $z_{\tau}^{j_1}$, so there can be no edge of Γ on a strand closer to the braid axis than j_1 . Therefore, the second largest divisor of either monomial in g_{Γ} must be the rightmost incoming edge of the same vertex where $z_{\tau}^{j_1}$ is the rightmost outgoing edge. This edge is a divisor of $x_{D \setminus \Gamma, \Gamma}$ and determines leadership in $S(g_{\Gamma}, z_{\tau}^{j_1} - z_{\beta}^{j_1})$. The same edge determines leadership in \bar{g}_{Γ} , which we have already produced via the more convenient order of S-polynomials. Therefore, we use \bar{g}_{Γ} to reduce

as follows.

$$\begin{aligned}
 S(g_\Gamma, z_\tau^{j_1} - z_\beta^{j_1}) &= -x_{D \setminus \Gamma, \Gamma} z_{\beta, \Gamma} + x_{\Gamma, D \setminus \Gamma} \frac{z_{\Gamma, \tau}}{z_\tau^{j_1}} z_\beta^{j_1} \\
 \text{reduce} \quad &+ \quad x_{D \setminus \Gamma, \Gamma} z_{\beta, \Gamma} - x_{\Gamma, D \setminus \Gamma} z_{\Gamma, \tau}^\beta \\
 &= \quad x_{\Gamma, D \setminus \Gamma} \left(\frac{z_{\Gamma, \tau}}{z_\tau^{j_1}} z_\beta^{j_1} - z_{\Gamma, \tau}^\beta \right)
 \end{aligned}$$

Both terms in this last expression are divisible by $z_\beta^{j_1}$, so the leading term is determined by $z_\tau^{j_2}$. Now reducing sequentially from $k = p$ down to $k = 2$ by $z_\tau^{j_k} - z_\beta^{j_k}$ produces zero. \square

The term order of a bar relation depends on the subset Γ . Whether a bar relation's leading term is a product of outgoing edges from Γ or incoming edges to Γ will change how it interacts with other subset relations throughout the algorithm.

Definition 4.4.1. *A subset $\Gamma \subset D$ is in-led if the maximal (with respect to the monomial order) edge between Γ and $D \setminus \Gamma$ in D , or incoming to Γ from the bottom boundary of D , is incoming to Γ . The subset $\Gamma \subset D$ is out-led if the maximal such edge is outgoing from Γ .*

4.4.1 S-polynomials with $\nu z_\tau - z_\tau$

Next, we examine the S-polynomials with $\nu z_\tau - z_\tau$. As the only element of \mathcal{G}_0 that is not divisible by ν , it plays a special role. Proposition 4.2.4 implies that S-polynomials among the generators divisible by ν are equal to ν times an S-polynomial of the underlying generators of $\mathcal{Q}'_I(D_\sigma) + \mathcal{N}'_I(D_\sigma) + \mathcal{Z}$ in the basis given in (4.6). Therefore, the steps of Buchberger's algorithm on \mathcal{G}_0 that do not involve $\nu z_\tau - z_\tau$ are parallel to the steps of Buchberger's algorithm applied to the basis for $\mathcal{Q}'_I(D_\sigma) + \mathcal{N}'_I(D_\sigma) + \mathcal{Z}$ in (4.6). So, in the process of running Buchberger's algorithm on \mathcal{G}_0 we incidentally produce a Gröbner basis for $\mathcal{Q}'_I(D_\sigma) + \mathcal{N}'_I(D_\sigma) + \mathcal{Z}$ itself, except that every basis element is multiplied by ν . By contrast, the S-polynomials involving $\nu z_\tau - z_\tau$ have no parallel in Buchberger's algorithm applied to a basis for $\mathcal{Q}'_I(D_\sigma) + \mathcal{N}'_I(D_\sigma) + \mathcal{Z}$. They are the only steps of the algorithm that can possibly produce generators that do not involve ν in any of their terms. The plan, of course, is to eventually discard any generator that uses ν , so the precursors to generators n_Γ that we are hoping to find in the ideal quotient will have to be produced by $\nu z_\tau - z_\tau$.

Proposition 4.4.3. *Let $f \in \mathbb{Q}[x']$ and $f = \text{LT}(f) + f'$. Then*

$$S(\nu z_\tau - z_\tau, z_\tau f) \xrightarrow{\nu z_\tau - z_\tau, z_\tau f} 0 \tag{4.10}$$

If also $\gcd(\text{LT}(f), z_\tau) = 1$, then

$$S(\nu z_\tau - z_\tau, \nu f) \xrightarrow{\nu z_\tau - z_\tau} -z_\tau f \quad (4.11)$$

$$S(\nu z_\tau - z_\tau, f) \xrightarrow{\nu z_\tau - z_\tau, f} 0. \quad (4.12)$$

If $\gcd(\text{LT}(f), z_\tau) = d \neq 1$, then

$$S(\nu z_\tau - z_\tau, \nu f) = -\frac{z_\tau}{d} (\nu f' + \text{LT}(f)) \quad (4.13)$$

$$S(\nu z_\tau - z_\tau, \nu \text{LT}(f) + f') = -\frac{z_\tau}{d} f \quad (4.14)$$

Proof. The least common multiple of the leading terms in the first three cases is $\nu z_\tau \text{LT}(f)$. In the second and third cases, this is true only because of the assumption that no term of f is divisible by ν and that the leading term of f has no divisors in common with z_τ . We calculate the first S-polynomial above as follows.

$$\begin{aligned} S(\nu z_\tau - z_\tau, z_\tau f) &= \frac{\nu z_\tau \text{LT}(f)}{\nu z_\tau} (-z_\tau) - \frac{\nu z_\tau \text{LT}(f)}{z_\tau \text{LT}(f)} (z_\tau f') \\ &= -\nu z_\tau f' - z_\tau \text{LT}(f) && \text{LT determined by } \nu \\ \text{reduce} &+ f' (\nu z_\tau - z_\tau) \\ &= -z_\tau f \\ \text{reduce} &+ z_\tau f \\ &= 0 \end{aligned}$$

The next two claims follow from similar calculations.

Finally, when $\gcd(\text{LT}(f), z_\tau) = d$, the least common multiple of the leading terms in either case is $\frac{\nu z_\tau \text{LT}(f)}{d}$. Given this, we calculate as follows.

$$\begin{aligned} S(\nu z_\tau - z_\tau, \nu f) &= \frac{\nu z_\tau \text{LT}(f)}{d \nu z_\tau} (-z_\tau) - \frac{\nu z_\tau \text{LT}(f)}{d \nu \text{LT}(f)} (\nu f') \\ &= -\frac{z_\tau}{d} \nu f' - \frac{z_\tau}{d} \text{LT}(f) && \text{LT determined by } \nu \\ &= -\frac{z_\tau}{d} (\nu f' + \text{LT}(f)) && \text{LT determined by } \nu \end{aligned}$$

The last case is similar. □

Proposition 4.4.3 has the following corollary, which explains the basic mechanism by which applications of $S(\nu z_\tau - z_\tau, -)$ create generators that will survive when we eventually discard all generators containing ν . Applied twice, $S(\nu z_\tau - z_\tau, -)$ strips any factors of z_τ^i that divide both

terms of a generator of the form νf , where f is a difference of monomials, replaces those factors with z_τ , and removes ν .

Corollary 4.4.4. *Let $f \in \mathbb{Q}[\underline{x}']$, $f = \text{LT}(f) + f'$, and $d''_\tau = \text{gcd}(\text{LT}(f), f', z_\tau)$. Then*

$$S(\nu z_\tau - z_\tau, S(\nu z_\tau - z_\tau, \nu f)) = z_\tau \frac{f}{d''_\tau}.$$

Proof. We must apply $S(\nu z_\tau - z_\tau, -)$ to the result in Equation 4.13 of Proposition 4.4.3 using the result in Equation 4.14. The greatest common divisor needed to apply Equation 4.14 is

$$\text{gcd}\left(z_\tau, \frac{z_\tau}{d} f'\right) = \frac{z_\tau}{d} \text{gcd}(d, f') = \frac{z_\tau d''_\tau}{d}.$$

Therefore,

$$S(\nu z_\tau - z_\tau, S(\nu z_\tau - z_\tau, \nu f)) = \frac{z_\tau d}{z_\tau d''_\tau} \frac{z_\tau}{d} f = \frac{z_\tau}{d''_\tau} f.$$

□

Applying $S(\nu z_\tau - z_\tau, -)$ to any of the closure relations $\nu z_\tau^i - \nu z_\beta^j$ follows the pattern of Proposition 4.4.3 in the case of a non-trivial greatest common divisor. The result always reduces to the same new generator $\nu z_\beta - z_\tau$. This new generator is not divisible by ν and has a similar form to $\nu z_\tau - z_\tau$. As we will make precise in the next section, $S(\nu z_\beta - z_\tau, -)$ behaves similarly to $S(\nu z_\tau - z_\tau, -)$.

Proposition 4.4.5. *For any $i = 1, \dots, b-1$,*

$$S(\nu z_\tau - z_\tau, \nu z_\tau^i - \nu z_\beta^i) \xrightarrow{\{\nu z_\tau^j - \nu z_\beta^j\}_{i \neq j}} \nu z_\beta - z_\tau.$$

Proof. To avoid excessive indices, we compute for the case $i = 1$. The general case is similar, and the reductions can be done in any order because the leading term will always be determined by ν .

$$\begin{aligned} S(\nu z_\tau - z_\tau, \nu z_\tau^1 - \nu z_\beta^1) &= z_\tau^2 \cdots z_\tau^{b-1} (\nu z_\beta^1 - z_\tau^1) && \text{by Prop. 4.4.3} \\ \text{reduce} &- z_\beta^1 z_\tau^3 \cdots z_\tau^{b-1} (\nu z_\tau^2 - \nu z_\beta^2) \\ &= \nu z_\beta^1 z_\beta^2 z_\tau^3 \cdots z_\tau^{b-1} - z_\tau \\ &\vdots \\ \text{reduce} &- z_\beta^1 \cdots z_\beta^{j-1} z_\tau^{j+1} \cdots z_\tau^{b-1} (\nu z_\tau^j - \nu z_\beta^j) \\ &= \nu z_\beta^1 \cdots z_\beta^j z_\tau^{j+1} \cdots z_\tau^{b-1} - z_\tau && \text{LT determined by } \nu \\ &\vdots \\ &= \nu z_\beta - z_\tau && \square \end{aligned}$$

Applying $S(\nu z_\tau - z_\tau, -)$ to a subset relation νg_Γ produces one of three outcomes. First, if none of the z_τ^j is outgoing from Γ , then by Proposition 4.4.3, $S(\nu z_\tau - z_\tau, \nu g_\Gamma)$ reduces to $z_\tau g_\Gamma$, which is the precursor to g_Γ appearing in the quotient ideal. If Γ does have at least one outgoing edge to the top boundary of D and is in-led, then $S(\nu z_\tau - z_\tau, g_\Gamma)$ reduces to zero. If Γ has at least one outgoing edge and is out-led, then $S(\nu z_\tau - z_\tau, -)$ produces a new type of generator, which has the form

$$\tilde{g}_\Gamma = \nu x_{D \setminus \Gamma, \Gamma} z_{\beta, \Gamma} z_{D \setminus \Gamma, \tau}^\beta - x_{\Gamma, D \setminus \Gamma} z_\tau.$$

We call these new generators tilde relations and add them to the working basis. Because they have only one term divisible by ν , these generators behave similarly to $\nu z_\tau - z_\tau$ and $\nu z_\beta - z_\tau$. We consider their behavior in detail in Section 4.5.2

Proposition 4.4.6. *Let $\Gamma \subset D$. If $z_{\Gamma, \tau} = 1$, then*

$$S(\nu z_\tau - z_\tau, \nu g_\Gamma) \xrightarrow{\nu z_\tau - z_\tau, g_\Gamma} z_\tau g_\Gamma. \quad (4.15)$$

If $z_{\Gamma, \tau} \neq 1$, then

$$S(\nu z_\tau - z_\tau, \nu g_\Gamma) \xrightarrow{\{z_\tau^j - z_\beta^j\}_{j \in D \setminus \Gamma}, \nu \bar{g}_\Gamma, \nu z_\beta - z_\tau} 0 \text{ if } \Gamma \text{ is in-led and} \quad (4.16)$$

$$S(\nu z_\tau - z_\tau, \nu g_\Gamma) \xrightarrow{\{z_\tau^j - z_\beta^j\}_{j \in D \setminus \Gamma}} \nu x_{D \setminus \Gamma, \Gamma} z_{\beta, \Gamma} z_{D \setminus \Gamma, \tau}^\beta - x_{\Gamma, D \setminus \Gamma} z_\tau = \tilde{g}_\Gamma \text{ if } \Gamma \text{ is out-led.} \quad (4.17)$$

Proof. In the first case, the leading terms of g_Γ and $\nu z_\tau - z_\tau$ have no common divisor. The result then follows directly from Proposition 4.4.3.

In the second and third cases, the calculation begins as follows.

$$\begin{aligned} S(\nu z_\tau - z_\tau, \nu g_\Gamma) &= \frac{\nu z_\tau x_{\Gamma, D \setminus \Gamma}}{\nu z_\tau} (-z_\tau) - \frac{\nu z_\tau x_{\Gamma, D \setminus \Gamma}}{\nu x_{\Gamma, D \setminus \Gamma} z_{\Gamma, \tau}} (-\nu x_{D \setminus \Gamma, \Gamma} z_{\beta, \Gamma}) \\ &= \nu z_{D \setminus \Gamma, \tau} x_{D \setminus \Gamma, \Gamma} z_{\beta, \Gamma} - x_{\Gamma, D \setminus \Gamma} z_\tau \quad \text{LT det. by } \nu \end{aligned}$$

This expression can be reduced by $\nu z_\tau^j - \nu z_\beta^j$ for all z_τ^j that divide $z_{D \setminus \Gamma, \tau}$. The term order will never change because the expression above has ν in only one term, while the expressions we reduce by have ν in both terms. These reductions produce

$$\tilde{g}_\Gamma = \nu x_{D \setminus \Gamma, \Gamma} z_{\beta, \Gamma} z_{D \setminus \Gamma, \tau}^\beta - x_{\Gamma, D \setminus \Gamma} z_\tau$$

If Γ is in-led, then we may use $\nu \bar{g}_\Gamma$ to reduce further.

$$\begin{aligned} &= \nu z_{D \setminus \Gamma, \tau}^\beta x_{D \setminus \Gamma, \Gamma} z_{\beta, \Gamma} - x_{\Gamma, D \setminus \Gamma} z_\tau \\ \text{reduce} \quad &- z_{D \setminus \Gamma, \tau}^\beta \left(\nu x_{D \setminus \Gamma, \Gamma} z_{\beta, \Gamma} - \nu x_{\Gamma, D \setminus \Gamma} z_{\Gamma, \tau}^\beta \right) \\ &= \nu x_{\Gamma, D \setminus \Gamma} z_{\Gamma, \tau}^\beta z_{D \setminus \Gamma, \tau}^\beta - x_{\Gamma, D \setminus \Gamma} z_\tau \\ &= x_{\Gamma, D \setminus \Gamma} (\nu z_\beta - z_\tau), \end{aligned}$$

which reduces to zero by $\nu z_\beta - z_\tau$. \square

4.4.2 S-polynomials among subset relations

The final S-polynomial to check in Round 1 is $S(\nu g_\Gamma, \nu g_\Delta)$ when $\Gamma \cap \Delta \neq \emptyset$. We will have to do similar calculations in later rounds of Buchberger's algorithm, so we establish a general principle that will allow us to tackle the internal edges separately from the boundary edges.

Proposition 4.4.7. *Let $f_x, f'_x, f_z, f'_z, g_x, g'_x, g_z, g'_z \in \mathbb{Q}[\underline{x}]$ be monomials with the property that any monomial with an x subscript is relatively prime to any monomial with a z subscript. Let $S(f_x + f'_x, g_x + g'_x)_1$ and $S(f_x + f'_x, g_x + g'_x)_2$ denote the first and second terms of $S(f_x + f'_x, g_x + g'_x)$ as written in the definition of S-polynomial in Section 4.2, not necessarily with respect to the monomial ordering, and similarly for $S(f_z + f'_z, g_z + g'_z)$. Then*

$$\begin{aligned} S(f_x f_z + f'_x f'_z, g_x g_z + g'_x g'_z) &= S(f_x + f'_x, g_x + g'_x)_1 S(f_z + f'_z, g_z + g'_z)_1 \\ &\quad - S(f_x + f'_x, g_x + g'_x)_2 S(f_z + f'_z, g_z + g'_z)_2 \\ &\quad \xrightarrow{S(f_x + f'_x, g_x + g'_x), S(f_z + f'_z, g_z + g'_z)} 0 \end{aligned}$$

Proof. The assumptions about greatest common divisors among the monomials mean that

$$\text{lcm}(f_x f_z, g_x g_z) = \frac{f_x f_z g_x g_z}{\text{gcd}(f_x, g_x) \text{gcd}(f_z, g_z)} = \text{lcm}(f_x, g_x) \text{lcm}(f_z, g_z).$$

The S-polynomial calculations proceed as follows.

$$\begin{aligned} S(f_x f_z + f'_x f'_z, g_x g_z + g'_x g'_z) &= \\ &\quad \frac{g_x g_z}{\text{gcd}(f_x, g_x) \text{gcd}(f_z, g_z)} f'_x f'_z - \frac{f_x f_z}{\text{gcd}(f_x, g_x) \text{gcd}(f_z, g_z)} g'_x g'_z \\ &\quad - \frac{g_x}{\text{gcd}(f_x, g_x)} f'_x \frac{g_z}{\text{gcd}(f_z, g_z)} f'_z - \frac{f_x}{\text{gcd}(f_x, g_x)} g'_x \frac{f_z}{\text{gcd}(f_z, g_z)} g'_z \end{aligned}$$

The term order in this expression is not clear. However, the first term is a product of the first terms of $S(f_x + f'_x, g_x + g'_x)$ and $S(f_z + f'_z, g_z + g'_z)$ and the second term is a product of their second terms, assuming everything is written as in Definition 4.2.3, not necessarily with respect to the monomial ordering. Regardless of the correct term order, Proposition 4.2.5 shows that expressions of this form reduce to zero by their constituent parts. \square

Proposition 4.4.8. *Let $\Gamma, \Delta \subset D$. Assume term orders of the S-polynomial input are as written. Then*

$$S(x_{\Gamma, D \setminus \Gamma} - x_{D \setminus \Gamma, \Gamma}, x_{\Delta, D \setminus \Delta} - x_{D \setminus \Delta, \Delta}) = x_{D \setminus (\Gamma \cup \Delta), \Gamma \cap \Delta} \left(x_{\Delta \setminus (\Gamma \cap \Delta)}^{\text{out}} x_{\Gamma \setminus (\Gamma \cap \Delta)}^{\text{in}} - x_{\Gamma \setminus (\Gamma \cap \Delta)}^{\text{out}} x_{\Delta \setminus (\Gamma \cap \Delta)}^{\text{in}} \right),$$

where the term order of the result is unknown in general.

Proof. This proof is mainly a long calculation. The outcome relies on the fact that least common multiples and greatest common divisors of monomials behave in the same way as union and intersection of subsets. The greatest common divisor of the leading terms is $x_{\Gamma \cap \Delta, D \setminus (\Gamma \cup \Delta)}$ so the least common multiple is

$$\frac{x_{\Gamma, D \setminus \Gamma} x_{\Delta, D \setminus \Delta}}{x_{\Gamma \cap \Delta, D \setminus (\Gamma \cup \Delta)}}.$$

The least common multiple divided by each leading term is

$$\begin{aligned} \frac{x_{\Gamma, D \setminus \Gamma} x_{\Delta, D \setminus \Delta}}{x_{\Gamma \cap \Delta, D \setminus (\Gamma \cup \Delta)} x_{\Gamma, D \setminus \Gamma}} &= x_{\Delta \setminus (\Gamma \cap \Delta), D \setminus (\Gamma \cup \Delta)} x_{\Delta, \Gamma \setminus (\Gamma \cap \Delta)} \\ \frac{x_{\Gamma, D \setminus \Gamma} x_{\Delta, D \setminus \Delta}}{x_{\Gamma \cap \Delta, D \setminus (\Gamma \cup \Delta)} x_{\Delta, D \setminus \Delta}} &= x_{\Gamma \setminus (\Gamma \cap \Delta), D \setminus (\Gamma \cup \Delta)} x_{\Gamma, \Delta \setminus (\Gamma \cap \Delta)} \end{aligned}$$

We may now compute the S-polynomial.

$$S(g_\Gamma, g_\Delta) = x_{\Delta \setminus (\Gamma \cap \Delta), D \setminus (\Gamma \cup \Delta)} x_{\Delta, \Gamma \setminus (\Gamma \cap \Delta)} x_{D \setminus \Gamma, \Gamma} + x_{\Gamma \setminus (\Gamma \cap \Delta), D \setminus (\Gamma \cup \Delta)} x_{\Gamma, \Delta \setminus (\Gamma \cap \Delta)} x_{D \setminus \Delta, \Delta},$$

where term order is unknown. Expanding, then regrouping produces the form claimed in the proposition. Term order is unknown throughout.

$$\begin{aligned} &S(x_{\Gamma, D \setminus \Gamma} - x_{D \setminus \Gamma, \Gamma}, x_{\Delta, D \setminus \Delta} - x_{D \setminus \Delta, \Delta}) \\ &= x_{\Delta \setminus (\Gamma \cap \Delta), D \setminus (\Gamma \cup \Delta)} x_{\Delta \setminus (\Gamma \cap \Delta), \Gamma \setminus (\Gamma \cap \Delta)} x_{\Gamma \cap \Delta, \Gamma \setminus (\Gamma \cap \Delta)} \\ &\quad \cdot x_{\Delta \setminus (\Gamma \cap \Delta), \Gamma \setminus (\Gamma \cap \Delta)} x_{D \setminus (\Gamma \cup \Delta), \Gamma \setminus (\Gamma \cap \Delta)} x_{\Delta \setminus (\Gamma \cap \Delta), \Gamma \cap \Delta} x_{D \setminus (\Gamma \cup \Delta), \Gamma \cap \Delta} \\ &+ x_{\Gamma \setminus (\Gamma \cap \Delta), D \setminus (\Gamma \cup \Delta)} x_{\Gamma \setminus (\Gamma \cap \Delta), \Delta \setminus (\Gamma \cap \Delta)} x_{\Gamma \cap \Delta, \Delta \setminus (\Gamma \cap \Delta)} \\ &\quad \cdot x_{\Gamma \setminus (\Gamma \cap \Delta), \Delta \setminus (\Gamma \cap \Delta)} x_{D \setminus (\Gamma \cup \Delta), \Delta \setminus (\Gamma \cap \Delta)} x_{\Gamma \setminus (\Gamma \cap \Delta), \Gamma \cap \Delta} x_{D \setminus (\Gamma \cup \Delta), \Gamma \cap \Delta} \\ &= x_{D \setminus (\Gamma \cup \Delta), \Gamma \cap \Delta} (x_{\Delta \setminus (\Gamma \cap \Delta), D \setminus \Delta} x_{\Gamma \cap \Delta, \Gamma \setminus (\Gamma \cap \Delta)} x_{D \setminus \Gamma, \Gamma \setminus (\Gamma \cap \Delta)} x_{\Delta \setminus (\Gamma \cap \Delta), \Gamma \cap \Delta} \\ &\quad - x_{\Gamma \setminus (\Gamma \cap \Delta), D \setminus \Gamma} x_{\Gamma \cap \Delta, \Delta \setminus (\Gamma \cap \Delta)} x_{D \setminus \Delta, \Delta \setminus (\Gamma \cap \Delta)} x_{\Gamma \setminus (\Gamma \cap \Delta), \Gamma \cap \Delta}) \\ &= x_{D \setminus (\Gamma \cup \Delta), \Gamma \cap \Delta} \left(x_{\Delta \setminus (\Gamma \cap \Delta)}^{\text{out}} x_{\Gamma \setminus (\Gamma \cap \Delta)}^{\text{in}} - x_{\Gamma \setminus (\Gamma \cap \Delta)}^{\text{out}} x_{\Delta \setminus (\Gamma \cap \Delta)}^{\text{in}} \right) \quad \square \end{aligned}$$

The calculation for the boundary edges is similar.

Proposition 4.4.9. *Let $\Gamma, \Delta \subset D$. Assume term orders of the S-polynomial input are as written.*

Then

$$S(z_{\Gamma, \tau} - z_{\beta, \Gamma}, z_{\Delta, \tau} - z_{\beta, \Delta}) = z_{\beta, \Gamma \cap \Delta} (z_{\Delta \setminus (\Gamma \cap \Delta), \tau} z_{\beta, \Gamma \setminus (\Gamma \cap \Delta)} + z_{\Gamma \setminus (\Gamma \cap \Delta), \tau} z_{\beta, \Delta \setminus (\Gamma \cap \Delta)}), \quad (4.18)$$

where the term order of the result is unknown in general.

Proof. The least common multiple of the leading terms is $z_{\Gamma \cup \Delta, \tau}$, so the S-polynomial calculation is as follows.

$$\begin{aligned} S(z_{\Gamma, \tau} - z_{\beta, \Gamma}, z_{\Delta, \tau} - z_{\beta, \Delta}) &= \frac{z_{\Gamma \cup \Delta, \tau}}{z_{\Gamma, \tau}} (-z_{\beta, \Gamma}) - \frac{z_{\Gamma \cup \Delta, \tau}}{z_{\Delta, \tau}} (-z_{\beta, \Delta}) \\ &= -z_{\Delta \setminus (\Gamma \cap \Delta), \tau} z_{\beta, \Gamma} + z_{\Gamma \setminus (\Gamma \cap \Delta), \tau} z_{\beta, \Delta} \end{aligned}$$

Factoring out $z_{\beta, \Gamma \cap \Delta}$ from both terms finishes the calculation. \square

Combining the calculations in Propositions 4.4.8 and 4.4.9 with the general principle in Proposition 4.4.7, we obtain $S(g_\Gamma, g_\Delta)$ and see that it can always be reduced to zero.

Corollary 4.4.10. *Let $\Gamma, \Delta \subset D$. Then*

$$S(g_\Gamma, g_\Delta) = x_{D \setminus (\Gamma \cup \Delta), \Gamma \cap \Delta} z_{\beta, \Gamma \cap \Delta} \left(g_{\Delta \setminus (\Gamma \cap \Delta)}^{\text{out}} g_{\Gamma \setminus (\Gamma \cap \Delta)}^{\text{in}} - g_{\Gamma \setminus (\Gamma \cap \Delta)}^{\text{out}} g_{\Delta \setminus (\Gamma \cap \Delta)}^{\text{in}} \right) \quad (4.19)$$

$$\xrightarrow{g_{\Gamma \setminus (\Gamma \cap \Delta)}, g_{\Delta \setminus (\Gamma \cap \Delta)}} 0 \quad (4.20)$$

Proof. Combine the previous two calculations to see that

$$\begin{aligned} S(g_\Gamma, g_\Delta) &= x_{D \setminus (\Gamma \cup \Delta), \Gamma \cap \Delta} z_{\beta, \Gamma \cap \Delta} (x_{\Delta \setminus (\Gamma \cap \Delta)}^{\text{out}} x_{\Gamma \setminus (\Gamma \cap \Delta)}^{\text{in}} z_{\Delta \setminus (\Gamma \cap \Delta), \tau} z_{\beta, \Gamma \setminus (\Gamma \cap \Delta)} \\ &\quad - x_{\Gamma \setminus (\Gamma \cap \Delta)}^{\text{out}} x_{\Delta \setminus (\Gamma \cap \Delta)}^{\text{in}} z_{\Gamma \setminus (\Gamma \cap \Delta), \tau} z_{\beta, \Delta \setminus (\Gamma \cap \Delta)}) \\ &= x_{D \setminus (\Gamma \cup \Delta), \Gamma \cap \Delta} z_{\beta, \Gamma \cap \Delta} \left(g_{\Delta \setminus (\Gamma \cap \Delta)}^{\text{out}} g_{\Gamma \setminus (\Gamma \cap \Delta)}^{\text{in}} - g_{\Gamma \setminus (\Gamma \cap \Delta)}^{\text{out}} g_{\Delta \setminus (\Gamma \cap \Delta)}^{\text{in}} \right) \end{aligned}$$

The term order here is unknown, but Proposition 4.2.5 shows that the expression reduces to zero either way. \square

Table 4.1: S-polynomials Round 1

$S(-, -)$	Result	Prop.	Action
$S(\nu g_\Gamma, \nu g_\Delta)$	0	Prop. 4.2.4 and 4.4.1 or 4.4.10	none
$S(\nu z_\tau^i - \nu z_\beta^i, \nu z_\tau^j - \nu z_\beta^j)$	0	Prop. 4.2.4 and 4.4.1	none
$S(\nu g_\Gamma, \nu z_\tau^j - \nu z_\beta^j)$	0 or $\nu \bar{g}_\Gamma$	Prop. 4.2.4 and 4.4.1 or 4.4.2	in \mathcal{G}_1
$S(\nu g_\Gamma, \nu z_\tau - z_\tau)$	$z_\tau g_\Gamma$ or 0 or \tilde{g}_Γ	Prop. 4.4.6	in \mathcal{G}_1
$S(\nu z_\tau^j - \nu z_\beta^j, \nu z_\tau - z_\tau)$	$\nu z_\beta - z_\tau$	Prop. 4.4.5	in \mathcal{G}_1

At the end of round 1, we have the following working basis:

$$\mathcal{G}_1 = \mathcal{G}_0 + (\nu \bar{g}_\Gamma, z_\tau g_\Gamma, \tilde{g}_\Gamma, \nu z_\beta - z_\tau),$$

where $\nu \bar{g}_\Gamma$ occurs only when $z_{\Gamma, \tau} \neq 1$, $z_\tau g_\Gamma$ occurs only when $z_{\Gamma, \tau} = 1$, and \tilde{g}_Γ occurs only when Γ is out-led and $z_{\Gamma, \tau} \neq 1$.

4.5 Buchberger's algorithm: Round 2

Having added several new types of generators in round 1, we must now compute a new round of S-polynomials. We compute some of these in round 2 and postpone others to round 3, but keep track of all of the computations in Tables 4.3 and 4.4.

Some of the necessary computations are immediate from Proposition 4.2.4 and computations from Round 1. Leading terms of \bar{g}_Γ are never divisible by any z_τ^j , so we can use Propositions 4.2.3 and 4.2.4 together to see that \bar{g}_Γ pairs trivially with any closure relation. For the same reason, Proposition 4.2.4 and Proposition 4.4.3 together show that $S(\nu z_\tau - z_\tau, \bar{g}_\Gamma) = z_\tau \bar{g}_\Gamma$. We also apply Proposition 4.4.3 to show that $S(z_\tau g_\Gamma, \nu z_\tau - z_\tau) = 0$.

4.5.1 Properties of $\nu z_\beta - z_\tau$ and their applications

The new generator $\nu z_\beta - z_\tau$ has analogous properties to $\nu z_\tau - z_\tau$, which we record in the following proposition.

Proposition 4.5.1. *Let $f \in \mathbb{Q}[\underline{x}']$ and $f = \text{LT}(f) + f'$. Then*

$$S(\nu z_\beta - z_\tau, z_\tau f) \xrightarrow{\nu z_\tau - z_\tau, \{z_\tau(z_\tau^j - z_\beta^j)\}_{j=1}^{b-1}, z_\tau f} 0$$

If also $\gcd(\text{LT}(f), z_\beta) = 1$, then

$$S(\nu z_\beta - z_\tau, \nu f) \xrightarrow{\nu z_\beta - z_\tau} -z_\tau f \quad (4.21)$$

$$S(\nu z_\beta - z_\tau, f) \xrightarrow{\nu z_\beta - z_\tau, f} 0 \quad (4.22)$$

If $\gcd(\text{LT}(f), z_\beta) = d \neq 1$, then

$$S(\nu z_\beta - z_\tau, \nu f) = -\frac{z_\beta}{d} \nu f' - z_\tau \frac{\text{LT}(f)}{d} \quad (4.23)$$

$$S(\nu z_\beta - z_\tau, \nu \text{LT}(f) + f') = -\frac{z_\tau}{d} \text{LT}(f) - \frac{z_\beta}{d} f' \quad (4.24)$$

Proof. For the first S-polynomial, let $d = \gcd(z_\beta, \text{LT}(f))$, which may be 1. Compute as follows.

$$\begin{aligned} S(\nu z_\beta - z_\tau, z_\tau f) &= \frac{\nu z_\beta z_\tau \text{LT}(f)}{d \nu z_\beta} (-z_\tau) - \frac{\nu z_\beta z_\tau \text{LT}(f)}{d z_\tau \text{LT}(f)} (z_\tau f') \\ &= -\nu z_\tau \frac{z_\beta}{d} f' - z_\tau^2 \frac{\text{LT}(f)}{d} && \text{LT determined by } \nu \\ \text{reduce} &+ \frac{z_\beta}{d} f' (\nu z_\tau - z_\tau) \\ &= -z_\tau^2 \frac{\text{LT}(f)}{d} - z_\tau \frac{z_\beta}{d} f' && \text{LT determined by } z_\tau > z_\beta, \text{LT}(f) > f' \\ &\vdots \end{aligned}$$

$$\begin{aligned}
\text{reduce} \quad & + \frac{\text{LT}(f)}{d} \left(z_\beta^1 \cdots z_\beta^{j-1} z_\tau^{j+1} \cdots z_\tau^{b-1} \right) z_\tau \left(z_\tau^j - z_\beta^j \right) \\
& = \left(z_\beta^1 \cdots z_\beta^j z_\tau^{j+1} \cdots z_\tau^{b-1} \right) z_\tau \frac{\text{LT}(f)}{d} - z_\tau \frac{z_\beta^j}{d} f' \\
& \quad \vdots \\
& = -z_\tau \frac{z_\beta^j}{d} f,
\end{aligned}$$

which reduces to zero by $z_\tau f$.

For the second and third S-polynomials, the least common multiple of the leading monomials is $\nu z_\beta \text{LT}(f)$. Then

$$\begin{aligned}
S(\nu z_\beta - z_\tau, \nu f) &= \frac{\nu z_\beta \text{LT}(f)}{\nu z_\beta} (-z_\tau) - \frac{\nu z_\beta \text{LT}(f)}{\nu \text{LT}(f)} (\nu f') \\
&= -\nu z_\beta f' - z_\tau \text{LT}(f) && \text{LT determined by } \nu \\
\text{reduce} \quad & + f' (\nu z_\beta - z_\tau) \\
&= -z_\tau f
\end{aligned}$$

and

$$\begin{aligned}
S(\nu z_\beta - z_\tau, f) &= \frac{\nu z_\beta \text{LT}(f)}{\nu z_\beta} (-z_\tau) - \frac{\nu z_\beta \text{LT}(f)}{\text{LT}(f)} (f') \\
&= -\nu z_\beta f' - z_\tau \text{LT}(f) && \text{LT determined by } \nu \\
\text{reduce} \quad & + f' (\nu z_\beta - z_\tau) \\
&= -z_\tau f,
\end{aligned}$$

which reduces to zero by $z_\tau f$.

The computation of the S-polynomial in the case where $\gcd(\text{LT}(f), z_\beta) \neq 1$ is the same except for the additional factor of $\frac{1}{d}$. The corresponding reductions are impossible because the leading term of the S-polynomial is no longer divisible by νz_β .

$$\begin{aligned}
S(\nu z_\beta - z_\tau, \nu f) &= \frac{\nu z_\beta \text{LT}(f)}{d} \frac{1}{\nu z_\beta} (-z_\tau) - \frac{\nu z_\beta \text{LT}(f)}{d} \frac{1}{\nu \text{LT}(f)} \nu f' \\
&= -z_\tau \frac{\text{LT}(f)}{d} - \frac{z_\beta}{d} \nu f'
\end{aligned}$$

Since ν determines the leading term, the term order is as stated in the Proposition. The computation for the last case is similar. \square

Proposition 4.5.1 has an immediate corollary that explains the role of $\nu z_\beta - z_\tau$ in our application of Buchberger's algorithm. Applied twice, $S(\nu z_\beta - z_\tau, -)$ strips factors of z_β^i that divide both terms of

a generator νf that is a difference of monomials, replaces them with z_τ , and removes ν . Together, $\nu z_\tau - z_\tau$ and $\nu z_\beta - z_\tau$ are the main tools we have to create new generators that survive to be in the Gröbner basis of the intersection $(\mathcal{Q}'_I(D_\sigma) + \mathcal{N}'_I(D_\sigma) + \mathcal{Z}) \cap (z_\tau)$.

Corollary 4.5.2. *Let $f \in \mathbb{Q}[\underline{x}']$ be a polynomial with two terms and $d''_\beta = \gcd(\text{LT}(f), f', z_\beta)$. Then*

$$S(\nu z_\beta - z_\tau, S(\nu z_\beta - z_\tau, \nu f)) = z_\tau \frac{f}{d''_\beta}.$$

Proposition 4.5.1 also allows us to immediately take care of a few S-polynomials:

$$S(\nu z_\beta - z_\tau, \nu z_\tau^j - \nu z_\beta^j) = z_\tau (z_\tau^j - z_\beta^j)$$

must appear in \mathcal{G}_2 . This allows us to use freely the first fact in Proposition 4.5.1, which relies on the presence of $z_\tau (z_\tau^j - z_\beta^j)$ in our basis. Proposition 4.5.1 now allows us to immediately take care of $S(\nu z_\beta - z_\tau, -)$ applied to any generator whose leading term is not divisible by z_β^j for any j and any generator that is divisible by z_τ . Since the leading term of g_Γ is a product of outgoing edges for any Γ , it is not divisible by any z_β^j . Therefore, we obtain $z_\tau g_\Gamma$ for any subset $\Gamma \subset D$.

Applying $S(\nu z_\beta - z_\tau, -)$ to the bar relations \bar{g}_Γ for in-led Γ produces $z_\tau \bar{g}_\Gamma$ in the cases where Γ has no incoming edges from the bottom boundary of D . We have already added these generators to \mathcal{G}_2 since they also appeared via the application of $S(\nu z_\tau - z_\tau, -)$ to the same bar relations. When Γ is in-led and does have incoming edges from the bottom boundary, $S(\nu z_\beta - z_\tau, -)$ produces a tilde relation \tilde{g}_Γ that is not yet in the working basis. When Γ is out-led, it also produces \tilde{g}_Γ , but that generator is already in \mathcal{G}_1 in all such cases.

Proposition 4.5.3. *Let Γ have at least one outgoing edge to the top boundary of D . If Γ is in-led and has at least one incoming edge from the bottom boundary of D , then*

$$\begin{aligned} S(\nu z_\beta - z_\tau, \nu \bar{g}_\Gamma) &= \nu x_{\Gamma, D \setminus \Gamma} z_{\beta, D \setminus \Gamma} z_{\Gamma, \tau}^\beta - x_{D \setminus \Gamma, \Gamma} z_\tau \\ &:= \tilde{g}_\Gamma. \end{aligned}$$

If Γ is out-led, then

$$S(\nu z_\beta - z_\tau, \nu \bar{g}_\Gamma) = \tilde{g}_\Gamma \in \mathcal{G}_1$$

Proof. If Γ is in-led, \bar{g}_Γ has the form

$$\bar{g}_\Gamma = x_{D \setminus \Gamma, \Gamma} z_{\beta, \Gamma} - x_{\Gamma, D \setminus \Gamma} z_{\Gamma, \tau}^\beta,$$

where $z_{\beta, \Gamma} \neq 1$. By Proposition 4.5.1 in the case that $\gcd(\text{LT}(f), z_\beta) \neq 1$, we have

$$\begin{aligned} S(\nu z_\beta - z_\tau, \nu \bar{g}_\Gamma) &= -\frac{z_\beta}{z_{\beta, \Gamma}} \nu x_{\Gamma, D \setminus \Gamma} z_{\Gamma, \tau}^\beta + z_\tau \frac{x_{D \setminus \Gamma, \Gamma} z_{\beta, \Gamma}}{z_{\beta, \Gamma}} \\ &= -\nu x_{\Gamma, D \setminus \Gamma} z_{\beta, D \setminus \Gamma} z_{\Gamma, \tau}^\beta + z_\tau x_{D \setminus \Gamma, \Gamma}, \end{aligned}$$

which we have defined to be \tilde{g}_Γ .

If Γ is out-led, then \bar{g}_Γ has the form

$$\bar{g}_\Gamma = x_{\Gamma, D \setminus \Gamma} z_{\Gamma, \tau}^\beta - x_{D \setminus \Gamma, \Gamma} z_{\beta, \Gamma}.$$

By Proposition 4.5.1,

$$\begin{aligned} S(\nu z_\beta - z_\tau, \nu \bar{g}_\Gamma) &= -\frac{z_\beta}{z_{\Gamma, \tau}^\beta} \nu x_{D \setminus \Gamma, \Gamma} z_{\beta, \Gamma} + z_\tau \frac{x_{\Gamma, D \setminus \Gamma} z_{\Gamma, \tau}^\beta}{z_{\Gamma, \tau}^\beta} \\ &= -\nu x_{D \setminus \Gamma, \Gamma} z_{D \setminus \Gamma, \tau}^\beta z_{\beta, \Gamma} + z_\tau x_{\Gamma, D \setminus \Gamma} \end{aligned}$$

This is exactly \tilde{g}_Γ as defined in Section 4.4.1 and the subsets for which Γ is out-led and \bar{g}_Γ is in \mathcal{G}_1 are exactly the subsets for which \tilde{g}_Γ is in \mathcal{G}_1 . Therefore, we may reduce $S(\nu z_\beta - z_\tau, \bar{g}_\Gamma)$ to zero in this case. \square

Finally, we may describe S-polynomials between $\nu z_\beta - z_\tau$ and \tilde{g}_Γ for either type of \tilde{g}_Γ relation. The two versions of \tilde{g}_Γ were obtained by applying $S(\nu z_\tau - z_\tau, -)$ to out-led νg_Γ and $S(\nu z_\beta - z_\tau, -)$ to in-led $\nu \bar{g}_\Gamma$. When we apply $S(\nu z_\beta - z_\tau, -)$ to \tilde{g}_Γ for in-led Γ , we may instead think of applying $S(\nu z_\beta - z_\tau, -)$ twice to some \bar{g}_Γ . In that case, Corollary 4.5.2 says that the effect will be to remove any factors of z_β^i that occur in both terms of \bar{g}_Γ . Regardless of term order, \bar{g}_Γ factors as

$$\bar{g}_\Gamma = x_{\Gamma, D \setminus \Gamma} z_{\Gamma, \tau}^\beta - x_{D \setminus \Gamma, \Gamma} z_{\beta, \Gamma} = z_{\Gamma, \beta, \Gamma} (x_{\Gamma, D \setminus \Gamma} z_{\Gamma, \beta, D \setminus \Gamma} - x_{D \setminus \Gamma, \Gamma} z_{D \setminus \Gamma, \beta, \Gamma}) = z_{\Gamma, \beta, \Gamma} \bar{n}_\Gamma.$$

In the second case, we apply $S(\nu z_\beta - z_\tau, -)$ to $S(\nu z_\tau - z_\tau, g_\Gamma)$. The result does not follow directly from Corollary 4.5.2, but it is a straightforward calculation to see that we again obtain \bar{n}_Γ . Therefore, $S(\nu z_\beta - z_\tau, \tilde{g}_\Gamma) = z_\tau \bar{n}_\Gamma$ for any Γ for which \tilde{g}_Γ occurs in the working basis. Therefore, we add $z_\tau \bar{n}_\Gamma$ to the working basis for all of the same Γ for which we have \tilde{g}_Γ .

Our working basis now contains the following generators.

$$\mathcal{G}'_1 = (\nu g_\Gamma, z_\tau g_\Gamma, \nu \bar{g}_\Gamma, z_\tau \bar{g}_\Gamma, \tilde{g}_\Gamma, z_\tau \bar{n}_\Gamma, \nu z_\tau^j - \nu z_\beta^j, z_\tau (z_\tau^j - z_\beta^j), \nu z_\tau - z_\tau, \nu z_\beta - z_\tau),$$

where $1 \leq j \leq b-1$, $\nu \bar{g}_\Gamma$ and $z_\tau \bar{g}_\Gamma$ occur only when $z_{\Gamma, \tau} \neq 1$, and \tilde{g}_Γ and $z_\tau \bar{n}_\Gamma$ occur only when Γ is out-led and $z_{\Gamma, \tau} \neq 1$ or Γ is in-led and $z_{\Gamma, \tau} \neq 1, z_{\beta, \Gamma} \neq 1$.

4.5.2 More S-polynomials among subset relations

Our next task is to establish a better understanding of how the subset relations g_Γ , \bar{g}_Γ , and \tilde{g}_Γ behave. As previously mentioned, the key property of a subset in this respect is whether its ingoing or outgoing edges determine the term order in its associated bar relation. Table 4.2 summarizes the different types of subset relations we have encountered.

Table 4.2: Types of Subset Relations

Type	Γ out-led	Γ in-led
g_Γ	$x_{\Gamma, D \setminus \Gamma} z_{\Gamma, \tau} - x_{D \setminus \Gamma, \Gamma} z_{\beta, \Gamma}$	$x_{\Gamma, D \setminus \Gamma} z_{\Gamma, \tau} - x_{D \setminus \Gamma, \Gamma} z_{\beta, \Gamma}$
\bar{g}_Γ	$x_{\Gamma, D \setminus \Gamma} z_{\Gamma, \tau}^\beta - x_{D \setminus \Gamma, \Gamma} z_{\beta, \Gamma}$	$x_{D \setminus \Gamma, \Gamma} z_{\beta, \Gamma} - x_{\Gamma, D \setminus \Gamma} z_{\Gamma, \tau}^\beta$
\tilde{g}_Γ	$\nu x_{D \setminus \Gamma, \Gamma} z_{\beta, \Gamma} z_{D \setminus \Gamma, \tau}^\beta - x_{\Gamma, D \setminus \Gamma} z_\tau$	$\nu x_{\Gamma, D \setminus \Gamma} z_{\beta, D \setminus \Gamma} z_{\Gamma, \tau}^\beta - x_{D \setminus \Gamma, \Gamma} z_\tau$

In the original subset relations g_Γ , the leading term is always the product of outgoing edges from Γ , regardless of any properties of Γ . For the bar relations \bar{g}_Γ , the leading term is a product of incoming (resp. outgoing) edges if Γ is in-led (resp. out-led), as defined in Section 4.4. The basis \mathcal{G}'_1 has \bar{g}_Γ only for those subsets Γ that have at least one edge outgoing to the top boundary of D , but for any other subset $g_\Gamma = \bar{g}_\Gamma$ anyway. We will think of the tilde relation \tilde{g}_Γ as being artificially term-reversed. If Γ is out-led, then the leading term of \tilde{g}_Γ is a product of incoming edges; if Γ is in-led, then the leading term of \tilde{g}_Γ is a product of outgoing edges. The term reversal (compared to \bar{g}_Γ) occurs because the tilde relations are obtained from other subset relations by applying $S(\nu z_\tau - z_\tau, -)$ or $S(\nu z_\beta - z_\tau, -)$ once. These S-polynomials always remove ν from a leading term. We will not need to consider \tilde{g}_Γ for all subsets Γ , since sometimes $S(\nu z_\tau - z_\tau, -)$ or $S(\nu z_\beta - z_\tau, -)$ applied to a plain or bar relation produces something that reduces to zero immediately. Specifically, we need only consider tilde relations for subsets Γ that are (i) out-led with $z_{\Gamma, \tau}^\beta \neq 1$ or (ii) in-led with $z_{\Gamma, \tau}^\beta \neq 1$ and $z_{\beta, \Gamma} \neq 1$, which are exactly those contained in \mathcal{G}'_1 .

At this point, we can fill in a few miscellaneous rows of Tables 4.3 and 4.4. Knowing that $z_\tau (z_\tau^j - z_\beta^j)$ and $z_\tau g_\Gamma$ for any Γ are in \mathcal{G}'_1 allows us to reduce $S(\nu z_\tau - z_\tau, \tilde{g}_\Gamma)$ for the tilde relations that were in \mathcal{G}_1 . We may also conclude immediately from Proposition 4.4.3 and the fact that the leading term of \tilde{g}_Γ is never divisible by z_τ^i for any i that $S(\nu z_\tau - z_\tau, \tilde{g}_\Gamma) \rightarrow 0$.

We essentially prove two results in the remainder of this section, although technicalities in the computations make it appear that there are more. First, there is a slight generalization of Corollary 4.4.10 in which we demonstrate that S-polynomials of subset relations for pairs of in-led subsets Γ and Δ can also be expressed in terms of subset relations for $\Gamma \setminus (\Gamma \cap \Delta)$ and $\Delta \setminus (\Gamma \cap \Delta)$. Second, there is a result stating that S-polynomials pairing in-led and out-led subset relations can be expressed in terms of the union and the intersection of the original two subsets. Since the plain, bar, and tilde relations to which we must apply these results differ only with respect to which z_τ^j and z_β^j appear, we will frequently apply Proposition 4.4.7 so that we may compute separately for the boundary edges and for the internal edges.

We state several results in this section in terms of the non-local relations we hope to eventually produce. We write $z_{\Gamma,\beta,\Delta}$ to denote the product of edges z_{β}^i such that z_{τ}^i is outgoing from Γ and z_{β}^i is incoming to Δ . These are the edges that would go from Γ to Δ in the closure of our braid diagram. Similarly, we write $z_{\Gamma,\tau,\Delta}$ to denote the product of z_{τ}^i for strands i with the same property. The non-local relations as originally defined are then

$$n_{\Gamma} = x_{\Gamma,D\setminus\Gamma} z_{\Gamma,\tau,\Delta} - x_{D\setminus\Gamma,\Gamma} z_{D\setminus\Gamma,\beta,\Gamma}.$$

We may reduce these by closure relations $z_{\tau}^i - z_{\beta}^i$ to obtain

$$\bar{n}_{\Gamma} = x_{\Gamma,D\setminus\Gamma} z_{\Gamma,\beta,D\setminus\Gamma} - x_{D\setminus\Gamma,\Gamma} z_{D\setminus\Gamma,\beta,\Gamma},$$

which will have the same term order as \bar{g}_{Γ} because

$$\bar{g}_{\Gamma} = z_{\Gamma,\beta,\Gamma} \bar{n}_{\Gamma}.$$

We write $\bar{n}_{\Gamma}^{\text{out}}$ and $\bar{n}_{\Gamma}^{\text{in}}$ to denote the first and second terms as written above.

Proposition 4.5.4. *Let $\Gamma, \Delta \subset D$. Assume term orders of the S-polynomial input are as written.*

Then

$$\begin{aligned} & S(x_{D\setminus\Gamma,\Gamma} - x_{\Gamma,D\setminus\Gamma}, x_{D\setminus\Delta,\Delta} - x_{\Delta,D\setminus\Delta}) \\ &= x_{\Gamma\cap\Delta,D\setminus(\Gamma\cup\Delta)} \left(x_{\Delta\setminus(\Gamma\cap\Delta)}^{\text{in}} x_{\Gamma\setminus(\Gamma\cap\Delta)}^{\text{out}} - x_{\Gamma\setminus(\Gamma\cap\Delta)}^{\text{in}} x_{\Delta\setminus(\Gamma\cap\Delta)}^{\text{out}} \right), \end{aligned}$$

where the term order of the result is unknown in general.

Proof. The computation here is identical to the computation in the proof of Proposition 4.4.10 with the roles of Γ and its complement reversed (and Δ and its complement reversed). \square

Proposition 4.5.5. *Let $\Gamma, \Delta \subset D$. Assume term orders of the S-polynomial input are as written.*

Then

$$\begin{aligned} & S(x_{D\setminus\Gamma,\Gamma} - x_{\Gamma,D\setminus\Gamma}, x_{\Delta,D\setminus\Delta} - x_{D\setminus\Delta,\Delta}) = \\ & x_{\Gamma\setminus(\Gamma\cap\Delta),\Delta\setminus(\Gamma\cap\Delta)} \left(x_{\Gamma\cup\Delta,D\setminus(\Gamma\cup\Delta)} x_{\Gamma\cap\Delta,D\setminus(\Gamma\cap\Delta)} - x_{D\setminus(\Gamma\cup\Delta),\Gamma\cup\Delta} x_{D\setminus(\Gamma\cap\Delta),\Gamma\cap\Delta} \right), \end{aligned}$$

where the term order of the result is unknown in general.

Proof. The key observation behind this proposition is that the greatest common divisor of leading terms will be the edges that go from Δ to Γ . The S-polynomial removes those edges, which are internal to $\Gamma \cup \Delta$, while combining the incoming edges of Γ with those of Δ and the outgoing edges of Γ with those of Δ .

Specifically, the greatest common divisor of the leading terms is $x_{\Delta \setminus (\Gamma \cap \Delta), \Gamma \setminus (\Gamma \cap \Delta)}$, so the least common multiple is

$$x_{\Delta \setminus (\Gamma \cap \Delta), \Gamma \setminus (\Gamma \cap \Delta)} \cdot x_{D \setminus (\Gamma \cup \Delta), \Gamma \setminus (\Gamma \cap \Delta)} x_{D \setminus \Gamma, \Gamma \cap \Delta} \cdot x_{\Delta \setminus (\Gamma \cap \Delta), D \setminus (\Gamma \cup \Delta)} x_{\Gamma \cap \Delta, D \setminus \Delta}$$

and the S-polynomial calculation is as follows.

$$\begin{aligned} S(x_{D \setminus \Gamma, \Gamma} - x_{\Gamma, D \setminus \Gamma}, x_{\Delta, D \setminus \Delta} - x_{D \setminus \Delta, \Delta}) &= x_{\Delta \setminus (\Gamma \cap \Delta), D \setminus (\Gamma \cup \Delta)} x_{\Gamma \cap \Delta, D \setminus \Delta} \cdot x_{\Gamma, D \setminus \Gamma} \\ &\quad - x_{D \setminus (\Gamma \cup \Delta), \Gamma \setminus (\Gamma \cap \Delta)} x_{D \setminus \Gamma, \Gamma \cap \Delta} \cdot x_{D \setminus \Delta, \Delta} \\ &= x_{\Delta \setminus (\Gamma \cap \Delta), D \setminus (\Gamma \cup \Delta)} x_{\Gamma \cap \Delta, D \setminus (\Gamma \cup \Delta)} x_{\Gamma \cap \Delta, \Gamma \setminus (\Gamma \cap \Delta)} \\ &\quad \cdot x_{\Gamma \setminus (\Gamma \cap \Delta), D \setminus (\Gamma \cup \Delta)} x_{\Gamma \setminus (\Gamma \cap \Delta), \Delta \setminus (\Gamma \cap \Delta)} x_{\Gamma \cap \Delta, D \setminus (\Gamma \cup \Delta)} x_{\Gamma \cap \Delta, \Delta \setminus (\Gamma \cap \Delta)} \\ &\quad - x_{D \setminus (\Gamma \cup \Delta), \Gamma \setminus (\Gamma \cap \Delta)} x_{D \setminus (\Gamma \cup \Delta), \Gamma \cap \Delta} x_{\Delta \setminus (\Gamma \cap \Delta), \Gamma \cap \Delta} \\ &\quad \cdot x_{D \setminus (\Gamma \cup \Delta), \Delta \setminus (\Gamma \cap \Delta)} x_{D \setminus (\Gamma \cup \Delta), \Gamma \cap \Delta} x_{\Gamma \setminus (\Gamma \cap \Delta), \Delta \setminus (\Gamma \cap \Delta)} x_{\Gamma \setminus (\Gamma \cap \Delta), \Gamma \cap \Delta} \\ &= x_{\Gamma \setminus (\Gamma \cap \Delta), \Delta \setminus (\Gamma \cap \Delta)} (x_{\Gamma \cup \Delta, D \setminus (\Gamma \cup \Delta)} x_{\Gamma \cap \Delta, D \setminus (\Gamma \cap \Delta)} \\ &\quad - x_{D \setminus (\Gamma \cup \Delta), \Gamma \cup \Delta} x_{D \setminus (\Gamma \cap \Delta), \Gamma \cap \Delta}) \quad \square \end{aligned}$$

So far, we have established that S-polynomials of the internal edge portions of subset relations can always be written in terms of the internal edge portions of other subset relations (unions, intersections, etc. of the original subsets). The next task is to consider the boundary edge portions of subset relations and to compute separately for the plain, bar, and tilde relations.

Proposition 4.5.6. *Let Γ and Δ be subsets of D .*

1. *If Γ is in-led, then*

$$S(\bar{g}_\Gamma, g_\Delta) \xrightarrow{z_\tau^i - z_\beta^i} x_{\Gamma \setminus (\Gamma \cap \Delta), \Delta \setminus (\Gamma \cap \Delta)} (\bar{g}_{\Gamma \cup \Delta}^{\text{out}} g_{\Gamma \cap \Delta}^{\text{out}} - \bar{g}_{\Gamma \cup \Delta}^{\text{in}} g_{\Gamma \cap \Delta}^{\text{in}}).$$

2. *If Γ is out-led, then*

$$S(\bar{g}_\Gamma, g_\Delta) \xrightarrow{z_\tau^i - z_\beta^i} x_{\Gamma \cap \Delta, D \setminus (\Gamma \cup \Delta)} z_{\beta, \Gamma \cap \Delta} z_{\Gamma \cap \Delta, \tau}^\beta \left(\bar{g}_{\Gamma \setminus (\Gamma \cap \Delta)}^{\text{in}} g_{\Delta \setminus (\Gamma \cap \Delta)}^{\text{out}} - g_{\Delta \setminus (\Gamma \cap \Delta)}^{\text{in}} \bar{g}_{\Gamma \setminus (\Gamma \cap \Delta)}^{\text{out}} \right).$$

3. *If Γ and Δ are both in-led, then*

$$S(\bar{g}_\Gamma, \bar{g}_\Delta) = x_{\Gamma \cap \Delta, D \setminus (\Gamma \cup \Delta)} z_{\beta, \Gamma \cap \Delta} \left(\bar{g}_{\Delta \setminus (\Gamma \cap \Delta)}^{\text{in}} \bar{g}_{\Gamma \setminus (\Gamma \cap \Delta)}^{\text{out}} - \bar{g}_{\Gamma \setminus (\Gamma \cap \Delta)}^{\text{in}} \bar{g}_{\Delta \setminus (\Gamma \cap \Delta)}^{\text{out}} \right).$$

4. *If Γ and Δ are both out-led, then*

$$S(\bar{g}_\Gamma, \bar{g}_\Delta) = x_{D \setminus (\Gamma \cup \Delta), \Gamma \cap \Delta} z_{\Gamma \cap \Delta, \tau}^\beta \left(\bar{g}_{\Delta \setminus (\Gamma \cap \Delta)}^{\text{in}} \bar{g}_{\Gamma \setminus (\Gamma \cap \Delta)}^{\text{out}} - \bar{g}_{\Gamma \setminus (\Gamma \cap \Delta)}^{\text{in}} \bar{g}_{\Delta \setminus (\Gamma \cap \Delta)}^{\text{out}} \right).$$

5. If Γ is in-led and Δ is out-led, then

$$S(\bar{g}_\Gamma, \bar{g}_\Delta) = x_{\Gamma \setminus (\Gamma \cap \Delta), \Delta \setminus (\Gamma \cap \Delta)} z_{\Gamma \setminus (\Gamma \cap \Delta), \beta, \Gamma \cup \Delta} z_{\Delta, \beta, \Delta \setminus (\Gamma \cap \Delta)} (\bar{n}_{\Gamma \cup \Delta}^{\text{out}} \bar{g}_{\Gamma \cap \Delta}^{\text{out}} - \bar{n}_{\Gamma \cup \Delta}^{\text{in}} \bar{g}_{\Gamma \cap \Delta}^{\text{in}}).$$

Term orders of the results are unspecified in all cases.

Proof. Case 1: The computation for the internal edges is taken care of in Proposition 4.5.5, so we proceed with the computation for the boundary edges and then combine them using Proposition 4.4.7. The greatest common divisor of the leading terms is 1.

$$\begin{aligned} S(z_{\beta, \Gamma} - z_{\Gamma, \tau}^\beta, z_{\Delta, \tau} - z_{\beta, \Delta}) &= z_{\Delta, \tau} z_{\Gamma, \tau}^\beta - z_{\beta, \Gamma} z_{\beta, \Delta} \\ &= z_{\Gamma \cup \Delta, \beta, \Gamma \cup \Delta} (z_{\Gamma \cap \Delta, \tau} z_{\Delta \setminus (\Gamma \cap \Delta), \tau, D \setminus (\Gamma \cup \Delta)} z_{\Gamma, \beta, D \setminus (\Gamma \cup \Delta)} \\ &\quad - z_{\beta, \Gamma \cap \Delta} z_{D \setminus (\Gamma \cap \Delta), \beta, \Gamma \cup \Delta}) \end{aligned}$$

We may reduce this result by $z_\tau^j - z_\beta^j$ for the necessary j to convert $z_{\Delta \setminus (\Gamma \cap \Delta), \tau, D \setminus (\Gamma \cup \Delta)}$ to $z_{\Delta \setminus (\Gamma \cap \Delta), \beta, D \setminus (\Gamma \cup \Delta)}$. That is,

$$\begin{aligned} S(z_{\beta, \Gamma} - z_{\Gamma, \tau}^\beta, z_{\Delta, \tau} - z_{\beta, \Delta}) &\xrightarrow{\{z_\tau^j - z_\beta^j\}} \\ & z_{\Gamma \cup \Delta, \beta, \Gamma \cup \Delta} (z_{\Gamma \cap \Delta, \tau} z_{\Gamma \cup \Delta, \beta, D \setminus (\Gamma \cup \Delta)} - z_{\beta, \Gamma \cap \Delta} z_{D \setminus (\Gamma \cap \Delta), \beta, \Gamma \cup \Delta}). \end{aligned}$$

Combining with the result in Proposition 4.5.5 produces

$$\begin{aligned} S(\bar{g}_\Gamma, g_\Delta) &= x_{\Gamma \setminus (\Gamma \cap \Delta), \Delta \setminus (\Gamma \cap \Delta)} z_{\Gamma \cup \Delta, \beta, \Gamma \cup \Delta} \\ &\quad \cdot (x_{\Gamma \cup \Delta, D \setminus (\Gamma \cup \Delta)} z_{\Gamma \cup \Delta, \beta, D \setminus (\Gamma \cup \Delta)} x_{\Gamma \cap \Delta, D \setminus (\Gamma \cap \Delta)} z_{\Gamma \cap \Delta, \tau} \\ &\quad - x_{D \setminus (\Gamma \cup \Delta), \Gamma \cup \Delta} z_{D \setminus (\Gamma \cup \Delta), \beta, \Gamma \cup \Delta} x_{D \setminus (\Gamma \cap \Delta), \Gamma \cap \Delta} z_{\beta, \Gamma \cap \Delta}) \\ &= x_{\Gamma \setminus (\Gamma \cap \Delta), \Delta \setminus (\Gamma \cap \Delta)} (\bar{g}_{\Gamma \cup \Delta}^{\text{out}} g_{\Gamma \cap \Delta}^{\text{out}} - \bar{g}_{\Gamma \cup \Delta}^{\text{in}} g_{\Gamma \cap \Delta}^{\text{in}}). \end{aligned}$$

Case 2: We use the same strategy as above, computing an S-polynomial for the boundary edges first, then combining it using Proposition 4.4.7 with the computation in Proposition 4.4.10 for the internal edges.

The difference in the computation for boundary edges is only that \bar{g}_Γ now has the opposite term order, but the greatest common divisor of leading terms is still 1.

$$S(z_{\Gamma, \tau}^\beta - z_{\beta, \Gamma}, z_{\Delta, \tau} - z_{\beta, \Delta}) = z_{\Delta, \tau} z_{\beta, \Gamma} - z_{\Gamma, \tau}^\beta z_{\beta, \Delta}$$

Combining with the result in Proposition 4.4.10 using the formula in Proposition 4.4.7 produces

$$\begin{aligned} S(\bar{g}_\Gamma, g_\Delta) &= x_{\Gamma \cap \Delta, D \setminus (\Gamma \cup \Delta)} \left(x_{\Gamma \setminus (\Gamma \cap \Delta)}^{\text{in}} z_{\beta, \Gamma} x_{\Delta \setminus (\Gamma \cap \Delta)}^{\text{out}} z_{\Delta, \tau} - x_{\Delta \setminus (\Gamma \cap \Delta)}^{\text{in}} z_{\beta, \Delta} x_{\Gamma \setminus (\Gamma \cap \Delta)}^{\text{out}} z_{\Gamma, \tau}^\beta \right) \\ &= x_{\Gamma \cap \Delta, D \setminus (\Gamma \cup \Delta)} z_{\beta, \Gamma \cap \Delta} (x_{\Gamma \setminus (\Gamma \cap \Delta)}^{\text{in}} z_{\beta, \Gamma \setminus (\Gamma \cap \Delta)} x_{\Delta \setminus (\Gamma \cap \Delta)}^{\text{out}} z_{\Delta \setminus (\Gamma \cap \Delta), \tau} z_{\Gamma \cap \Delta, \tau} \\ &\quad - x_{\Delta \setminus (\Gamma \cap \Delta)}^{\text{in}} z_{\beta, \Delta \setminus (\Gamma \cap \Delta)} x_{\Gamma \setminus (\Gamma \cap \Delta)}^{\text{out}} z_{\Gamma \setminus (\Gamma \cap \Delta), \tau}^\beta z_{\Gamma \cap \Delta, \tau}^\beta) \\ &= x_{\Gamma \cap \Delta, D \setminus (\Gamma \cup \Delta)} z_{\beta, \Gamma \cap \Delta} (\bar{g}_{\Gamma \setminus (\Gamma \cap \Delta)}^{\text{in}} g_{\Delta \setminus (\Gamma \cap \Delta)}^{\text{out}} z_{\Gamma \cap \Delta, \tau} - g_{\Delta \setminus (\Gamma \cap \Delta)}^{\text{in}} \bar{g}_{\Gamma \setminus (\Gamma \cap \Delta)}^{\text{out}} z_{\Gamma \cap \Delta, \tau}^\beta) \end{aligned}$$

with an unknown term order. After reducing by $z_\tau^i - z_\beta^i$ for any divisors of $z_{\Gamma \cap \Delta, \tau}$, we obtain the expression in the statement of the proposition.

Cases 3 and 4: We assume that both Γ and Δ are out-led. The computation if both are in-led is similar except that all term orders are reversed throughout. The computation for the boundary edges goes as follows.

$$\begin{aligned} S(z_{\Gamma, \tau}^\beta - z_{\beta, \Gamma}, z_{\Delta, \tau}^\beta - z_{\beta, \Delta}) &= \frac{z_{\Gamma, \tau}^\beta z_{\Delta, \tau}^\beta}{z_{\Gamma \cap \Delta, \tau}^\beta} \frac{1}{z_{\Gamma, \tau}^\beta} (-z_{\beta, \Gamma}) - \frac{z_{\Gamma, \tau}^\beta z_{\Delta, \tau}^\beta}{z_{\Gamma \cap \Delta, \tau}^\beta} \frac{1}{z_{\Delta, \tau}^\beta} (-z_{\beta, \Delta}) \\ &= -z_{\Delta \setminus (\Gamma \cap \Delta), \tau}^\beta z_{\beta, \Gamma} + z_{\Gamma \setminus (\Gamma \cap \Delta), \tau}^\beta z_{\beta, \Delta} \\ &= -z_{\beta, \Gamma \cap \Delta} \left(z_{\Delta \setminus (\Gamma \cap \Delta), \tau}^\beta z_{\beta, \Gamma \setminus (\Gamma \cap \Delta)} - z_{\Gamma \setminus (\Gamma \cap \Delta), \tau}^\beta z_{\beta, \Delta \setminus (\Gamma \cap \Delta)} \right) \end{aligned}$$

Combining with the result from Proposition 4.4.10, we have the following.

$$\begin{aligned} S(\bar{g}_\Gamma, \bar{g}_\Delta) &= x_{\Gamma \cap \Delta, D \setminus (\Gamma \cup \Delta)} z_{\beta, \Gamma \cap \Delta} (x_{\Delta \setminus (\Gamma \cap \Delta)}^{\text{in}} z_{\beta, \Delta \setminus (\Gamma \cap \Delta)} x_{\Gamma \setminus (\Gamma \cap \Delta)}^{\text{out}} z_{\Gamma \setminus (\Gamma \cap \Delta), \tau}^\beta \\ &\quad - x_{\Gamma \setminus (\Gamma \cap \Delta)}^{\text{in}} z_{\beta, \Gamma \setminus (\Gamma \cap \Delta)} x_{\Delta \setminus (\Gamma \cap \Delta)}^{\text{out}} z_{\Delta \setminus (\Gamma \cap \Delta), \tau}^\beta) \\ &= x_{\Gamma \cap \Delta, D \setminus (\Gamma \cup \Delta)} z_{\beta, \Gamma \cap \Delta} \left(\bar{g}_{\Delta \setminus (\Gamma \cap \Delta)}^{\text{in}} \bar{g}_{\Gamma \setminus (\Gamma \cap \Delta)}^{\text{out}} - \bar{g}_{\Gamma \setminus (\Gamma \cap \Delta)}^{\text{in}} \bar{g}_{\Delta \setminus (\Gamma \cap \Delta)}^{\text{out}} \right) \end{aligned}$$

Case 5: The S-polynomial of boundary edges only is as follows.

$$\begin{aligned} S(z_{\beta, \Gamma} - z_{\Gamma, \tau}^\beta, z_{\Delta, \tau}^\beta - z_{\beta, \Delta}) &= \frac{z_{\beta, \Gamma} z_{\Delta, \tau}^\beta}{z_{\Delta, \beta, \Gamma}} \frac{1}{z_{\beta, \Gamma}} \left(-z_{\Gamma, \tau}^\beta \right) - \frac{z_{\beta, \Gamma} z_{\Delta, \tau}^\beta}{z_{\Delta, \beta, \Gamma}} \frac{1}{z_{\Delta, \tau}^\beta} (-z_{\beta, \Delta}) \\ &= -z_{\Delta, \beta, D \setminus \Gamma} z_{\Gamma, \tau}^\beta + z_{D \setminus \Delta, \beta, \Gamma} z_{\beta, \Delta} \end{aligned}$$

Combining this with the result of Proposition 4.5.5 produces the following, in which the term order is unknown.

$$\begin{aligned} S(\bar{g}_\Gamma, \bar{g}_\Delta) &= x_{\Gamma \setminus (\Gamma \cap \Delta), \Delta \setminus (\Gamma \cap \Delta)} \\ &\quad \cdot (x_{\Gamma \cup \Delta, D \setminus (\Gamma \cup \Delta)} x_{\Gamma \cap \Delta, D \setminus (\Gamma \cap \Delta)} z_{\Delta, \beta, D \setminus \Gamma} z_{\Gamma, \tau}^\beta - x_{D \setminus (\Gamma \cup \Delta), \Gamma \cup \Delta} x_{D \setminus (\Gamma \cap \Delta), \Gamma \cap \Delta} z_{D \setminus \Delta, \beta, \Gamma} z_{\beta, \Delta}) \\ &= x_{\Gamma \setminus (\Gamma \cap \Delta), \Delta \setminus (\Gamma \cap \Delta)} z_{\Gamma \setminus (\Gamma \cap \Delta), \beta, \Gamma \cup \Delta} z_{\Gamma \cap \Delta, \beta, \Delta} z_{\Delta \setminus (\Gamma \cap \Delta), \beta, \Delta \setminus (\Gamma \cap \Delta)} \\ &\quad \cdot (\bar{n}_{\Gamma \cup \Delta}^{\text{out}} \bar{n}_{\Gamma \cap \Delta}^{\text{out}} - \bar{n}_{\Gamma \cup \Delta}^{\text{in}} \bar{n}_{\Gamma \cap \Delta}^{\text{in}}) \end{aligned}$$

Rearranging slightly, we may put $z_{\Gamma \cap \Delta, \beta, \Gamma \cap \Delta}$ back into the factors of $\bar{n}_{\Gamma \cap \Delta}$ and state the result in terms of $\bar{g}_{\Gamma \cap \Delta}$ instead. \square

The term orders are uncertain in all of the results in Proposition 4.5.6. However, Proposition 4.2.5 says that the four expressions we have obtained are each reducible by their constituent parts. For

cases 1–4, this means that the S-polynomials are reducible by relations already in our working basis:

$$\begin{aligned} S(\bar{g}_\Gamma, g_\Delta) &\xrightarrow{z_\tau^i - z_\beta^i, g_{\Gamma \cap \Delta}, \bar{g}_{\Gamma \cup \Delta}} 0 \text{ if } \Gamma \text{ in-led;} \\ S(\bar{g}_\Gamma, g_\Delta) &\xrightarrow{z_\tau^i - z_\beta^i, g_{\Delta \setminus (\Gamma \cap \Delta)}, \bar{g}_{\Gamma \setminus (\Gamma \cap \Delta)}} 0 \text{ if } \Gamma \text{ out-led;} \text{ and} \\ S(\bar{g}_\Gamma, \bar{g}_\Delta) &\xrightarrow{\bar{g}_{\Gamma \setminus (\Gamma \cap \Delta)}, \bar{g}_{\Delta \setminus (\Gamma \cap \Delta)}} 0 \text{ if } \Gamma \text{ and } \Delta \text{ are both in-led or both out-led.} \end{aligned}$$

We cannot yet reduce the S-polynomial in case 5, so instead we carry it on to the next round.

4.5.3 S-polynomials involving tilde relations

Having checked all S-polynomials among plain and bar relations, we now move on to tilde relations. Like $\nu z_\tau - z_\tau$ and $\nu z_\beta - z_\beta$, the tilde relations are differences of monomials with ν dividing only one of the two terms. We establish here a few properties of the tilde relations similar to those we proved for $\nu z_\tau - z_\tau$ and $\nu z_\beta - z_\beta$ in Propositions 4.4.3 and 4.5.1.

Proposition 4.5.7. *Let $f, f', g, g' \in \mathbb{Q}[\underline{x}]$ be monomials. Then*

$$\begin{aligned} S(\nu f + f', \nu g + g') &= S(f + f', g + g'), \\ S(\nu f + f', \nu g + \nu g') &= S(\nu f + f', g + g'), \end{aligned}$$

and if the former reduces with either term order, then so does the latter.

If $\gcd(f, g) = 1$, then

$$S(\nu f + f', \nu g + \nu g') \xrightarrow{\nu f + f', \nu g + \nu g'} 0.$$

Proof. Both equalities follow from routine calculations. Let $d = \gcd(f, g)$.

$$\begin{aligned} S(\nu f + f', \nu g + g') &= \frac{\nu f g}{d} \frac{1}{\nu f} f' - \frac{\nu f g}{d} \frac{1}{\nu g} g' \\ &= \frac{g}{d} f' - \frac{f}{d} g' \\ &= S(f + f', g + g') \end{aligned}$$

The term order above is unknown in general.

$$\begin{aligned} S(\nu f + f', \nu g + \nu g') &= \frac{\nu f g}{d} \frac{1}{\nu f} f' - \frac{\nu f g}{d} \frac{1}{\nu g} \nu g' \\ &= -\nu \frac{f}{d} g' + \frac{g}{d} f' \\ &= S(\nu f + f', g + g') \end{aligned}$$

The results of these two calculations differ only by the presence of ν on one term, and possibly term order. If the former S-polynomial reduces regardless of term order, then the latter S-polynomial

reduces by the same polynomials, multiplied by ν . If $d = 1$, then the last expression is reducible by its constituent parts. \square

As an immediate corollary, we have that $S(\tilde{g}_\Gamma, \nu z_\tau^i - \nu z_\beta^i)$ reduces to zero in the current working basis.

Proposition 4.5.8. *Let $\Gamma \subset D$ be out-led and $z_{\Gamma,\tau} \neq 1$ or Γ be in-led and $z_{\Gamma,\tau} \neq 1$ and $z_{\beta,\Gamma} \neq 1$. Let $f \in \mathbb{Q}[\underline{x}']$. Then*

$$S(\tilde{g}_\Gamma, z_\tau f) = z_\tau S(\tilde{g}_\Gamma, f).$$

Proof. Let $f = \text{LT}(f) + f'$. The result follows by direct computations with each possible term order of \tilde{g}_Γ . We show explicitly the case in which Γ is out-led. Let $d = \gcd(\text{LT}(f), x_{D \setminus \Gamma, \Gamma} z_{\beta, \Gamma} z_{D \setminus \Gamma, \tau}^\beta)$.

$$\begin{aligned} S(\nu x_{D \setminus \Gamma, \Gamma} z_{\beta, \Gamma} z_{D \setminus \Gamma, \tau}^\beta - x_{\Gamma, D \setminus \Gamma} z_\tau, z_\tau f) &= \frac{\nu x_{D \setminus \Gamma, \Gamma} z_{\beta, \Gamma} z_{D \setminus \Gamma, \tau}^\beta \text{LT}(f)}{d \nu x_{D \setminus \Gamma, \Gamma} z_{\beta, \Gamma} z_{D \setminus \Gamma, \tau}^\beta} (-x_{\Gamma, D \setminus \Gamma} z_\tau) \\ &\quad - \frac{\nu x_{D \setminus \Gamma, \Gamma} z_{\beta, \Gamma} z_{D \setminus \Gamma, \tau}^\beta \text{LT}(f)}{d z_\tau \text{LT}(f)} (z_\tau f') \\ &= \nu z_\tau f' x_{D \setminus \Gamma, \Gamma} z_{\beta, \Gamma} z_{D \setminus \Gamma, \tau}^\beta - z_\tau^2 \frac{\text{LT}(f)}{d} x_{\Gamma, D \setminus \Gamma} \\ \text{reduce} \quad &- f' x_{D \setminus \Gamma, \Gamma} z_{\beta, \Gamma} z_{D \setminus \Gamma, \tau}^\beta (\nu z_\tau - z_\tau) \\ \text{LT unknown} \quad &= z_\tau \left(f' x_{D \setminus \Gamma, \Gamma} z_{\beta, \Gamma} z_{D \setminus \Gamma, \tau}^\beta - z_\tau \frac{\text{LT}(f)}{d} x_{\Gamma, D \setminus \Gamma} \right) \\ &= z_\tau S(\tilde{g}_\Gamma, f) \quad \square \end{aligned}$$

We are now equipped to analyze the interaction of the tilde relations with the other subset relations.

Proposition 4.5.9. *Let Γ and Δ be subsets of D .*

1. *If Γ is out-led and $z_{\Gamma,\tau} \neq 1$, then*

$$S(\tilde{g}_\Gamma, g_\Delta) = x_{\Gamma \setminus (\Gamma \cap \Delta), \Delta \setminus (\Gamma \cap \Delta)} \left(\nu g_{\Gamma \cup \Delta}^{\text{in}} g_{\Gamma \cap \Delta}^{\text{in}} z_{D \setminus \Gamma, \tau}^\beta - g_{\Gamma \cup \Delta}^{\text{out}} g_{\Gamma \cap \Delta}^{\text{out}} z_{D \setminus \Gamma, \tau} \right).$$

2. *If Γ is in-led, $z_{\Gamma,\tau} \neq 1$, and $z_{\beta,\Gamma} \neq 1$, then*

$$S(\tilde{g}_\Gamma, g_\Delta) = x_{\Gamma \cap \Delta, D \setminus (\Gamma \cup \Delta)} \left(\nu g_{\Delta \setminus (\Gamma \cap \Delta)}^{\text{in}} \tilde{g}_{\Gamma \setminus (\Gamma \cap \Delta)}^{\text{out}} z_{\Gamma \cap \Delta, \tau}^\beta - \tilde{g}_{\Gamma \setminus (\Gamma \cap \Delta)}^{\text{in}} g_{\Delta \setminus (\Gamma \cap \Delta)}^{\text{out}} z_{\Gamma \cap \Delta, \tau} \right).$$

3. *If Γ and Δ are both in-led with $z_{\Gamma,\tau} \neq 1$, $z_{\beta,\Gamma} \neq 1$, $z_{\Delta,\tau} \neq 1$, and $z_{\beta,\Delta} \neq 1$, then*

$$S(\tilde{g}_\Gamma, \tilde{g}_\Delta) = z_\tau x_{\Gamma \cap \Delta, D \setminus (\Gamma \cup \Delta)} \left(\bar{n}_{\Delta \setminus (\Gamma \cap \Delta)}^{\text{in}} \bar{n}_{\Gamma \setminus (\Gamma \cap \Delta)}^{\text{out}} - \bar{n}_{\Gamma \setminus (\Gamma \cap \Delta)}^{\text{in}} \bar{n}_{\Delta \setminus (\Gamma \cap \Delta)}^{\text{out}} \right).$$

4. If Γ and Δ are both out-led with $z_{\Gamma,\tau} \neq 1$ and $z_{\Delta,\tau} \neq 1$, then

$$S(\tilde{g}_\Gamma, \tilde{g}_\Delta) = z_\tau x_{D \setminus (\Gamma \cup \Delta), \Gamma \cap \Delta} \left(\bar{n}_{\Delta \setminus (\Gamma \cap \Delta)}^{\text{in}} \bar{n}_{\Gamma \setminus (\Gamma \cap \Delta)}^{\text{out}} - \bar{n}_{\Gamma \setminus (\Gamma \cap \Delta)}^{\text{in}} \bar{n}_{\Delta \setminus (\Gamma \cap \Delta)}^{\text{out}} \right).$$

5. If Γ is in-led, $z_{\Gamma,\tau} \neq 1$, and $z_{\beta,\Gamma} \neq 1$, and Δ is out-led, $z_{\Delta,\tau} \neq 1$, then

$$S(\tilde{g}_\Gamma, \tilde{g}_\Delta) = z_\tau x_{\Gamma \setminus (\Gamma \cap \Delta), \Delta \setminus (\Gamma \cap \Delta)} \left(\bar{n}_{\Gamma \cup \Delta}^{\text{out}} \bar{n}_{\Gamma \cap \Delta}^{\text{out}} - \bar{n}_{\Gamma \cup \Delta}^{\text{in}} \bar{n}_{\Gamma \cap \Delta}^{\text{in}} \right).$$

6. If Γ is out-led and Δ is in-led and $z_{\Gamma,\tau} \neq 1$, $z_{\Delta,\tau} \neq 1$, then

$$\begin{aligned} S(\tilde{g}_\Gamma, \bar{g}_\Delta) &= x_{\Gamma \cap \Delta, D \setminus (\Gamma \cup \Delta)} (\nu \bar{g}_{\Delta \setminus (\Gamma \cap \Delta)}^{\text{out}} g_{\Gamma \setminus (\Gamma \cap \Delta)}^{\text{in}} z_{\Gamma \cap \Delta, \tau}^{\beta} z_{D \setminus \Gamma, \beta, \Gamma \cap \Delta} z_{D \setminus \Gamma, \beta, D \setminus \Delta} \\ &\quad - x_{\Delta \setminus (\Gamma \cap \Delta)}^{\text{in}} x_{\Gamma \setminus (\Gamma \cap \Delta)}^{\text{out}} z_{\Gamma, \beta, \Delta \setminus (\Gamma \cap \Delta)} z_\tau). \end{aligned}$$

7. If Γ is in-led and Δ is out-led and $z_{\Gamma,\tau} \neq 1$, $z_{\beta,\Gamma} \neq 1$, $z_{\Delta,\tau} \neq 1$, then

$$\begin{aligned} S(\tilde{g}_\Gamma, \bar{g}_\Delta) &= x_{D \setminus (\Gamma \cup \Delta), \Gamma \cap \Delta} (\nu \bar{g}_{\Gamma \setminus (\Gamma \cap \Delta)}^{\text{out}} g_{\Delta \setminus (\Gamma \cap \Delta)}^{\text{in}} z_{\beta, \Gamma \cap \Delta} z_{D \setminus \Delta, \beta, D \setminus \Gamma} z_{\Gamma \cap \Delta, \beta, D \setminus \Gamma} \\ &\quad - x_{\Delta \setminus (\Gamma \cap \Delta)}^{\text{out}} x_{\Gamma \setminus (\Gamma \cap \Delta)}^{\text{in}} z_{\Delta \setminus (\Gamma \cap \Delta), \beta, \Gamma} z_\tau). \end{aligned}$$

8. If Γ and Δ are both out-led and $z_{\Gamma,\tau} \neq 1$, $z_{\Delta,\tau} \neq 1$, then

$$\begin{aligned} S(\tilde{g}_\Gamma, \bar{g}_\Delta) &= x_{\Gamma \setminus (\Gamma \cap \Delta), \Delta \setminus (\Gamma \cap \Delta)} \\ &\quad \cdot (\nu n_{\Gamma \cup \Delta}^{\text{in}} g_{\Gamma \cap \Delta}^{\text{in}} z_{\Gamma \cap \Delta, \beta, \Delta \setminus (\Gamma \cap \Delta)} z_{\Gamma \setminus (\Gamma \cap \Delta), \beta, \Gamma} z_{\Delta \setminus (\Gamma \cap \Delta), \beta, \Gamma} z_{D \setminus (\Gamma \cup \Delta), \tau}^{\beta} \\ &\quad - x_{\Gamma \cup \Delta}^{\text{out}} x_{\Gamma \cap \Delta}^{\text{out}} z_{\Gamma \cap \Delta, \beta, D \setminus \Gamma} z_\tau). \end{aligned}$$

9. If Γ and Δ are both in-led and $z_{\Gamma,\tau} \neq 1$, $z_{\beta,\Gamma} \neq 1$, and $z_{\Delta,\tau} \neq 1$, then

$$\begin{aligned} S(\tilde{g}_\Gamma, \bar{g}_\Delta) &= x_{\Delta \setminus (\Gamma \cap \Delta), \Gamma \setminus (\Gamma \cap \Delta)} \\ &\quad \cdot (\nu n_{\Gamma \cup \Delta}^{\text{out}} n_{\Gamma \cap \Delta}^{\text{out}} z_{\beta, D \setminus (\Gamma \cup \Delta)} z_{\Gamma \setminus (\Gamma \cap \Delta), \beta, \Gamma \setminus (\Gamma \cap \Delta)} z_{\Gamma \setminus (\Gamma \cap \Delta), \beta, \Delta \setminus (\Gamma \cap \Delta)} z_{\Delta, \beta, \Gamma \cap \Delta} \\ &\quad - x_{\Gamma \cup \Delta}^{\text{in}} x_{\Gamma \cap \Delta}^{\text{in}} z_{D \setminus \Gamma, \beta, \Gamma \cap \Delta} z_\tau). \end{aligned}$$

Term orders in cases 3–5 are undetermined; all other term orders are determined by ν .

Proof. Each of these results is a straightforward computation.

Case 1: The leading term of g_Δ is necessarily a product of outgoing edges, so this case is similar to Proposition 4.5.5. We compute the S-polynomial explicitly for the boundary edges, then use Proposition 4.4.7 to combine with the calculation for internal edges in Proposition 4.5.5.

The boundary edges in the leading term of \tilde{g}_Γ are all divisors of z_β , while those in the leading term of g_Δ are divisors of z_τ . Therefore, the greatest common divisor of the leading terms is 1, and

the S-polynomial is simply the following.

$$\begin{aligned} S(z_{\beta,\Gamma}z_{D\setminus\Gamma,\tau}^\beta - z_\tau, z_{\Delta,\tau} - z_{\beta,\Delta}) &= z_{\Delta,\tau}z_\tau - z_{\beta,\Gamma}z_{D\setminus\Gamma,\tau}^\beta z_{\beta,\Delta} \\ &= z_{\Delta,\tau}z_\tau - z_{\beta,\Gamma\cup\Delta}z_{\beta,\Gamma\cap\Delta}z_{D\setminus\Gamma,\tau}^\beta \end{aligned}$$

Combining with the S-polynomial of internal edges and inserting ν in the appropriate term yields the following.

$$\begin{aligned} S(\tilde{g}_\Gamma, g_\Delta) &= x_{\Gamma\setminus(\Gamma\cap\Delta),\Delta\setminus(\Gamma\cap\Delta)}(\nu x_{D\setminus(\Gamma\cup\Delta),\Gamma\cup\Delta}x_{D\setminus(\Gamma\cap\Delta),\Gamma\cap\Delta}z_{\beta,\Gamma\cup\Delta}z_{\beta,\Gamma\cap\Delta}z_{D\setminus\Gamma,\tau}^\beta \\ &\quad - x_{\Gamma\cup\Delta,D\setminus(\Gamma\cup\Delta)}x_{\Gamma\cap\Delta,D\setminus(\Gamma\cap\Delta)}z_{\Delta,\tau}z_\tau) \\ &= x_{\Gamma\setminus(\Gamma\cap\Delta),\Delta\setminus(\Gamma\cap\Delta)}\left(\nu g_{\Gamma\cup\Delta}^{\text{in}}g_{\Gamma\cap\Delta}^{\text{in}}z_{D\setminus\Gamma,\tau}^\beta - g_{\Gamma\cup\Delta}^{\text{out}}g_{\Gamma\cap\Delta}^{\text{out}}z_{D\setminus\Gamma,\tau}\right) \end{aligned}$$

Case 2: The leading terms of \tilde{g}_Γ and g_Δ are both products of outgoing edges, so the appropriate internal edge calculation for this case comes from Proposition 4.4.10. The boundary edges that appear in the leading term of \tilde{g}_Γ are all divisors of z_β , while those that appear in the leading term of g_Δ are all divisors of z_τ , so the greatest common divisor of leading terms below is 1. Therefore,

$$S(z_{\Gamma,\tau}^\beta z_{\beta,D\setminus\Gamma} - z_\tau, z_{\Delta,\tau} - z_{\beta,\Delta}) = z_{\Delta,\tau}z_\tau - z_{\Gamma,\tau}^\beta z_{\beta,D\setminus\Gamma} z_{\beta,\Delta}.$$

Combining with the result for the internal edges and placing ν in the appropriate term, we have the following.

$$\begin{aligned} S(\tilde{g}_\Gamma, g_\Delta) &= x_{\Gamma\cap\Delta,D\setminus(\Gamma\cup\Delta)}(\nu x_{\Delta\setminus(\Gamma\cap\Delta)}^{\text{in}}x_{\Gamma\setminus(\Gamma\cap\Delta)}^{\text{out}}z_{\Gamma,\tau}^\beta z_{\beta,D\setminus\Gamma} z_{\beta,\Delta} \\ &\quad - x_{\Gamma\setminus(\Gamma\cap\Delta)}^{\text{in}}x_{\Delta\setminus(\Gamma\cap\Delta)}^{\text{out}}z_{\Delta,\tau}z_\tau) \\ &= x_{\Gamma\cap\Delta,D\setminus(\Gamma\cup\Delta)}\left(\nu g_{\Delta\setminus(\Gamma\cap\Delta)}^{\text{in}}\tilde{g}_{\Gamma\setminus(\Gamma\cap\Delta)}^{\text{out}}z_{\Gamma\cap\Delta,\tau}^\beta - \tilde{g}_{\Gamma\setminus(\Gamma\cap\Delta)}^{\text{in}}g_{\Delta\setminus(\Gamma\cap\Delta)}^{\text{out}}z_{\Gamma\cap\Delta,\tau}\right) \end{aligned}$$

Cases 3 and 4: Assume that Γ and Δ are both out-led. The in-led case is very similar. Then the S-polynomial of the internal edges is the same computation as that in Proposition 4.4.10. Following Proposition 4.4.7, we compute for the boundary edges separately, then recombine with internal edges. First, we need the greatest common divisor of $z_{\beta,\Gamma}z_{D\setminus\Gamma,\tau}^\beta$ and $z_{\beta,\Delta}z_{D\setminus\Delta,\tau}^\beta$. Rewrite these as

$$\begin{aligned} z_{\beta,\Gamma}z_{D\setminus\Gamma,\tau}^\beta &= z_{\beta,\Gamma\cap\Delta}z_{\beta,\Gamma\setminus(\Gamma\cap\Delta)}z_{\Delta\setminus(\Gamma\cap\Delta),\tau}^\beta z_{D\setminus(\Gamma\cup\Delta),\tau}^\beta \text{ and} \\ z_{\beta,\Delta}z_{D\setminus\Delta,\tau}^\beta &= z_{\beta,\Gamma\cap\Delta}z_{\beta,\Delta\setminus(\Gamma\cap\Delta)}z_{\Gamma\setminus(\Gamma\cap\Delta),\tau}^\beta z_{D\setminus(\Gamma\cup\Delta),\tau}^\beta \end{aligned}$$

to see that

$$\gcd(z_{\beta,\Gamma}z_{D\setminus\Gamma,\tau}^\beta, z_{\beta,\Delta}z_{D\setminus\Delta,\tau}^\beta) = z_{\beta,\Gamma\cap\Delta}z_{D\setminus(\Gamma\cup\Delta),\tau}^\beta z_{\Gamma\setminus(\Gamma\cap\Delta),\beta,\Gamma\setminus(\Gamma\cap\Delta)}z_{\Delta\setminus(\Gamma\cap\Delta),\beta,\Delta\setminus(\Gamma\cap\Delta)}$$

Therefore, the S-polynomial calculation for the boundary edges is as follows.

$$\begin{aligned}
 & S(z_{\beta,\Gamma} z_{D\setminus\Gamma,\tau}^\beta - z_\tau, z_{\beta,\Delta} z_{D\setminus\Delta,\tau}^\beta - z_\tau) \\
 &= \frac{z_{\beta,\Delta} z_{D\setminus\Delta,\tau}^\beta}{z_{\beta,\Gamma\cap\Delta} z_{D\setminus(\Gamma\cup\Delta),\tau}^\beta z_{\Gamma\setminus(\Gamma\cap\Delta),\beta} z_{\Gamma\setminus(\Gamma\cap\Delta)} z_{\Delta\setminus(\Gamma\cap\Delta),\beta} z_{\Delta\setminus(\Gamma\cap\Delta)}}{z_{\beta,\Gamma} z_{D\setminus\Gamma,\tau}^\beta} (-z_\tau) \\
 &- \frac{z_{\beta,\Gamma} z_{D\setminus\Gamma,\tau}^\beta}{z_{\beta,\Gamma\cap\Delta} z_{D\setminus(\Gamma\cup\Delta),\tau}^\beta z_{\Gamma\setminus(\Gamma\cap\Delta),\beta} z_{\Gamma\setminus(\Gamma\cap\Delta)} z_{\Delta\setminus(\Gamma\cap\Delta),\beta} z_{\Delta\setminus(\Gamma\cap\Delta)}}{z_{\beta,\Gamma} z_{D\setminus\Gamma,\tau}^\beta} (-z_\tau) \\
 &= -z_\tau (z_{D\setminus\Delta,\beta} z_{\Delta\setminus(\Gamma\cap\Delta)} z_{\Gamma\cap\Delta,\beta} z_{\Delta\setminus(\Gamma\cap\Delta)} z_{\Gamma\setminus(\Gamma\cap\Delta),\beta} z_{D\setminus\Gamma\setminus(\Gamma\cap\Delta),\beta} z_{\Gamma\cap\Delta} \\
 &\quad - z_{D\setminus\Gamma,\beta} z_{\Gamma\setminus(\Gamma\cap\Delta)} z_{\Gamma\cap\Delta,\beta} z_{\Gamma\setminus(\Gamma\cap\Delta)} z_{\Delta\setminus(\Gamma\cap\Delta),\beta} z_{D\setminus\Delta} z_{\Delta\setminus(\Gamma\cap\Delta),\beta} z_{\Gamma\cap\Delta})
 \end{aligned}$$

Putting this together with the result of the S-polynomial of internal edges calculated in Proposition 4.4.10 (and omitting some simplifying steps) produces

$$S(\tilde{g}_\Gamma, \tilde{g}_\Delta) = z_\tau x_{\Gamma\cap\Delta, D\setminus(\Gamma\cup\Delta)} \left(\bar{n}_{\Delta\setminus(\Gamma\cap\Delta)}^{\text{in}} \bar{n}_{\Gamma\setminus(\Gamma\cap\Delta)}^{\text{out}} - \bar{n}_{\Gamma\setminus(\Gamma\cap\Delta)}^{\text{in}} \bar{n}_{\Delta\setminus(\Gamma\cap\Delta)}^{\text{out}} \right),$$

where the term order is unknown.

Case 5: Following Proposition 4.4.7, we compute the S-polynomial for boundary edges separately as follows. The leading terms are now

$$\begin{aligned}
 & z_{\Gamma,\tau}^\beta z_{\beta,D\setminus\Gamma} = z_{\Gamma,\beta,\Delta} z_{\Gamma,\beta,D\setminus\Delta} z_{D\setminus\Delta,\beta,D\setminus\Gamma} z_{\Delta,\beta,D\setminus\Gamma} \text{ and} \\
 & z_{\beta,\Delta} z_{D\setminus\Delta,\tau}^\beta = z_{\Gamma,\beta,\Delta} z_{D\setminus\Gamma,\beta,\Delta} z_{D\setminus\Delta,\beta,D\setminus\Gamma} z_{D\setminus\Delta,\beta,\Gamma}
 \end{aligned}$$

Their greatest common divisor is

$$\gcd(z_{\Gamma,\tau}^\beta z_{\beta,D\setminus\Gamma}, z_{\beta,\Delta} z_{D\setminus\Delta,\tau}^\beta) = z_{\Gamma,\beta,\Delta} z_{D\setminus\Delta,\beta,D\setminus\Gamma} z_{\Gamma\setminus(\Gamma\cap\Delta),\beta} z_{\Gamma\setminus(\Gamma\cap\Delta)} z_{\Delta\setminus(\Gamma\cap\Delta),\beta} z_{\Delta\setminus(\Gamma\cap\Delta)}$$

Therefore the S-polynomial of boundary edges is as follows.

$$\begin{aligned}
 & S(z_{\Gamma,\tau}^\beta z_{\beta,D\setminus\Gamma} - z_\tau, z_{\beta,\Delta} z_{D\setminus\Delta,\tau}^\beta - z_\tau) \\
 &= -z_\tau \left(\frac{z_{\beta,\Delta} z_{D\setminus\Delta,\tau}^\beta}{z_{\Gamma,\beta,\Delta} z_{D\setminus\Delta,\beta,D\setminus\Gamma} z_{\Gamma\setminus(\Gamma\cap\Delta),\beta} z_{\Gamma\setminus(\Gamma\cap\Delta)} z_{\Delta\setminus(\Gamma\cap\Delta),\beta} z_{\Delta\setminus(\Gamma\cap\Delta)}}{z_{\Gamma,\tau}^\beta z_{\beta,D\setminus\Gamma}} \right) \\
 &= -z_\tau (z_{D\setminus(\Gamma\cup\Delta),\beta} z_{\Gamma\cup\Delta} z_{D\setminus(\Gamma\cap\Delta),\beta} z_{\Gamma\cap\Delta} - z_{\Gamma\cup\Delta,\beta} z_{D\setminus(\Gamma\cup\Delta)} z_{\Gamma\cap\Delta,\beta} z_{D\setminus(\Gamma\cap\Delta)})
 \end{aligned}$$

Putting this together with the result for the internal edges in Proposition 4.5.5 produces

$$S(\tilde{g}_\Gamma, \tilde{g}_\Delta) = z_\tau x_{\Gamma\setminus(\Gamma\cap\Delta), \Delta\setminus(\Gamma\cap\Delta)} (\bar{n}_{\Gamma\cup\Delta}^{\text{out}} \bar{n}_{\Gamma\cap\Delta}^{\text{out}} - \bar{n}_{\Gamma\cup\Delta}^{\text{in}} \bar{n}_{\Gamma\cap\Delta}^{\text{in}}),$$

where term order is unknown.

Case 6: The computation for the boundary edges is as follows. The greatest common divisor of leading terms is $z_{\beta, \Gamma \cap \Delta} z_{D \setminus \Gamma, \beta, \Delta \setminus (\Gamma \cap \Delta)}$.

$$S(z_{\beta, \Gamma} z_{D \setminus \Gamma, \tau}^\beta - z_\tau, z_{\beta, \Delta} - z_{\Delta, \tau}^\beta) = z_{\Gamma, \beta, \Delta \setminus (\Gamma \cap \Delta)} z_\tau - z_{\beta, \Gamma \setminus (\Gamma \cap \Delta)} z_{D \setminus \Gamma, \beta, \Gamma \cap \Delta} z_{D \setminus \Gamma, \beta, D \setminus \Delta} z_{\Delta, \tau}^\beta$$

Since Γ is out-led and Δ is in-led, we use the computation for internal edges in Proposition 4.5.4.

$$\begin{aligned} S(\tilde{g}_\Gamma, \bar{g}_\Delta) &= x_{\Gamma \cap \Delta, D \setminus (\Gamma \cup \Delta)} (\nu x_{\Gamma \setminus (\Gamma \cap \Delta)}^{\text{in}} x_{\Delta \setminus (\Gamma \cap \Delta)}^{\text{out}} z_{\beta, \Gamma \setminus (\Gamma \cap \Delta)} z_{D \setminus \Gamma, \beta, \Gamma \cap \Delta} z_{D \setminus \Gamma, \beta, D \setminus \Delta} z_{\Delta, \tau}^\beta \\ &\quad - x_{\Delta \setminus (\Gamma \cap \Delta)}^{\text{in}} x_{\Gamma \setminus (\Gamma \cap \Delta)}^{\text{out}} z_{\Gamma, \beta, \Delta \setminus (\Gamma \cap \Delta)} z_\tau) \\ &= x_{\Gamma \cap \Delta, D \setminus (\Gamma \cup \Delta)} (\nu \bar{g}_{\Delta \setminus (\Gamma \cap \Delta)}^{\text{out}} g_{\Gamma \setminus (\Gamma \cap \Delta)}^{\text{in}} z_{\Gamma \cap \Delta, \tau}^\beta z_{D \setminus \Gamma, \beta, \Gamma \cap \Delta} z_{D \setminus \Gamma, \beta, D \setminus \Delta} \\ &\quad - x_{\Delta \setminus (\Gamma \cap \Delta)}^{\text{in}} x_{\Gamma \setminus (\Gamma \cap \Delta)}^{\text{out}} z_{\Gamma, \beta, \Delta \setminus (\Gamma \cap \Delta)} z_\tau) \end{aligned}$$

Case 7: The computation for the boundary edges is as follows. The greatest common divisor of leading terms is $z_{\Gamma \cap \Delta, \tau}^\beta z_{\Delta \setminus (\Gamma \cap \Delta), \beta, D \setminus \Gamma}$.

$$S(z_{\beta, D \setminus \Gamma} z_{\Gamma, \tau}^\beta - z_\tau, z_{\Delta, \tau}^\beta - z_{\beta, \Delta}) = z_{\Delta \setminus (\Gamma \cap \Delta), \beta, \Gamma} z_\tau - z_{\Gamma \setminus (\Gamma \cap \Delta), \tau}^\beta z_{D \setminus \Delta, \beta, D \setminus \Gamma} z_{\Gamma \cap \Delta, \beta, D \setminus \Gamma} z_{\beta, \Delta}$$

The internal edges behave as in Proposition 4.4.8. Putting these together, we have the following expression.

$$\begin{aligned} S(\tilde{g}_\Gamma, \bar{g}_\Delta) &= x_{D \setminus (\Gamma \cup \Delta), \Gamma \cap \Delta} (\nu x_{\Gamma \setminus (\Gamma \cap \Delta)}^{\text{out}} x_{\Delta \setminus (\Gamma \cap \Delta)}^{\text{in}} z_{\Gamma \setminus (\Gamma \cap \Delta), \tau}^\beta z_{D \setminus \Delta, \beta, D \setminus \Gamma} z_{\Gamma \cap \Delta, \beta, D \setminus \Gamma} z_{\beta, \Delta} \\ &\quad - x_{\Delta \setminus (\Gamma \cap \Delta)}^{\text{out}} x_{\Gamma \setminus (\Gamma \cap \Delta)}^{\text{in}} z_{\Delta \setminus (\Gamma \cap \Delta), \beta, \Gamma} z_\tau) \\ &= x_{D \setminus (\Gamma \cup \Delta), \Gamma \cap \Delta} (\nu \bar{g}_{\Gamma \setminus (\Gamma \cap \Delta)}^{\text{out}} g_{\Delta \setminus (\Gamma \cap \Delta)}^{\text{in}} z_{\beta, \Gamma \cap \Delta} z_{D \setminus \Delta, \beta, D \setminus \Gamma} z_{\Gamma \cap \Delta, \beta, D \setminus \Gamma} \\ &\quad - x_{\Delta \setminus (\Gamma \cap \Delta)}^{\text{out}} x_{\Gamma \setminus (\Gamma \cap \Delta)}^{\text{in}} z_{\Delta \setminus (\Gamma \cap \Delta), \beta, \Gamma} z_\tau) \end{aligned}$$

Case 8: The computation for the boundary edges is as follows. The greatest common divisor of leading terms is $z_{\Delta, \beta, \Gamma} z_{\Delta \setminus (\Gamma \cap \Delta), \beta, D \setminus \Gamma}$.

$$S(z_{\beta, \Gamma} z_{D \setminus \Gamma, \tau}^\beta - z_\tau, z_{\Delta, \tau}^\beta - z_{\beta, \Delta}) = z_{\Gamma \cap \Delta, \beta, D \setminus \Gamma} z_\tau - z_{D \setminus \Delta, \beta, \Gamma} z_{D \setminus (\Gamma \cup \Delta), \tau}^\beta z_{\Delta \setminus (\Gamma \cap \Delta), \beta, \Gamma} z_{\beta, \Delta}$$

Combining with the appropriate computation for internal edges, we have the following expression.

$$\begin{aligned} S(\tilde{g}_\Gamma, \bar{g}_\Delta) &= x_{\Gamma \setminus (\Gamma \cap \Delta), \Delta \setminus (\Gamma \cap \Delta)} (\nu x_{D \setminus (\Gamma \cup \Delta), \Gamma \cup \Delta} x_{D \setminus (\Gamma \cap \Delta), \Gamma \cap \Delta} z_{D \setminus \Delta, \beta, \Gamma} z_{D \setminus (\Gamma \cup \Delta), \tau}^\beta z_{\Delta \setminus (\Gamma \cap \Delta), \beta, \Gamma} z_{\beta, \Delta} \\ &\quad - x_{\Gamma \cup \Delta, D \setminus (\Gamma \cup \Delta)} x_{\Gamma \cap \Delta, D \setminus (\Gamma \cap \Delta)} z_{\Gamma \cap \Delta, \beta, D \setminus \Gamma} z_\tau) \\ &= x_{\Gamma \setminus (\Gamma \cap \Delta), \Delta \setminus (\Gamma \cap \Delta)} (\nu n_{\Gamma \cup \Delta}^{\text{in}} g_{\Gamma \cap \Delta}^{\text{in}} z_{\Gamma \cap \Delta, \beta, \Delta \setminus (\Gamma \cap \Delta)} z_{\Gamma \setminus (\Gamma \cap \Delta), \beta, \Gamma} z_{\Delta \setminus (\Gamma \cap \Delta), \beta, \Gamma} z_{D \setminus (\Gamma \cup \Delta), \tau}^\beta \\ &\quad - x_{\Gamma \cup \Delta}^{\text{out}} x_{\Gamma \cap \Delta}^{\text{out}} z_{\Gamma \cap \Delta, \beta, D \setminus \Gamma} z_\tau) \end{aligned}$$

Case 9: The computation for the boundary edges is as follows. The greatest common divisor of leading terms is $z_{\beta, D \setminus (\Gamma \cap \Delta)} z_{\Gamma, \beta, \Gamma \cap \Delta}$.

$$S(z_{\beta, D \setminus \Gamma} z_{\Gamma, \tau}^\beta - z_\tau, z_{\beta, \Delta} - z_{\Delta, \tau}^\beta) = z_{D \setminus \Gamma, \beta, \Gamma \cap \Delta} z_\tau - z_{\beta, D \setminus (\Gamma \cup \Delta)} z_{\Gamma, \beta, D \setminus (\Gamma \cap \Delta)} z_{\Delta, \tau}^\beta$$

Combining with the appropriate computation for internal edges, we have the following expression.

$$\begin{aligned}
S(\tilde{g}_\Gamma, \bar{g}_\Delta) &= x_{\Delta \setminus (\Gamma \cap \Delta), \Gamma \setminus (\Gamma \cap \Delta)} (\nu x_{\Gamma \cup \Delta, D \setminus (\Gamma \cup \Delta)} x_{\Gamma \cap \Delta, D \setminus (\Gamma \cap \Delta)} z_{\beta, D \setminus (\Gamma \cup \Delta)} z_{\Gamma, \beta, D \setminus (\Gamma \cap \Delta)} z_{\Delta, \tau}^\beta \\
&\quad - x_{D \setminus (\Gamma \cup \Delta), \Gamma \cup \Delta} x_{D \setminus (\Gamma \cap \Delta), \Gamma \cap \Delta} z_{D \setminus \Gamma, \beta, \Gamma \cap \Delta} z_\tau) \\
&= x_{\Delta \setminus (\Gamma \cap \Delta), \Gamma \setminus (\Gamma \cap \Delta)} (\nu n_{\Gamma \cup \Delta}^{\text{out}} n_{\Gamma \cap \Delta}^{\text{out}} z_{\beta, D \setminus (\Gamma \cup \Delta)} z_{\Gamma \setminus (\Gamma \cap \Delta), \beta, \Gamma \setminus (\Gamma \cap \Delta)} z_{\Gamma \setminus (\Gamma \cap \Delta), \beta, \Delta \setminus (\Gamma \cap \Delta)} z_{\Delta, \beta, \Gamma \cap \Delta} \\
&\quad - x_{\Gamma \cup \Delta}^{\text{in}} x_{\Gamma \cap \Delta}^{\text{in}} z_{D \setminus \Gamma, \beta, \Gamma \cap \Delta} z_\tau) \quad \square
\end{aligned}$$

In cases 1 and 2 of Proposition 4.5.9, we may reduce the results of the S-polynomials by generators that are already in our working basis.

Corollary 4.5.10. *Let Γ and Δ be subsets of D .*

1. *If Γ is out-led, $z_{\Gamma, \tau} \neq 1$, and $\Gamma \cup \Delta$ is in-led, then*

$$S(\tilde{g}_\Gamma, g_\Delta) \xrightarrow{\bar{g}_{\Gamma \cup \Delta}, \nu z_\beta - z_\tau, z_\tau g_{\Gamma \cap \Delta}} 0.$$

If instead $\Gamma \cup \Delta$ is out-led, then

$$S(\tilde{g}_\Gamma, g_\Delta) \xrightarrow{\tilde{g}_{\Gamma \cup \Delta}, z_\tau(z_\tau^i - z_\beta^i), z_\tau g_{\Gamma \cap \Delta}} 0.$$

2. *If Γ is in-led, $z_{\Gamma, \tau} \neq 1$, and $z_{\beta, \Gamma} \neq 1$, then*

$$S(\tilde{g}_\Gamma, g_\Delta) \xrightarrow{\tilde{g}_\Gamma, g_\Delta} 0.$$

Proof. Case 1: If $\Gamma \cup \Delta$ is in-led, then the leading term of $\bar{g}_{\Gamma \cup \Delta}$ divides the leading term of the S-polynomial computed in Proposition 4.5.9. Reduction by $\bar{g}_{\Gamma \cup \Delta}$ leaves

$$S(\tilde{g}_\Gamma, g_\Delta) \xrightarrow{\bar{g}_{\Gamma \cup \Delta}} x_{\Gamma \setminus (\Gamma \cap \Delta), \Delta \setminus (\Gamma \cap \Delta)} x_{\Gamma \cup \Delta}^{\text{out}} z_{\Delta \setminus (\Gamma \cap \Delta), \tau} (\nu g_{\Gamma \cap \Delta}^{\text{in}} z_\beta - g_{\Gamma \cap \Delta}^{\text{out}} z_\tau)$$

Reduce by $\nu z_\beta - z_\tau$ to obtain a multiple of $z_\tau g_{\Gamma \cap \Delta}$, which is already in our basis.

If $\Gamma \cup \Delta$ is out-led, then the leading term of $\tilde{g}_{\Gamma \cup \Delta}$ will be $\bar{g}_{\Gamma \cup \Delta}^{\text{in}} z_{D \setminus (\Gamma \cup \Delta), \tau}^\beta$, which divides the leading term of $S(\tilde{g}_\Gamma, g_\Delta)$. Reducing by $\tilde{g}_{\Gamma \cup \Delta}$ yields

$$S(\tilde{g}_\Gamma, g_\Delta) \xrightarrow{\tilde{g}_{\Gamma \cup \Delta}} z_\tau x_{\Gamma \setminus (\Gamma \cap \Delta), \Delta \setminus (\Gamma \cap \Delta)} x_{\Gamma \cup \Delta}^{\text{out}} (g_{\Gamma \cap \Delta}^{\text{out}} z_{\Delta \setminus (\Gamma \cap \Delta), \tau} - g_{\Gamma \cap \Delta}^{\text{in}} z_{\Delta \setminus (\Gamma \cap \Delta), \tau}^\beta)$$

Reducing by $z_\tau(z_\tau^i - z_\beta^i)$ produces a multiple of $z_\tau g_{\Gamma \cap \Delta}$.

Case 2: Since Γ is assumed to be in-led, the leading term of \tilde{g}_Γ is a product of outgoing edges from Γ . It is related to $\tilde{g}_{\Gamma \setminus (\Gamma \cap \Delta)}^{\text{out}}$, which appears in the S-polynomial by

$$\tilde{g}_\Gamma^{\text{out}} z_{\beta, \Gamma \cap \Delta} = \tilde{g}_{\Gamma \setminus (\Gamma \cap \Delta)}^{\text{out}} x_{\Gamma \cap \Delta, D \setminus (\Gamma \cup \Delta)} z_{\Gamma \cap \Delta, \tau}^\beta.$$

A small rearrangement of the expression in Case 2 of Proposition 4.5.9 shows that the leading term of \tilde{g}_Γ divides $S(\tilde{g}_\Gamma, g_\Delta)$. Reducing by \tilde{g}_Γ produces

$$S(\tilde{g}_\Gamma, g_\Delta) \xrightarrow{\tilde{g}_\Gamma} z_\tau x_{\Delta \setminus (\Gamma \cap \Delta), \Gamma \cap \Delta} x_{D \setminus \Gamma, \Gamma \setminus (\Gamma \cap \Delta)} g_\Delta,$$

which reduces to zero by $z_\tau g_\Delta$. \square

The S-polynomials in cases 3–5 of Proposition 4.5.9 are of the form in Proposition 4.2.5 that reduces by its constituent parts regardless of term order. We have $z_\tau \bar{n}_\Gamma$ in the working basis whenever the corresponding \tilde{g}_Γ is in the working basis, so we may always reduce to zero the expressions that come out of cases 3–5. Because of term order, the S-polynomials in cases 6–9 do not reduce via the relations we currently have available. We postpone these cases until round 3.

At the end of round 2, our working basis remains the same as \mathcal{G}'_1 . Specifically, we have

$$\mathcal{G}_2 = (\nu g_\Gamma, z_\tau g_\Gamma, \nu \bar{g}_\Gamma, z_\tau \bar{g}_\Gamma, \tilde{g}_\Gamma, z_\tau \bar{n}_\Gamma, \nu z_\tau^j - \nu z_\beta^j, z_\tau (z_\tau^j - z_\beta^j), \nu z_\tau - z_\tau, \nu z_\beta - z_\tau),$$

where $1 \leq j \leq b-1$, $\nu \bar{g}_\Gamma$ and $z_\tau \bar{g}_\Gamma$ occur only when $z_{\Gamma, \tau} \neq 1$, and \tilde{g}_Γ and $z_\tau \bar{n}_\Gamma$ occur only when Γ is out-led and $z_{\Gamma, \tau} \neq 1$ or Γ is in-led and $z_{\Gamma, \tau} \neq 1, z_{\beta, \Gamma} \neq 1$. We have also carried forward the following two types of S-polynomials: $S(\nu \bar{g}_\Gamma, \nu \bar{g}_\Delta)$ when Γ is in-led and Δ is out-led; $S(\nu \bar{g}_\Gamma, \tilde{g}_\Delta)$.

4.6 Buchberger's algorithm: Round 3

Having thoroughly analyzed the interactions among the types of relations in our working basis \mathcal{G}_2 in round 2, we now pause to re-evaluate. If we halted the algorithm at this point, four types of generator would survive to be included in the basis for $(\mathcal{Q}'_I(D_\sigma) + \mathcal{N}'_I(D_\sigma) + \mathcal{Z}) \cap (z_\tau)$; namely, $z_\tau (z_\tau^j - z_\beta^j)$, $z_\tau g_\Gamma$, $z_\tau \bar{g}_\Gamma$, and $z_\tau \bar{n}_\Gamma$. The working basis \mathcal{G}_2 only contained $z_\tau \bar{n}_\Gamma$ for certain Γ , but we observe now that these restrictions are unnecessary. If $z_{\Gamma, \tau} = 1$, then $z_{\Gamma, \beta, D \setminus \Gamma} = 1$ and $z_{D \setminus \Gamma, \beta, \Gamma} = z_{\beta, \Gamma}$, so

$$\bar{n}_\Gamma = x_{\Gamma, D \setminus \Gamma} - x_{D \setminus \Gamma, \Gamma} z_{\beta, \Gamma} = \bar{g}_\Gamma.$$

In other words, we may as well say that \mathcal{G}_2 includes $z_\tau \bar{n}_\Gamma$ for all subsets Γ . Now, dividing by z_τ the elements of \mathcal{G}_2 that do not contain ν , we would obtain a basis for the quotient $(\mathcal{Q}'_I(D_\sigma) + \mathcal{N}'_I(D_\sigma) + \mathcal{Z}) : (z_\tau)$ consisting of $z_\tau^j - z_\beta^j$, g_Γ , \bar{g}_Γ , and \bar{n}_Γ . The generators $z_\tau^j - z_\beta^j$ are the standard generating set for \mathcal{Z} . The subset relations g_Γ generate $\mathcal{Q}'_I(D_\sigma)$ or $\mathcal{Q}'_I(D_{\hat{\sigma}})$, since local relations are the same in D_σ and $D_{\hat{\sigma}}$. Modulo the closure relations, the generators \bar{g}_Γ are equivalent to the generators g_Γ and the generators \bar{n}_Γ are the standard generating set for $\mathcal{N}'_I(D_{\hat{\sigma}})$. Therefore, if we could stop the algorithm at this point, we would prove Theorem 4.1.1.

Table 4.3: S-polynomials Round 2, $\mathcal{G}_1 \setminus \mathcal{G}_0$ with \mathcal{G}_0

$S(-, -)$	Result	Prop.	Action
$S(\nu\bar{g}_\Gamma, \nu g_\Delta)$	0	Prop. 4.2.4, 4.5.6	none
$S(\nu\bar{g}_\Gamma, \nu z_\tau^j - \nu z_\beta^j)$	0	Prop. 4.2.3 and 4.2.4	none
$S(\nu\bar{g}_\Gamma, \nu z_\tau - z_\tau)$	$z_\tau \bar{g}_\Gamma$	Prop. 4.4.3	in \mathcal{G}_2
$S(z_\tau g_\Gamma, \nu g_\Delta)$	0	Prop. 4.2.4; round 1	none
$S(z_\tau g_\Gamma, \nu z_\tau^j - \nu z_\beta^j)$	0	Prop. 4.2.4; round 1	none
$S(z_\tau g_\Gamma, \nu z_\tau - z_\tau)$	0	Prop. 4.4.3	none
$S(\tilde{g}_\Gamma, \nu g_\Delta)$	0	Prop. 4.5.7, Cor. 4.5.10	none
$S(\tilde{g}_\Gamma, \nu z_\tau^j - \nu z_\beta^j)$	0	Prop. 4.5.7	none
$S(\tilde{g}_\Gamma, \nu z_\tau - z_\tau)$	0	Prop. 4.4.3	none
$S(\nu z_\beta - z_\tau, \nu g_\Gamma)$	$z_\tau g_\Gamma$	Prop. 4.5.1	in \mathcal{G}_2
$S(\nu z_\beta - z_\tau, \nu z_\tau^j - \nu z_\beta^j)$	$z_\tau (z_\tau^j - z_\beta^j)$	Prop. 4.5.1	in \mathcal{G}_2
$S(\nu z_\beta - z_\tau, \nu z_\tau - z_\tau)$	0	Prop. 4.5.1	none

Table 4.4: S-polynomials Round 2, within $\mathcal{G}_1 \setminus \mathcal{G}_0$

$S(-, -)$	Result	Prop.	Action
$S(\nu\bar{g}_\Gamma, \nu\bar{g}_\Delta)$	*	Prop.4.2.4; 4.5.6	carry
$S(z_\tau g_\Gamma, z_\tau g_\Delta)$	0	Prop. 4.2.4; round 1	none
$S(\tilde{g}_\Gamma, \tilde{g}_\Delta)$	0	Prop. 4.5.9; 4.2.5	none
$S(\nu\bar{g}_\Gamma, z_\tau g_\Delta)$	0	Prop. 4.2.4, Cor. 4.5.6	none
$S(\nu\bar{g}_\Gamma, \tilde{g}_\Delta)$	*	Prop. 4.5.7; 4.5.9	carry
$S(\nu\bar{g}_\Gamma, \nu z_\beta - z_\tau)$	$z_\tau \bar{g}_\Gamma$ or \tilde{g}_Γ or 0	Prop. 4.5.1, 4.5.3	in \mathcal{G}_2
$S(\tilde{g}_\Gamma, z_\tau g_\Delta)$	0	Prop. 4.5.8, 4.5.10	none
$S(z_\tau g_\Gamma, \nu z_\beta - z_\tau)$	0	Prop. 4.5.1	none
$S(\tilde{g}_\Gamma, \nu z_\beta - z_\tau)$	$z_\tau \bar{n}_\Gamma$	Cor. 4.5.2	in \mathcal{G}_2

However, we still must check that any remaining S-polynomials among the generators in \mathcal{G}_2 either reduce to zero or at least fail to produce any new generators that we would have to add to a generating set for the intersection. Fortunately, all of the remaining calculations follow from the work we have already done. To organize the rest of the argument, we think of the generators in \mathcal{G}_2 as falling into three types:

- 2ν -generators, in which both terms are divisible by ν ;
- 1ν -generators, in which only the leading term is divisible by ν ; and
- 0ν -generators, in which neither term is divisible by ν .

The 0ν -generators are all divisible by z_τ and are the only generators that survive to be included in the basis for the intersection of our original ideals. Organized in this way, our current working basis is the following.

2ν	1ν	0ν
νg_Γ	$\nu z_\tau - z_\tau$	$z_\tau g_\Gamma$
$\nu \bar{g}_\Gamma$	$\nu z_\beta - z_\tau$	$z_\tau \bar{g}_\Gamma$
$\nu z_\tau^i - \nu z_\beta^i$	\tilde{g}_Γ	$z_\tau \bar{n}_\Gamma$
		$z_\tau(z_\tau^i - z_\beta^i)$

We have already computed all S-polynomials among the 2ν -generators and have carried forward only $\nu S(\bar{g}_\Gamma, \bar{g}_\Delta)$ when Γ is in-led and Δ is out-led, which is expressed in terms of $\bar{n}_{\Gamma \cup \Delta}$ and $\bar{g}_{\Gamma \cap \Delta}$ in Proposition 4.5.6. We have also already computed all S-polynomials among the 1ν -generators. The results are all recorded in Tables 4.3 and 4.4 and all reduce by generators in \mathcal{G}_2 . We have also computed all S-polynomials between 2ν - and 1ν -generators, with results recorded in Tables 4.1, 4.3, and 4.4. One of these computations, $S(\nu \bar{g}_\Gamma, \tilde{g}_\Delta)$ was carried forward. It has only its leading term divisible by ν .

As mentioned at the beginning of Section 4.4.1, the steps of Buchberger's algorithm that do not involve ν can be regarded as a parallel computation of a Gröbner basis for $(\mathcal{Q}'_I(D_\sigma) + \mathcal{N}'_I(D_\sigma) + \mathcal{Z}) \cap (z_\tau)$. Since we have already determined that the existing 0ν -generators are a basis for $\mathcal{Q}'_I(D_{\hat{\sigma}}) + \mathcal{N}'_I(D_{\hat{\sigma}}) + \mathcal{Z}$, as desired, we know that any further S-polynomials among the 0ν -generators will just produce more redundant generators for $\mathcal{Q}'_I(D_{\hat{\sigma}}) + \mathcal{N}'_I(D_{\hat{\sigma}}) + \mathcal{Z}$. Since we do not actually need to end up with a Gröbner basis for the ideal quotient, there is no need to compute further S-polynomials among 0ν -generators.

For S-polynomials between 0ν - and 2ν -generators, we may always use Proposition 4.2.4 to move a factor of νz_τ to the outside of the computation. In most cases, this leaves a multiple of an S-polynomial we have already computed. The only exception is S-polynomials between 2ν -generators

and \bar{n}_Γ . The necessary computations are very similar to those in Proposition 4.5.6, but we record the results in Proposition 4.6.2.

Finally, we have also already addressed S-polynomials between the 1ν - and 0ν -generators. Propositions 4.4.3 and 4.5.1 showed that the result of $S(\nu z_\tau - z_\tau, -)$ and $S(\nu z_\beta - z_\tau, -)$ applied to any 0ν -generator always reduces to zero. Proposition 4.5.8 shows that $S(\tilde{g}_\Gamma, z_\tau f) = z_\tau S(\tilde{g}_\Gamma, f)$ for any f that is a sum of two monomials. We have already computed $S(\tilde{g}_\Gamma, f)$ for every f such that $z_\tau f \in \mathcal{G}_2$ except $f = \bar{n}_\Gamma$. We will compute $S(\tilde{g}_\Gamma, \bar{n}_\Delta)$ in Proposition 4.6.3. The results are very similar to those of Proposition 4.5.9.

Aside from the S-polynomials involving \bar{n}_Γ , the only possible remaining issue is the S-polynomials that we carried forward from round 2. In their current forms, they do not survive to the basis for the intersection of our ideals: $S(\nu \bar{g}_\Gamma, \nu \bar{g}_\Delta)$ is a 2ν -generator and $S(\tilde{g}_\Gamma, \nu \bar{g}_\Delta)$ is a 1ν -generator. New 0ν -generators can be created from 2ν -generators by double applications of S-polynomials with 1ν -generators, while new 0ν -generators can be created from 1ν -generators by single applications of S-polynomials with 1ν -generators. The leading terms for the S-polynomials we have carried forward are not divisible by z_τ^i for any i , so we know that applications of $S(\nu z_\tau - z_\tau, -)$ will produce expressions that are already reducible in our existing basis. We know from Proposition 4.5.1 that $S(\nu z_\beta - z_\tau, -)$ removes ν and factors of z_β^i from leading terms. Applied twice, it removes factors of z_β^i that divide both terms of a two-term polynomial, removes ν from both terms, and multiplies the polynomial by z_τ . The S-polynomials we have carried forward are expressed in terms of subset relations and non-local relations for unions, intersections, and complements of the subsets Γ and Δ that were put into them. Non-local relations do not have z_β^i that divide both of their terms. If a factor of z_β^i divides both terms of a subset relation, then removing it produces a multiple of the non-local relation associated to the same subset. Therefore, applying $S(\nu z_\beta - z_\tau, -)$ to the S-polynomials we have carried forward will produce expressions in terms of non-local relations and their multiples. These will be reducible in \mathcal{G}_2 . Finally, we might apply \tilde{g}_Γ to one of the S-polynomials that we have carried forward. Applications of $S(\tilde{g}_\Gamma, -)$ to other subset relations also produce expressions in terms of non-local relations and subset relations associated to unions, intersections, and complements of the input subsets. At worst, they remove factors of z_β^i just as $S(\nu z_\beta - z_\tau, -)$ does. Either way, the result will be an expression in terms of non-local relations that can be reduced within \mathcal{G}_2 .

4.6.1 S-polynomials with \bar{n}_Γ

Recall that $\bar{n}_\Gamma = \bar{g}_\Gamma$ if $z_{\Gamma, \tau} = 1$ or $z_{\beta, \Gamma} = 1$. We will ignore this situation, since we have already completed all the necessary S-polynomial calculations with \bar{g}_Γ . Assuming then that $z_{\Gamma, \tau} \neq 1$ and

$z_{\beta, \Gamma} \neq 1$, we still have that \bar{g}_Γ is a multiple of \bar{n}_Γ :

$$\bar{g}_\Gamma = z_{\Gamma, \beta, \Gamma} \bar{n}_\Gamma.$$

The following proposition allows us to compute S-polynomials between \bar{n}_Γ and generators in which no term is divisible by ν by comparing them with S-polynomials where \bar{g}_Γ is in place of \bar{n}_Γ .

Proposition 4.6.1. *Let $f, a \in \mathbb{Q}[\underline{x}']$ and $g \in \mathbb{Q}[\underline{x}', \nu]$ with $f = \text{LT}(f) + f'$ and $g = \text{LT}(g) + g'$, where a, f' , and g' are monomials. Then*

$$S(af, g) = \frac{a}{\gcd(a, \text{LT}(g))} S(f, g) \quad (4.25)$$

Proof. Compute as follows.

$$\begin{aligned} S(af, g) &= \frac{a \text{LT}(f) \text{LT}(g)}{\gcd(a, \text{LT}(g)) \gcd(f, g)} \cdot \frac{1}{a \text{LT}(f)} (af') \\ &\quad - \frac{a \text{LT}(f) \text{LT}(g)}{\gcd(a, \text{LT}(g)) \gcd(f, g)} \cdot \frac{1}{\text{LT}(g)} (g') \\ &= \frac{a}{\gcd(a, \text{LT}(g))} \left(\frac{\text{LT}(f) \text{LT}(g)}{\gcd(f, g)} \cdot \frac{1}{\text{LT}(f)} (f') - \frac{\text{LT}(f) \text{LT}(g)}{\gcd(f, g)} \frac{1}{\text{LT}(g)} (g') \right) \\ &= \frac{a}{\gcd(a, \text{LT}(g))} S(f, g) \quad \square \end{aligned}$$

To apply Proposition 4.6.1, we re-examine the computations from Propositions 4.5.6 and Cases (6)-(9) of 4.5.9 to see how the appropriate factor of $\frac{a}{\gcd(a, \text{LT}(g))}$ can be removed. Notice that there is no need to reconsider leading terms: dividing \bar{g}_Γ by a factor cannot change its term order. Since these computations are so similar to those in Propositions 4.5.6 and 4.5.9, we omit most of the details.

Proposition 4.6.2. *Let Γ and Δ be subsets of D .*

1. *If Γ is in-led, then*

$$S(\bar{n}_\Gamma, g_\Delta) \xrightarrow{z_\tau^i - z_\beta^i} x_{\Gamma \setminus (\Gamma \cap \Delta), \Delta \setminus (\Gamma \cap \Delta)} z_{\Gamma, \beta, \Delta \setminus (\Gamma \cap \Delta)} z_{\Delta \setminus (\Gamma \cap \Delta), \beta, \Gamma \cup \Delta} (\bar{n}_{\Gamma \cup \Delta}^{\text{out}} g_{\Gamma \cap \Delta}^{\text{out}} - \bar{n}_{\Gamma \cup \Delta}^{\text{in}} g_{\Gamma \cap \Delta}^{\text{in}}).$$

2. *If Γ is out-led, then*

$$\begin{aligned} S(\bar{n}_\Gamma, g_\Delta) &\xrightarrow{z_\tau^i - z_\beta^i} x_{\Gamma \cap \Delta, D \setminus (\Gamma \cup \Delta)} z_{D \setminus \Gamma, \beta, \Gamma \cap \Delta} z_{\Gamma \cap \Delta, \beta, \Gamma \cap \Delta} z_{\Gamma \cap \Delta, \beta, D \setminus \Gamma} \\ &\quad \cdot \left(\bar{n}_{\Gamma \setminus (\Gamma \cap \Delta)}^{\text{in}} g_{\Delta \setminus (\Gamma \cap \Delta)}^{\text{out}} - g_{\Delta \setminus (\Gamma \cap \Delta)}^{\text{in}} \bar{n}_{\Gamma \setminus (\Gamma \cap \Delta)}^{\text{out}} \right). \end{aligned}$$

3. *If Γ and Δ are both in-led, then*

$$S(\bar{n}_\Gamma, \bar{g}_\Delta) = x_{\Gamma \cap \Delta, D \setminus (\Gamma \cup \Delta)} z_{\Gamma \cap \Delta, \beta, \Gamma \cap \Delta} z_{D \setminus \Gamma, \beta, \Gamma \cap \Delta} \left(\bar{g}_{\Delta \setminus (\Gamma \cap \Delta)}^{\text{in}} \bar{n}_{\Gamma \setminus (\Gamma \cap \Delta)}^{\text{out}} - \bar{n}_{\Gamma \setminus (\Gamma \cap \Delta)}^{\text{in}} \bar{g}_{\Delta \setminus (\Gamma \cap \Delta)}^{\text{out}} \right).$$

4. If Γ and Δ are both out-led, then

$$S(\bar{n}_\Gamma, \bar{g}_\Delta) = x_{D \setminus (\Gamma \cup \Delta), \Gamma \cap \Delta} z_{\Gamma \cap \Delta, \beta, \Gamma \cap \Delta} z_{\Gamma \cap \Delta, \beta, D \setminus \Gamma} \left(\bar{g}_{\Delta \setminus (\Gamma \cap \Delta)}^{\text{in}} \bar{n}_{\Gamma \setminus (\Gamma \cap \Delta)}^{\text{out}} - \bar{n}_{\Gamma \setminus (\Gamma \cap \Delta)}^{\text{in}} \bar{g}_{\Delta \setminus (\Gamma \cap \Delta)}^{\text{out}} \right).$$

5. If Γ is in-led and Δ is out-led, then

$$S(\bar{n}_\Gamma, \bar{g}_\Delta) = x_{\Gamma \setminus (\Gamma \cap \Delta), \Delta \setminus (\Gamma \cap \Delta)} z_{\Gamma \setminus (\Gamma \cap \Delta), \beta, \Delta \setminus (\Gamma \cap \Delta)} z_{\Delta, \beta, \Delta \setminus (\Gamma \cap \Delta)} (\bar{n}_{\Gamma \cup \Delta}^{\text{out}} \bar{g}_{\Gamma \cap \Delta}^{\text{out}} - \bar{n}_{\Gamma \cup \Delta}^{\text{in}} \bar{g}_{\Gamma \cap \Delta}^{\text{in}}).$$

Proof. Case 1: By Proposition 4.6.1, we have the following relationship between the S-polynomial with \bar{n}_Γ and the one with \bar{g}_Γ .

$$\begin{aligned} S(\bar{g}_\Gamma, g_\Delta) &= \frac{z_{\Gamma, \beta, \Gamma}}{\gcd(z_{\Gamma, \beta, \Gamma}, \text{LT}(g_\Delta))} S(\bar{n}_\Gamma, g_\Delta) \\ &= \frac{z_{\Gamma, \beta, \Gamma}}{\gcd(z_{\Gamma, \beta, \Gamma}, x_{\Delta, D \setminus \Delta} z_{\Delta, \tau})} S(\bar{n}_\Gamma, g_\Delta) \\ &= z_{\Gamma, \beta, \Gamma} S(\bar{n}_\Gamma, g_\Delta) \end{aligned}$$

We may factor $z_{\Gamma, \beta, \Gamma}$ out of $z_{\Gamma \cup \Delta, \beta, \Gamma \cup \Delta}$, which occurs in the terms of $\bar{g}_{\Gamma \cup \Delta}$ in the expression for $S(\bar{g}_\Gamma, g_\Delta)$ from Proposition 4.5.6. The result is to replace $\bar{g}_{\Gamma \cup \Delta}$ with $\bar{n}_{\Gamma \cup \Delta}$ and leave

$$\frac{z_{\Gamma \cup \Delta, \beta, \Gamma \cup \Delta}}{z_{\Gamma, \beta, \Gamma}} = z_{\Gamma, \beta, \Delta \setminus (\Gamma \cap \Delta)} z_{\Delta \setminus (\Gamma \cap \Delta), \beta, \Gamma \cup \Delta}$$

on the outside of the expression.

Case 2: As in case 1, we must factor out $z_{\Gamma, \beta, \Gamma}$ from the expression for $S(\bar{g}_\Gamma, g_\Delta)$ found in Proposition 4.5.6. This requires a small amount of rearranging.

$$\begin{aligned} S(\bar{g}_\Gamma, g_\Delta) &= x_{\Gamma \cap \Delta, D \setminus (\Gamma \cup \Delta)} z_{\beta, \Gamma \cap \Delta} z_{\Gamma \cap \Delta, \tau}^\beta \left(\bar{g}_{\Gamma \setminus (\Gamma \cap \Delta)}^{\text{in}} g_{\Delta \setminus (\Gamma \cap \Delta)}^{\text{out}} - g_{\Delta \setminus (\Gamma \cap \Delta)}^{\text{in}} \bar{g}_{\Gamma \setminus (\Gamma \cap \Delta)}^{\text{out}} \right) \\ &= x_{\Gamma \cap \Delta, D \setminus (\Gamma \cup \Delta)} z_{\beta, \Gamma \cap \Delta} z_{\Gamma \cap \Delta, \tau}^\beta z_{\Gamma \setminus (\Gamma \cap \Delta), \beta, \Gamma \setminus (\Gamma \cap \Delta)} \left(\bar{n}_{\Gamma \setminus (\Gamma \cap \Delta)}^{\text{in}} g_{\Delta \setminus (\Gamma \cap \Delta)}^{\text{out}} - g_{\Delta \setminus (\Gamma \cap \Delta)}^{\text{in}} \bar{n}_{\Gamma \setminus (\Gamma \cap \Delta)}^{\text{out}} \right) \\ &= x_{\Gamma \cap \Delta, D \setminus (\Gamma \cup \Delta)} z_{D \setminus \Gamma, \beta, \Gamma \cap \Delta} z_{\Gamma \cap \Delta, \beta, \Gamma \cap \Delta} z_{\Gamma \cap \Delta, \beta, D \setminus \Gamma} z_{\Gamma, \beta, \Gamma} \\ &\quad \cdot \left(\bar{n}_{\Gamma \setminus (\Gamma \cap \Delta)}^{\text{in}} g_{\Delta \setminus (\Gamma \cap \Delta)}^{\text{out}} - g_{\Delta \setminus (\Gamma \cap \Delta)}^{\text{in}} \bar{n}_{\Gamma \setminus (\Gamma \cap \Delta)}^{\text{out}} \right) \end{aligned}$$

The expression for $S(\bar{n}_\Gamma, g_\Delta)$ in the proposition statement follows immediately.

Cases 3 and 4: As in Cases 3 and 4 of Proposition 4.5.6, there are two subcases here, one in which Γ and Δ are both in-led and one in which they are both out-led. The subcases are very similar, so we again choose to detail only the one in which both subsets are out-led. By Proposition 4.6.1, the monomial we need to factor out of $S(\bar{g}_\Gamma, \bar{g}_\Delta)$ is

$$\frac{z_{\Gamma, \beta, \Gamma}}{\gcd(z_{\Gamma, \beta, \Gamma}, x_{\Delta, D \setminus \Delta} z_{\Delta, \tau}^\beta)} = \frac{z_{\Gamma, \beta, \Gamma}}{z_{\Gamma \cap \Delta, \beta, \Gamma}} = z_{\Gamma \setminus (\Gamma \cap \Delta), \beta, \Gamma}.$$

From Proposition 4.5.6, we have

$$\begin{aligned}
S(\bar{g}_\Gamma, \bar{g}_\Delta) &= x_{\Gamma\cap\Delta, D\setminus(\Gamma\cup\Delta)} z_{\beta, \Gamma\cap\Delta} \left(\bar{g}_{\Delta\setminus(\Gamma\cap\Delta)}^{\text{in}} \bar{g}_{\Gamma\setminus(\Gamma\cap\Delta)}^{\text{out}} - \bar{g}_{\Gamma\setminus(\Gamma\cap\Delta)}^{\text{in}} \bar{g}_{\Delta\setminus(\Gamma\cap\Delta)}^{\text{out}} \right) \\
&= x_{\Gamma\cap\Delta, D\setminus(\Gamma\cup\Delta)} z_{\beta, \Gamma\cap\Delta} z_{\Gamma\setminus(\Gamma\cap\Delta), \beta, \Gamma\setminus(\Gamma\cap\Delta)} \left(\bar{g}_{\Delta\setminus(\Gamma\cap\Delta)}^{\text{in}} \bar{n}_{\Gamma\setminus(\Gamma\cap\Delta)}^{\text{out}} - \bar{n}_{\Gamma\setminus(\Gamma\cap\Delta)}^{\text{in}} \bar{g}_{\Delta\setminus(\Gamma\cap\Delta)}^{\text{out}} \right) \\
&= x_{\Gamma\cap\Delta, D\setminus(\Gamma\cup\Delta)} z_{\Gamma\cap\Delta, \beta, \Gamma\cap\Delta} z_{D\setminus\Gamma, \beta, \Gamma\cap\Delta} z_{\Gamma\setminus(\Gamma\cap\Delta), \beta, \Gamma} \\
&\quad \cdot \left(\bar{g}_{\Delta\setminus(\Gamma\cap\Delta)}^{\text{in}} \bar{n}_{\Gamma\setminus(\Gamma\cap\Delta)}^{\text{out}} - \bar{n}_{\Gamma\setminus(\Gamma\cap\Delta)}^{\text{in}} \bar{g}_{\Delta\setminus(\Gamma\cap\Delta)}^{\text{out}} \right)
\end{aligned}$$

The expression for $S(\bar{n}_\Gamma, \bar{g}_\Delta)$ follows immediately.

Case 5: As in Case 3, we need to factor out $z_{\Gamma\setminus(\Gamma\cap\Delta), \beta, \Gamma}$ from $S(\bar{g}_\Gamma, \bar{g}_\Delta)$. From Proposition 4.5.6, we have the following.

$$S(\bar{g}_\Gamma, \bar{g}_\Delta) = x_{\Gamma\setminus(\Gamma\cap\Delta), \Delta\setminus(\Gamma\cap\Delta)} z_{\Gamma\setminus(\Gamma\cap\Delta), \beta, \Gamma\cup\Delta} z_{\Delta, \beta, \Delta\setminus(\Gamma\cap\Delta)} (\bar{n}_{\Gamma\cup\Delta}^{\text{out}} \bar{g}_{\Gamma\cap\Delta}^{\text{out}} - \bar{n}_{\Gamma\cup\Delta}^{\text{in}} \bar{g}_{\Gamma\cap\Delta}^{\text{in}})$$

Factoring out $z_{\Gamma\setminus(\Gamma\cap\Delta), \beta, \Gamma}$ from $z_{\Gamma\setminus(\Gamma\cap\Delta), \beta, \Gamma\cup\Delta}$ leaves exactly the expression in the statement of this proposition. \square

The same arguments that we made following Proposition 4.5.6 apply again to show that Cases 1–4 above reduce via generators in \mathcal{G}_2 . For the expression in Case 5, the same argument as at the beginning of this section shows that even though it does not reduce by generators in \mathcal{G}_2 , it nonetheless cannot produce any new generators for the ideal intersection.

Proposition 4.6.3. *Let Γ and Δ be subsets of D . (Case numbers are parallel to Proposition 4.5.9.)*

6. *If Γ is out-led and Δ is in-led and $z_{\Gamma, \tau} \neq 1, z_{\Delta, \tau} \neq 1$, then*

$$\begin{aligned}
S(\tilde{g}_\Gamma, \bar{n}_\Delta) &= x_{\Gamma\cap\Delta, D\setminus(\Gamma\cup\Delta)} (\nu \bar{g}_{\Delta\setminus(\Gamma\cap\Delta)}^{\text{out}} g_{\Gamma\setminus(\Gamma\cap\Delta)}^{\text{in}} z_{\Gamma\cap\Delta, \beta, \Gamma\cap\Delta} z_{\Gamma\cap\Delta, \beta, D\setminus\Delta} z_{D\setminus\Gamma, \beta, \Gamma\cap\Delta} z_{D\setminus\Gamma, \beta, D\setminus\Delta} \\
&\quad - x_{\Delta\setminus(\Gamma\cap\Delta)}^{\text{in}} x_{\Gamma\setminus(\Gamma\cap\Delta)}^{\text{out}} z_{\Gamma\setminus(\Gamma\cap\Delta), \beta, \Delta\setminus(\Gamma\cap\Delta)} z_\tau).
\end{aligned}$$

7. *If Γ is in-led and Δ is out-led and $z_{\Gamma, \tau} \neq 1, z_{\beta, \Gamma} \neq 1, z_{\Delta, \tau} \neq 1$, then*

$$\begin{aligned}
S(\tilde{g}_\Gamma, \bar{n}_\Delta) &= x_{D\setminus(\Gamma\cup\Delta), \Gamma\cap\Delta} (\nu \bar{g}_{\Gamma\setminus(\Gamma\cap\Delta)}^{\text{out}} g_{\Delta\setminus(\Gamma\cap\Delta)}^{\text{in}} z_{\Gamma\cap\Delta, \beta, \Gamma\cap\Delta} z_{D\setminus\Delta, \beta, \Gamma\cap\Delta} z_{D\setminus\Delta, \beta, D\setminus\Gamma} z_{\Gamma\cap\Delta, \beta, D\setminus\Gamma} \\
&\quad - x_{\Delta\setminus(\Gamma\cap\Delta)}^{\text{out}} x_{\Gamma\setminus(\Gamma\cap\Delta)}^{\text{in}} z_{\Delta\setminus(\Gamma\cap\Delta), \beta, \Gamma\setminus(\Gamma\cap\Delta)} z_\tau).
\end{aligned}$$

8. *If Γ and Δ are both out-led and $z_{\Gamma, \tau} \neq 1, z_{\Delta, \tau} \neq 1$, then*

$$\begin{aligned}
S(\tilde{g}_\Gamma, \bar{n}_\Delta) &= x_{\Gamma\setminus(\Gamma\cap\Delta), \Delta\setminus(\Gamma\cap\Delta)} \\
&\quad \cdot (\nu n_{\Gamma\cup\Delta}^{\text{in}} g_{\Gamma\cap\Delta}^{\text{in}} z_{\Gamma\setminus(\Gamma\cap\Delta), \beta, \Gamma} z_{\Delta\setminus(\Gamma\cap\Delta), \beta, \Gamma} z_{D\setminus(\Gamma\cup\Delta), \tau}^\beta - x_{\Gamma\cup\Delta}^{\text{out}} x_{\Gamma\cap\Delta}^{\text{out}} z_{\Gamma\cap\Delta, \beta, D\setminus(\Gamma\cup\Delta)} z_\tau).
\end{aligned}$$

9. If Γ and Δ are both in-led and $z_{\Gamma,\tau} \neq 1, z_{\beta,\Gamma} \neq 1$, and $z_{\Delta,\tau} \neq 1$, then

$$\begin{aligned} S(\tilde{g}_\Gamma, \bar{n}_\Delta) &= x_{\Delta \setminus (\Gamma \cap \Delta), \Gamma \setminus (\Gamma \cap \Delta)} \\ &\cdot (\nu n_{\Gamma \cup \Delta}^{\text{out}} n_{\Gamma \cap \Delta}^{\text{out}} z_{\beta, D \setminus (\Gamma \cup \Delta)} z_{\Gamma \setminus (\Gamma \cap \Delta), \beta, \Gamma \setminus (\Gamma \cap \Delta)} z_{\Gamma \setminus (\Gamma \cap \Delta), \beta, \Delta \setminus (\Gamma \cap \Delta)} z_{\Gamma \cap \Delta, \beta, \Gamma \cap \Delta} \\ &- x_{\Gamma \cup \Delta}^{\text{in}} x_{\Gamma \cap \Delta}^{\text{in}} z_{D \setminus (\Gamma \cup \Delta), \beta, \Gamma \cap \Delta} z_\tau). \end{aligned}$$

Proof. Case 6: By Proposition 4.6.1, we need to find the following factor in an expression for $S(\tilde{g}_\Gamma, \bar{g}_\Delta)$.

$$\begin{aligned} \frac{z_{\Delta, \beta, \Delta}}{\gcd(z_{\Delta, \beta, \Delta}, \text{LT}(\tilde{g}_\Gamma))} &= \frac{z_{\Delta, \beta, \Delta}}{\gcd(z_{\Delta, \beta, \Delta}, z_{\beta, \Gamma} z_{D \setminus \Gamma, \tau}^\beta)} \\ &= \frac{z_{\Delta, \beta, \Delta}}{z_{\Delta \setminus (\Gamma \cap \Delta), \beta, \Delta} z_{\Gamma \cap \Delta, \beta, \Gamma \cap \Delta}} \\ &= z_{\Gamma \cap \Delta, \beta, \Delta \setminus (\Gamma \cap \Delta)} \end{aligned}$$

From Proposition 4.5.9, we have the following expression for $S(\tilde{g}_\Gamma, \bar{g}_\Delta)$.

$$\begin{aligned} S(\tilde{g}_\Gamma, \bar{g}_\Delta) &= x_{\Gamma \cap \Delta, D \setminus (\Gamma \cup \Delta)} (\nu \bar{g}_{\Delta \setminus (\Gamma \cap \Delta)}^{\text{out}} g_{\Gamma \setminus (\Gamma \cap \Delta)}^{\text{in}} z_{\Gamma \cap \Delta, \tau}^\beta z_{D \setminus \Gamma, \beta, \Gamma \cap \Delta} z_{D \setminus \Gamma, \beta, D \setminus \Delta} \\ &- x_{\Delta \setminus (\Gamma \cap \Delta)}^{\text{in}} x_{\Gamma \setminus (\Gamma \cap \Delta)}^{\text{out}} z_{\Gamma, \beta, \Delta \setminus (\Gamma \cap \Delta)} z_\tau) \end{aligned}$$

Factoring $z_{\Gamma \cap \Delta, \beta, \Delta \setminus (\Gamma \cap \Delta)}$ out of $z_{\Gamma \cap \Delta, \tau}^\beta$ in the first term and out of $z_{\Gamma, \beta, \Delta \setminus (\Gamma \cap \Delta)}$ in the second term yields the expression in the statement of this proposition.

Case 7: By Proposition 4.6.1, we need to find the following factor in an expression for $S(\tilde{g}_\Gamma, \bar{n}_\Delta)$.

$$\begin{aligned} \frac{z_{\Delta, \beta, \Delta}}{\gcd(z_{\Delta, \beta, \Delta}, \text{LT}(\tilde{g}_\Gamma))} &= \frac{z_{\Delta, \beta, \Delta}}{\gcd(z_{\Delta, \beta, \Delta}, z_{\beta, D \setminus \Gamma} z_{\Gamma, \tau}^\beta)} \\ &= \frac{z_{\Delta, \beta, \Delta}}{z_{\Delta, \beta, \Delta \setminus (\Gamma \cap \Delta)} z_{\Gamma \cap \Delta, \beta, \Gamma \cap \Delta}} \\ &= z_{\Delta \setminus (\Gamma \cap \Delta), \beta, \Gamma \cap \Delta} \end{aligned}$$

From Proposition 4.5.9, we have the following expression for $S(\tilde{g}_\Gamma, \bar{g}_\Delta)$.

$$\begin{aligned} S(\tilde{g}_\Gamma, \bar{g}_\Delta) &= x_{D \setminus (\Gamma \cup \Delta), \Gamma \cap \Delta} (\nu \bar{g}_{\Gamma \setminus (\Gamma \cap \Delta)}^{\text{out}} g_{\Delta \setminus (\Gamma \cap \Delta)}^{\text{in}} z_{\beta, \Gamma \cap \Delta} z_{D \setminus \Delta, \beta, D \setminus \Gamma} z_{\Gamma \cap \Delta, \beta, D \setminus \Gamma} \\ &- x_{\Delta \setminus (\Gamma \cap \Delta)}^{\text{out}} x_{\Gamma \setminus (\Gamma \cap \Delta)}^{\text{in}} z_{\Delta \setminus (\Gamma \cap \Delta), \beta, \Gamma} z_\tau). \end{aligned}$$

Factoring $z_{\Delta \setminus (\Gamma \cap \Delta), \beta, \Gamma \cap \Delta}$ out of $z_{\beta, \Gamma \cap \Delta}$ in the first term and out of $z_{\Delta \setminus (\Gamma \cap \Delta), \beta, \Gamma}$ in the second term yields the expression in the statement of this proposition.

Case 8: Since Γ is out-led in this case as well, we need to find the same factor of $z_{\Gamma \cap \Delta, \beta, \Delta \setminus (\Gamma \cap \Delta)}$ in an expression for $S(\tilde{g}_\Gamma, \bar{n}_\Delta)$ as in Case 6. Case 8 of Proposition 4.5.9 produces an expression for $S(\tilde{g}_\Gamma, \bar{g}_\Delta)$ in which the first term has a factor of $z_{\Gamma \cap \Delta, \beta, \Delta \setminus (\Gamma \cap \Delta)}$ and the second has a factor of

$z_{\Gamma \cap \Delta, \beta, D \setminus \Gamma}$. Factoring $z_{\Gamma \cap \Delta, \beta, \Delta \setminus (\Gamma \cap \Delta)}$ out of these terms yields the expression in the statement of this proposition.

Case 9: Since Γ is in-led in this case as well, we need to find the same factor of $z_{\Delta \setminus (\Gamma \cap \Delta), \beta, \Gamma \cap \Delta}$ in an expression for $S(\tilde{g}_\Gamma, \bar{n}_\Delta)$ as in Case 7. Case 9 of Proposition 4.5.9 produces an expression for $S(\tilde{g}_\Gamma, \bar{g}_\Delta)$ in which the first term has a factor of $z_{\Delta, \beta, \Gamma \cap \Delta}$ and the second has a factor of $z_{D \setminus \Gamma, \beta, \Gamma \cap \Delta}$. Factoring $z_{\Delta \setminus (\Gamma \cap \Delta), \beta, \Gamma \cap \Delta}$ out of these terms yields the expression in the statement of this proposition. \square

By the same arguments that we made at the beginning of this section about $S(\tilde{g}_\Gamma, \bar{g}_\Delta)$, the expressions in Proposition 4.6.3 do not produce any new generators for the ideal intersection.

Bibliography

- [1] W.W. Adams and P. Loustau. *An introduction to Gröbner bases*. American Mathematical Society, 1994.
- [2] John A. Baldwin and Olga Plamenevskaya. Khovanov homology, open books, and tight contact structures. *Advances in Mathematics*, 224(6):2544–2582, 2010. Preprint arXiv:0808.2336v2.
- [3] Christian Blanchet. Nodal foams and link homology. 2010. Slides from talk, available at <http://www.math.jussieu.fr/blanchet/Slides/zurich.pdf>.
- [4] Bruno Buchberger. *Ein Algorithmus zum Auffinden der Basiselemente des Restklassenringes nach einem nulldimensionalen Polynomideal*. PhD thesis, Leopold-Franzens Universität Innsbruck, Innsbruck, Austria, 1965.
- [5] D.A. Cox, J. Little, D. O’Shea, and M. Sweedler. *Ideals, varieties, and algorithms*. Springer, 1992.
- [6] Nathan M. Dunfield, Sergei Gukov, and Jacob Rasmussen. The superpolynomial for knot homologies. *Experimental Mathematics*, 15(2):129–159, 2006. Preprint arXiv:math/0505662v2.
- [7] D. Eisenbud. *Commutative algebra with a view toward algebraic geometry*. Springer, 1995.
- [8] Ben Elias and Mikhail Khovanov. Diagrammatics for Soergel categories. 2009. Preprint arXiv:0902.4700v1.
- [9] Ben Elias and Daniel Krasner. Rouquier complexes are functorial over braid cobordisms. *Homology, Homotopy and Applications*, 12(2):109–146, 2010. Preprint arXiv:0906.4761v3.
- [10] P. Freyd, D. Yetter, J. Hoste, W.B.R. Lickorish, K. Millett, and A. Ocneanu. A new polynomial invariant of knots and links. *Bulletin of the American Mathematical Society*, 12(2):239–246, 1985.
- [11] Daniel R. Grayson and Michael E. Stillman. Macaulay2, a software system for research in algebraic geometry. available at <http://www.math.uiuc.edu/Macaulay2/>.
- [12] J. Elisenda Grigsby, Matthew Hedden, and Kenneth Baker. Grid diagrams for lens spaces and combinatorial knot Floer homology. *International Mathematics Research Notices*, 2008. Preprint arXiv:0710.0359v2.
- [13] J. Elisenda Grigsby, Daniel Ruberman, and Sašo Strle. Knot concordance and Heegaard Floer homology invariants in branched covers. *Geometry and Topology*, 12:2249–2275, 2008. Preprint arXiv:math/0701460v2.

- [14] J. Elisenda Grigsby and Stephan M. Wehrli. Khovanov homology, sutured Floer homology, and annular links. *Algebraic and Geometric Topology*, 10:2010, 2009. Preprint arXiv:0907.4375.
- [15] Matthew Hedden and Philip Ording. The Ozsváth-Szabó and Rasmussen concordance invariants are not equal. 2005. Preprint arXiv:math/0512348v1.
- [16] V.F.R. Jones. Hecke algebra representations of braid groups and link polynomials. *Annals of Mathematics*, 125:335–388, 1987.
- [17] Christian Kassel. Homology and cohomology of associative algebras: A concise introduction to cyclic homology. *Advanced School on Non-commutative Geometry, ICTP, Trieste*, 2004.
- [18] Mikhail Khovanov. A categorification of the Jones polynomial. *Duke Mathematical Journal*, 101(3):359–426, 2000. Preprint arXiv:math/9908171v2.
- [19] Mikhail Khovanov. A functor-valued invariant of tangles. *Algebraic and Geometric Topology*, 2:665–741, 2002. Preprint arXiv:math/0103190v2.
- [20] Mikhail Khovanov. $\mathfrak{sl}(3)$ link homology. *Algebraic and Geometric Topology*, 4:1045–1081, 2004. Preprint arXiv:math/0304375v2.
- [21] Mikhail Khovanov. Triply-graded link homology and Hochschild homology of Soergel bimodules. *International Journal of Mathematics*, 18(8):869–886, 2007. Preprint arXiv:math/0510265v3.
- [22] Mikhail Khovanov and Lev Rozansky. Matrix factorizations and link homology. *Fundamenta Mathematicae*, 199:1–91, 2008. Preprint arXiv:math/0401268v2.
- [23] Mikhail Khovanov and Lev Rozansky. Matrix factorizations and link homology II. *Geometry and Topology*, 12:1387–1425, 2008. Preprint arXiv:math/0505056v2.
- [24] Mikhail Khovanov and Paul Seidel. Quivers, Floer cohomology, and braid group actions. *Journal of the American Mathematical Society*, 15(1):203–271, 2002. Preprint arXiv:math/0006056v2.
- [25] Mikhail Khovanov and Richard Thomas. Braid cobordisms, triangulated categories, and flag varieties. *Homology, Homotopy and Applications*, 9:19–94, 2007. Preprint arXiv:math/0609335v2.
- [26] Robert Lipshitz, Peter Ozsváth, and Dylan Thurston. Bordered Floer homology and the branched double cover I. 2010. Preprint arXiv:1011.0499v1.
- [27] Paolo Lisca, Peter Ozsváth, András Stipsicz, and Zoltán Szabó. Heegaard Floer invariants of Legendrian knots in contact three-manifolds. 2009. Preprint arXiv:0802.0628v2.
- [28] Marco Mackaay, Marko Stosic, and Pedro Vaz. $\mathfrak{sl}(n)$ link homology using foams and the Kapustin-Li formula. 2007. Preprint arXiv:0708.2228v3.
- [29] Ciprian Manolescu, Peter Ozsváth, Zoltan Szabó, and Dylan Thurston. On combinatorial link Floer homology. *Geometry and Topology*, 11:2339–2412, 2007. Preprint arXiv:math/0610559v3.
- [30] Hitoshi Murakami, Tomotada Ohtsuki, and Shuji Yamada. HOMFLY polynomial via an invariant of colored plane graphs. *L’Enseignement Mathématique*, 44(3-4):325–360, 1998.
- [31] Lenhard Ng. A Legendrian Thurston-Bennequin bound from Khovanov homology. *Algebraic and Geometric Topology*, 5:1637–1653, 2005. Preprint arXiv:math/0508649v3.

- [32] Lenhard Ng, Peter Ozsváth, and Dylan Thurston. Transverse knots distinguished by knot Floer homology. *Journal of Symplectic Geometry*, 6:461–490, 2008. Preprint arXiv:math/0703446v2.
- [33] Peter Ozsváth, Ciprian Manolescu, and Sucharit Sarkar. A combinatorial description of knot Floer homology. *Annals of Mathematics*, 169(2):633–660, 2009. Preprint arXiv:math/0607691v2.
- [34] Peter Ozsváth, András Stipsicz, and Zoltán Szabó. Floer homology and singular knots. *Journal of Topology*, 2(2):380, 2009. Preprint arXiv:0705.2661v3.
- [35] Peter Ozsváth and Zoltán Szabó. Heegaard Floer homologies and contact structures. 2002. Preprint arXiv:math/0210127.
- [36] Peter Ozsváth and Zoltán Szabó. Absolutely graded Floer homologies and intersection forms for four-manifolds with boundary. *Advances in Mathematics*, 173(2):179–261, 2003. Preprint arXiv:math/0110170v2.
- [37] Peter Ozsváth and Zoltán Szabó. Knot Floer homology and the four-ball genus. *Geometry and Topology*, 7:615–639, 2003. Preprint arXiv:math/0301149v4.
- [38] Peter Ozsváth and Zoltán Szabó. Holomorphic disks and knot invariants. *Advances in Mathematics*, 186(1):58–116, 2004. Preprint arXiv:math/0209056v4.
- [39] Peter Ozsváth and Zoltán Szabó. Holomorphic disks and topological invariants for closed three-manifolds. *Annals of Mathematics*, 159(3):1027–1158, 2004. Preprint arXiv:math/0101206.
- [40] Peter Ozsváth and Zoltán Szabó. Knot Floer homology, genus bounds, and mutation. *Topology and its Applications*, 141(1-3):59–85, 2004. Preprint arXiv:math/0303225v2.
- [41] Peter Ozsváth and Zoltán Szabó. On Knot Floer homology and lens space surgeries. 2004. Preprint arXiv:math/0303017v2.
- [42] Peter Ozsváth and Zoltán Szabó. On the Heegaard Floer homology of branched double-covers. *Advances in Mathematics*, 194(1):1–33, 2005. Preprint arXiv:math/0309170v1.
- [43] Peter Ozsváth and Zoltán Szabó. The Dehn surgery characterization of the trefoil and the figure eight knot. 2006. Preprint arXiv:math/0604079.
- [44] Peter Ozsváth and Zoltán Szabó. Holomorphic triangles and invariants for smooth four-manifolds. *Advances in Mathematics*, 202(2):326–400, 2006. Preprint arXiv:math/0110169v2.
- [45] Peter Ozsváth and Zoltán Szabó. A cube of resolutions for knot Floer homology. *Journal of Topology*, 2(4):865, 2009. Preprint arXiv:0705.3852v1.
- [46] Peter Ozsváth, Zoltan Szabó, and Dylan Thurston. Legendrian knots, transverse knots and combinatorial Floer homology. *Geometry and Topology*, 12(2):941–980, 2008. Preprint arXiv:math/0611841v2.
- [47] Jacob Rasmussen. *Floer homology and knot complements*. PhD thesis, Harvard University, 2003. Preprint arXiv:math/0306378v1.
- [48] Jacob Rasmussen. Khovanov homology and the slice genus. *Inventiones Mathematicae*, pages 1–29, 2004. Preprint arXiv:math/0402131.

- [49] Jacob Rasmussen. Some differentials on Khovanov-Rozansky homology. 2006. Preprint arXiv:0607544v2.
- [50] Raphael Rouquier. Categorification of the braid groups. 2004. Preprint arXiv:math/0409593v1.
- [51] Sucharit Sarkar and Jiajun Wang. An algorithm for computing some Heegaard Floer homologies, (formerly titled: A combinatorial description of some Heegaard Floer homologies). *Annals of Mathematics*, 171(2):1213–1236, 2010. Preprint arXiv:math/0607777v4.
- [52] Wolfgang Soergel. The combinatorics of Harish-Chandra bimodules. *J. Reine Angew. Math.*, 429:49–74, 1992.
- [53] Wolfgang Soergel. Gradings on representation categories. *Proceedings of the International Congress of Mathematicians*, Vol. 1, 2, Zürich, 1994.